



Notice is hereby given that the Rainbow Municipal Water District Board of Directors will hold Open Session with the Budget and Finance Committee at 1:00 p.m. Tuesday, May 22, 2018, at the District Office located at 3707 Old Highway 395, Fallbrook, CA 92028. At any time during the session, the Board of Directors Meeting may adjourn to Closed Session to consider litigation or to discuss with legal counsel matters within the attorney client privilege.

## **AGENDA**

**1. CALL TO ORDER**

**2. PLEDGE OF ALLEGIANCE**

**3. BOARD OF DIRECTORS ROLL CALL:**

**Brazier**\_\_\_\_ **Hamilton**\_\_\_\_ **Gasca**\_\_\_\_ **Mack**\_\_\_\_ **Stewart**\_\_\_\_

**BUDGET AND FINANCE COMMITTEE ROLL CALL:**

**Members:** **Harry Stitle** \_\_\_\_ **Randy Ross** \_\_\_\_ **Peter Hensley** \_\_\_\_ **Miguel Gasca** \_\_\_\_  
**Pam Moss**\_\_\_\_

**Alternates:** **Flint Nelson**\_\_\_\_ **Vanessa Martinez**\_\_\_\_

**4. ADDITIONS/DELETIONS/AMENDMENTS TO THE AGENDA (Government Code §54954.2)**

**5. ORAL/WRITTEN COMMUNICATIONS FROM THE PUBLIC  
OPPORTUNITY FOR MEMBERS OF THE PUBLIC TO ADDRESS THE BOARD REGARDING  
ITEMS NOT ON THIS AGENDA (Government Code § 54954.2).**

Under Oral Communications, any person wishing to address the Board on matters not on this agenda should indicate their desire to speak by filling out and submitting a "Speaker's Slip" to the Board Secretary before the meeting begins. *No action will be taken on any oral communications item since such item does not appear on this Agenda, unless the Board of Directors makes a determination that an emergency exists or that the need to take action on the item arose subsequent to posting of the Agenda (Government Code §54954.2). Speaking time shall generally be limited to three minutes, unless a longer period is permitted by the Board President.*

**6. EMPLOYEE RECOGNITIONS**

- A.** Ruben Lopez (10 Years)
- B.** Rene Del Rio (15 Years)

**\*7. APPROVAL OF MINUTES**

- A.** April 24, 2018 - Regular Board Meeting

**8. BOARD OF DIRECTORS' COMMENTS/REPORTS**

Directors' comments are comments by Directors concerning District business, which may be of interest to the Board. This is placed on the agenda to enable individual Board members to convey information to the Board and to the public. There is to be no discussion or action taken by the Board of Directors unless the item is noticed as part of the meeting agenda.

- A.** President's Report (Director Brazier)
- B.** Representative Report (Appointed Representative)
  - 1.** SDCWA
  - 2.** CSDA

(\*) - Asterisk indicates a report is attached.

- 3. LAFCO
- 4. San Luis Rey Watershed Council
- 5. Santa Margarita River Watershed Watermaster Steering Committee
- C. Meeting, Workshop, Committee, Seminar, Etc. Reports by Directors (AB1234)
- D. Directors Comments
- E. Legal Counsel Comments
  - 1. Attorney Report: Endangered Species and Water Projects (501668-0002)

**\*9. COMMITTEE REPORTS (Approved Minutes have been attached for reference only.)**

- A. Budget and Finance Committee
  - 1. April 10, 2018 Minutes
- B. Communications Committee
  - 1. April 5, 2018 Minutes
- C. Engineering and Operations Committee
  - 1. April 4, 2018 Minutes

**PRESENTATION**

**10. PIPE RELINING PROJECT UPDATE BY SDCWA**

**CONSENT CALENDAR**

- \*11. DISCUSSION AND POSSIBLE ACTION TO APPROVE ORDINANCE NO. 18-12 - AMENDING AND UPDATING ADMINISTRATIVE CODE SECTION 1.02.020 – CONFLICT OF INTEREST**  
*(In reviewing the Administrative Code, it was realized the definition provided for Auditor erroneously referenced standing committees.)*
- \*12. DISCUSSION AND POSSIBLE ACTION TO APPROVE ORDINANCE NO. 18-13 - AMENDING AND UPDATING ADMINISTRATIVE CODE CHAPTER 2.09 – COMMITTEES**  
*(The Communications Committee has voted to recommend the Board approve amending the committee's charter to include customer service.)*

**BOARD INFORMATION ITEMS**

- 13. INITIAL REVIEW OF OPERATING AND CAPITAL IMPROVEMENT BUDGET FOR FISCAL YEAR 2018-2019**
- 14. STAFFING ANALYSIS UPDATE**  
*(The purpose of this information report is to present the Board with an updated staffing analysis for the District. This staffing analysis forecasts the organizational and personnel changes required to maintain a successful workforce plan for the next five fiscal years (FY 2018-2019 to 2023-2024).)*
- 15. STRATEGIC PLAN OBJECTIVES UPDATES**

**BOARD ACTION ITEMS**

- \*16. CONSIDER A PROFESSIONAL SERVICES AGREEMENT WITH KINSEY AND KINSEY INC. FOR IMPLEMENTATION SERVICES RELATED TO THE INFOR CLOUDSUITE FINANCIALS SOFTWARE SYSTEM IN THE AMOUNT OF \$163,800 AND AUTHORIZE THE GENERAL MANAGER TO EXECUTE THE CONTRACT ON THE DISTRICT'S BEHALF**  
*(This agenda item is for approval of a Professional Services Agreement (PSA) with Kinsey and Kinsey Inc. (hereafter Kinsey) for implementation and data conversion services required to deploy the new finance software from Infor Global Solutions that will replace the current system from Acela Springbrook.)*

(\*) - Asterisk indicates a report is attached.

- \*17. **DISCUSSION AND POSSIBLE ACTION TO APPROVE CONTRACT CHANGE ORDER FOR INSPECTION SERVICES FOR THE HORSE CREEK RIDGE DEVELOPMENT**  
*(Hoch Consulting has been assisting the District with inspection services, has proven to be a valuable consultant, and are familiar with the work needed to complete the Horse Creek Ridge development. This item proposes to extend the current contract with Hoch Consulting to finish out the inspection for the Horse Creek Ridge Development.)*
  
- \*18. **DISCUSSION AND POSSIBLE ACTION TO APPROVE AMENDMENT TO SEWER SERVICE AGREEMENT FOR THE PALOMAR NORTH EDUCATION CENTER**  
*(A Sewer Service Agreement was approved by Board action on April 24, 2018 which prohibits discharge before the completion of the Horse Creek Lift Station. D.R. Horton has consented to allowing Palomar to discharge to their temporary lift station, pending District approval, in order to serve the campus until the lift station is completed. This amendment to the sewer service agreement grants approval of Palomar's discharge if they meet additional conditions of approval.)*
  
- \*19. **DISCUSSION AND POSSIBLE ACTION ON REQUEST TO QUITCLAIM EASEMENTS FOR PALA MESA HIGHLANDS DEVELOPMENT TM 5187-1**  
*(The District owns 20 foot wide easements which run through the Western parcels of the Pala Mesa Highlands development for a 12" steel waterline which has been relocated. The District no longer needs easement rights to access and maintain the pipeline. Therefore, the easements can be quitclaimed. Quitclaiming the easements will relinquish rights back to the property owners.)*
  
- \*20. **DISCUSSION AND POSSIBLE ACTION TO APPROVE A CHANGE ORDER FOR REDESIGN SERVICES FOR THE RAINBOW HEIGHTS PUMP STATION REHABILITATION PROJECT**  
*(The Metropolitan Water District (MWD) has an easement across the easterly half of the Rainbow Heights Pump Station property. In January 2018, Rainbow staff was notified that the location of the proposed pump station improvements as well as the existing facilities within the easement were unacceptable. This change order will account for the redesign effort to move the pump station improvements outside of the MWD easement.)*
  
- 21. **AUTHORIZATION TO ATTEND UPCOMING MEETINGS / CONFERENCES / SEMINARS**
  
- \*22. **RECEIVE AND FILE INFORMATION AND FINANCIAL ITEMS**
  - A. **General Manager Comments**
    - 1. Meetings, Conferences and Seminar Calendar
  - B. **Operations Comments**
    - 1. Operations Report
  - C. **Engineering Comments**
    - 1. Engineering Report
  - D. **Customer Service and Meters Comments**
    - 1. Customer Service and Meters Report
  - E. **Human Resource & Safety Comments**
    - 1. Human Resources Report
  - F. **Finance Comments**
    - 1. Interim Financial Statement
    - 2. Treasurer Report
    - 3. Credit Card Breakdown
    - 4. Directors' Expense
    - 5. Check Register
    - 6. Water Sales Summary
    - 7. RMWD Sewer Equivalent Dwelling Units (EDU's) Status
  
- 23. **LIST OF SUGGESTED AGENDA ITEMS FOR THE NEXT REGULAR BOARD MEETING**

(\*) - Asterisk indicates a report is attached.

24. ADJOURNMENT - To Tuesday, June 26, 2018 at 1:00 p.m.

**ATTEST TO POSTING:**



Hayden Hamilton  
Secretary of the Board

5-11-18 @ 1:30 p.m.

Date and Time of Posting  
Outside Display Cases

(\*) - Asterisk indicates a report is attached.



**MINUTES OF THE REGULAR BOARD MEETING  
OF THE BOARD OF DIRECTORS OF THE  
RAINBOW MUNICIPAL WATER DISTRICT  
APRIL 24, 2018**

1. **CALL TO ORDER** - The Regular Meeting of the Board of Directors of the Rainbow Municipal Water District on April 24, 2018 was called to order by President Brazier at 1:00 p.m. in the Board Room of the District, 3707 Old Highway 395, Fallbrook, CA 92028. President Brazier presiding.

2. **PLEDGE OF ALLEGIANCE**

3. **ROLL CALL:**

**Present:** Director Brazier, Director Hamilton, Director Mack, Director Gasca

**Also Present:** General Manager Kennedy, Legal Counsel Smith, Executive Assistant Washburn, Administrative Analyst Gray, Associate Engineer Powers, Finance Manager Martinez, Human Resources Manager Harp, Operations Manager Milner, Superintendent Maccarrone, Superintendent Walker, Superintendent Zuniga, Interim Engineering Manager Gerdes.

**Absent:** Director Stewart.

Eight members of the public were present.

4. **ADDITIONS/AMENDMENTS TO THE AGENDA (Government Code §54954.2)**

President Brazier noted the Rainbow Public Facilities Corporation meeting will be conducted between Items #20 and #21.

5. **ORAL/WRITTEN COMMUNICATIONS FROM THE PUBLIC OPPORTUNITY FOR MEMBERS OF THE PUBLIC TO ADDRESS THE BOARD REGARDING ITEMS NOT ON THIS AGENDA (Government Code § 54954.2).**

Paige Bruyn read aloud a statement on behalf of her mother, Mrs. Pearce, a 29-year customer of RMWD, who was evacuated due to the Lilac Fire. She addressed the Board regarding her concerns about a billing issue Mrs. Pearce experienced and how it was addressed by customer service. She provided a copy of her statement and copy of Mrs. Pearce's usage to the Board.

President Brazier said she was distressed to hear about this situation and asked whether it has been escalated beyond customer service.

Mr. Kennedy explained the matter in particular has been resolved. He stated as a result, one of the items the Communications Committee will be talking about is expanding the Board's oversight of customer service by having a customer service component added to the committee's charter. He pointed out staff was constrained by the Administrative Code in what they are allowed to do based on the policies in place to be followed. He said there was some certain rigidity he and Director Hamilton have decided should be looked at with the Communications Committee to

(\*) - Asterisk indicates a report is attached.

***DRAFT***

***DRAFT***

***DRAFT***

determine the right balance between fiduciary duty to all the ratepayers as well as try to be resolution oriented as opposed to process oriented.

President Brazier asked what a customer should do if they are dissatisfied with the results provided by customer service to pursue the matter. Mr. Kennedy explained the proper protocol would be to contact the department manager followed by the General Manager; however, all RMWD staff is bound by the same Administrative Code. He reiterated a review of the Administrative Code would be the appropriate mechanism with input from a committee of ratepayers.

President Brazier suggested there be additional staff retraining on how to deal appropriately with customers. Mr. Kennedy noted there are laws against employees revealing customer information and protecting RMWD's customer's privacy. He agreed the balance needs to be found in these situations; however, in this particular case there is no indication a direct policy was not followed by staff.

Mr. Kennedy apologized to Mrs. Pearce for what took place. He confirmed something will be published in the District's newsletter notifying customers there was a means for granting authorizing for others to get account information and assistance.

Mrs. Pierce noted she was contacted by RMWD staff that her lost check has been found and will be mailed back to her. Mrs. Martinez agreed to follow up on this matter as well as review the variance report on this account to verify if the spike in usage was caused by Lilac Fire activity.

## **6. ACKNOWLEDGEMENTS**

### **A. District Recognition from Employer Support of the Guard and Reserve (ESGR) for Supporting Military Service**

Mr. Kennedy introduced Frank Gardner, Area Chair for the Employer Support of the Guard and Reserve (ESGR).

Mr. Gardner announced he would be giving a presentation of several awards. He thanked the Board of Directors for supporting the Guard and Reserve in allowing their members to go in deployment when called upon.

Mr. Gardner presented Mr. Kennedy with the Seven Seals Award. He educated the Board on the ESGR organization that was established in 1972 as a means of employers recognizing and understanding the importance of supporting reservists while on deployment. He thanked Mr. Kennedy for his support of Reservist Darren Milner.

Mr. Gardner asked Mr. Kennedy to sign a Statement of Support for the Guard and Reserve on behalf of RMWD. He noted by signing the statement, Mr. Kennedy will be recognizing the Guard and Reserve to the strength of our nation and the well-being of our communities. He read aloud the statement and pledge being signed.

Mr. Milner presented staff members with plaques in recognition of his appreciation of their efforts in continuing the work while he is in military training and deployment. Mr. Gardner stated these staff members were being recognized for the sacrifices they make when combining workforces during Mr. Milner's absence.

(\*) - Asterisk indicates a report is attached.



**DRAFT**

**DRAFT**

**DRAFT**

Mr. Gardner presented President Brazier with the Above and Beyond Award on behalf of the Board of Directors. President Brazier stated as a widow of a career soldier and member of the military family, she thanked Mr. Gardner for his service and volunteering in this program.

Mr. Milner presented Mr. Gardner with a Military Tradition Coin on behalf of the his Unit's Engineers and Civil Engineers.

Mr. Gardner encouraged anyone interested in volunteering for the ESGR to contact Mr. Milner.

**B. Commendation Presentation**

Mr. Kennedy presented Harry Stittle with a plaque of the commendation Resolution the Board of Directors approved at their February 27, 2018 meeting.

**C. Anniversary Awards**

**1. Chris Hand (10 Years)**

Mr. Kennedy noted Chris Hand has been a member of the Wastewater Department for ten years making sure things running smoothly. He presented Mr. Hand with a plaque and check in recognition of his tenure.

**2. Cynthia Steward (10 Years)**

Mr. Kennedy noted Cynthia Steward has worked at RMWD as a Customer Service Representative for ten years who does her best to assist customers while meeting their expectations. He presented Mrs. Steward with a plaque and check in recognition of her tenure.

**3. Gloria Dechert (15 Years)**

Mr. Kennedy noted Gloria Dechert has provided administrative support in the many positions she has held during her fifteen years at RMWD. He presented Mrs. Dechert with a plaque and check in recognition of her tenure.

President Brazier stated she is appreciative in the work and the difficulties in the job everyone does.

**\*7. APPROVAL OF MINUTES**

**A. March 27, 2018 - Regular Board Meeting**

***Motion:***

***To approve the minutes as presented.***

***Action: Approve, Moved by Director Hamilton, Seconded by Director Mack***

***Vote: Motion carried by unanimous vote (Summary: Ayes=4).***

***Ayes: Director Brazier, Director Hamilton, Director Mack, Director Gasca.***

(\*) - Asterisk indicates a report is attached.

**\*8. BOARD OF DIRECTORS' COMMENTS/REPORTS**

Directors' comments are comments by Directors concerning District business, which may be of interest to the Board. This is placed on the agenda to enable individual Board members to convey information to the Board and to the public. There is to be no discussion or action taken by the Board of Directors unless the item is noticed as part of the meeting agenda.

**A. President's Report (Director Brazier)**

President Brazier requested the charting of the valve work be restored to the Operations Report included in the agenda packet.

**B. Representative Report (Appointed Representative)****1. SDCWA****A. Summary of Board Meeting March 22, 2018**

Mr. Kennedy gave a presentation on the Waterfix situation. He summarized the information provided in the handouts related to this topic.

**2. CSDA**

Mr. Kennedy noted the Quarterly Dinner meeting will be held on May 17, 2018 with a few speakers as well as awards being given to the winners of the video contest.

**3. LAFCO**

Mr. Kennedy mentioned there was some activity taking place related to the San Luis Rey Water District.

**4. San Luis Rey Watershed Council**

Director Gasca reported the Executive Director was called to other duties; therefore, the April 6, 2018 meeting is to be rescheduled.

**5. Santa Margarita River Watershed Watermaster Steering Committee**

Director Hamilton reported a scheduling issue prevented him from attending the meeting. He noted the minutes and agenda were provided to the Board for their reference.

**C. Meeting, Workshop, Committee, Seminar, Etc. Reports by Directors (AB1234)**

Director Gasca reported on the Council of Water Utilities meeting at which discussion took place regarding providing vision care to employees. Mrs. Harp noted RMWD utilizes VSP for District employee vision coverage.

**D. Directors Comments**

Director Hamilton talked about the water loss use for fire protection services or water main break going undetected. He explained insurance does not cover these types of water loss costs; therefore, he would like to suggest the Board discuss exploring third party insurance coverage for these abnormal types of situations at a future Board meeting. Mrs. Martinez agreed to look into this type of insurance and see what was available.

(\*) - Asterisk indicates a report is attached.

Director Mack announced he would not be attending the July Board meeting.

Director Hamilton announced he would not be attending the July Board meeting either; however, he will arrange to attend by teleconference if necessary.

Director Gasca talked about information he received regarding aqueduct work and maintenance scheduled to be conducted by SDCWA within RMWD’s boundaries without notifying the District. Mr. Kennedy noted he will attend the next meeting regarding this project to express the District’s concerns. Mrs. Gray stated at the most recent meeting, SDCWA acknowledged there was an oversight and they will present information to the Board as well as to the impacted customers going forward. Discussion followed.

**E. Legal Counsel Comments**

- 1. Attorney Report: Bid Protests and Cost Recovery (501668-0002)

Legal Counsel summarized the information provided in his report related to bid protests and cost recovery. He noted Mr. Kennedy has been informed as to how RMWD can minimize its risk with bidding contractors.

**\*9. COMMITTEE REPORTS (Approved Minutes have been attached for reference only.)**

**A. Budget and Finance Committee**

- 1. March 13, 2018 Minutes

Mr. Stitle reported the new accounting system implementation is expected to be completed in approximately one year. It was noted the Budget and Finance Committee will meet jointly with the Board of Directors at the May 22, 2018 Board meeting.

**B. Communications Committee**

- 1. March 1, 2018 Minutes

Mrs. Gray reported the committee discussed incorporating customer service into the committee name. She also noted there was great input from the committee regarding the 2018 Avocado Festival with excellent support from staff and Board Members. It was noted several customers stopped by to speak with those present at the booth.

Director Gasca pointed out it would be helpful to remind staff and Directors to bring their business cards as well as a FAQ sheet to capture any overflow of those visiting the booth.

Director Hamilton mentioned the committee also discussed changing the community tour to a video tour as opposed to a driving tour.

Director Hamilton announced the Vintage Car Show will be held on May 27, 2018 at Pala Mesa.

**C. Engineering Services Committee**

- 1. March 7, 2018 Minutes

Mr. Powers reported the committee discussed sewer service agreements, development updates, variance processes, as well as proposed changes to the committee charter.

(\*) - Asterisk indicates a report is attached.

**CONSENT CALENDAR**

- \*10. DISCUSSION AND POSSIBLE ACTION TO APPROVE ORDINANCE NO. 18-07 - AMENDING AND UPDATING ADMINISTRATIVE CODE CHAPTER 8.11 – CONNECTION AND METER CHARGES, SECTION 8.11.030 – WATER CAPACITY CHARGE
- \*11. DISCUSSION AND POSSIBLE ACTION TO APPROVE ORDINANCE NO. 18-08 - AMENDING AND UPDATING ADMINISTRATIVE CODE CHAPTER 4.01 – PERSONNEL RULES AND REGULATIONS
- \*12. DISCUSSION AND POSSIBLE ACTION TO APPROVE ORDINANCE NO. 18-09 - AMENDING AND UPDATING ADMINISTRATIVE CODE CHAPTER 8.02 – DEFINITIONS AND CHAPTER 9.02 - DEFINITIONS
- \*13. DISCUSSION AND POSSIBLE ACTION TO APPROVE ORDINANCE NO. 18-10 - AMENDING AND UPDATING ADMINISTRATIVE CODE CHAPTER 2.09 – COMMITTEES

***Motion:***

***To Approve the Consent Calendar.***

***Action: Approve, Moved by Director Hamilton, Seconded by Director Gasca***

***Vote: Motion carried by unanimous roll call vote (summary: Ayes = 4).***

***Ayes: Director Brazier, Director Hamilton, Director Mack, Director Gasca.***

***President Brazier called for a break at 2:50 p.m.***

***The meeting reconvened at 3:02 p.m.***

**BOARD ACTION ITEMS**

- \*14. DISCUSSION AND POSSIBLE ACTION TO APPROVE A SEWER SERVICE AGREEMENT BETWEEN RAINBOW MUNICIPAL WATER DISTRICT AND BEAZER HOMES HOLDINGS, LLC. PALA MESA HIGHLANDS, TM 5187-1 (MAP 16124)

Mr. Gerdes explained this was a 124-lot development with multiple contracts related to sewer capacity dating back to 1989. He stated the purpose for this item was to consolidate all the old agreements as well as address the costs involved into one sewer service agreement. He pointed out this agreement ensures the developer pays the appropriate amount to buy into the existing facilities that may be used by future homeowners in the development. He noted the total additional connection fee amounts to approximately \$1.3 million.

Director Hamilton asked with this reaching the 20-year agreement with extensions granted, does the agreement into which RMWD may enter guarantee the developer will pay the then going rates for sewer connections. He explained why he would not want to grant additional extensions. Mr. Kennedy stated the agreement includes a condition any extension would require mutual agreement between all parties including the Board.

(\*) - Asterisk indicates a report is attached.

**DRAFT**

**DRAFT**

**DRAFT**

**Motion:**

**Action:**

**Approve the Sewer Service Agreement.**

**Moved by Director Hamilton, Seconded by Director Mack.**

**Vote: Motion carried by unanimous vote (summary: Ayes = 4).**

**Ayes: Director Brazier, Director Hamilton, Director Mack, Director Gasca.**

**\*15. DISCUSSION AND POSSIBLE ACTION TO APPROVE SEWER SERVICE AGREEMENT FOR THE PALOMAR NORTH EDUCATION CENTER**

Mr. Gerdes reported the Palomar College campus was scheduled to open June 2018. He explained this agreement was a little different in that it memorializes the number of EDU's as well as includes conditions which must be met by Palomar prior to RMWD providing sewer service to the campus. He noted the sewer line has been extended; however, it cannot be completed until the construction on the lift station located on Pankey has been completed. He pointed out RMWD requires there be two additional RMWD manholes with an easement for possible future flow monitoring be put in place. He pointed out the agreement also cites past agreements for reimbursement costs totaling approximately \$130,000 that Palomar will pay RMWD and RMWD will in turn pay D.R. Horton.

Director Mack inquired about the lift station construction being complete by the opening date in June. Mr. Kennedy explained construction would not be complete; however, other alternatives were in place until the lift station was built.

Discussion ensued regarding the implemented spill prevention plan.

**Motion:**

**Approve Staff Recommendation Option 1 - Approve the Sewer Service Agreement which allows discharge of 100 EDUs to the District sewer system once the Horse Creek Lift Station is completed, accepted and operational. The Agreement also includes reimbursement from Palomar for the sewer stub constructed for the campus by D.R. Horton.**

**Action: Approve, Moved by Director Hamilton, Seconded by Director Gasca.**

**Vote: Motion carried by unanimous vote (summary: Ayes = 4).**

**Ayes: Director Brazier, Director Hamilton, Director Mack, Director Gasca.**

**\*16. DISCUSSION AND POSSIBLE ACTION TO APPROVE ORDINANCE NO. 18-11 AMENDING AND UPDATING ADMINISTRATIVE CODE TITLE 1 – GENERAL PROVISIONS**

Mr. Kennedy recalled the Board gave staff direction to draft policies related to variances. He reviewed the proposed variance procedures and policy.

(\*) - Asterisk indicates a report is attached.

**DRAFT**

**DRAFT**

**DRAFT**

President Brazier asked about variances when property is sold. Mr. Powers explained there were specified qualifications in terms of what types of agreements can be recorded to a title. He noted this policy was drafted to include any variance to the Administrative Code with allowances for agreements to be written and possibly recorded to property title when applicable.

Discussion ensued regarding allocations and the categorizing meter system.

Mr. Kennedy pointed out there would be two open public published meetings per variance.

**Motion:**

**Approve Ordinance No. 18-11.**

**Action: Approve, Moved by Director Hamilton, Seconded by Director Mack.**

**Vote: Motion carried by unanimous roll call vote (summary: Ayes = 4).**

**Ayes: Director Brazier, Director Hamilton, Director Mack, Director Gasca.**

**\*17. SAN DIEGO COUNTY CONSOLIDATED REDEVELOPMENT OVERSIGHT BOARD CALL FOR BALLOTS**

Mr. Kennedy explained LAFCO was tasked with dealing with the windup of the redevelopment agencies and are required by statute to develop an oversight board. He stated only those agencies who have money at stake are going to be on the Board which would not include RMWD.

**Motion:**

**To nominate Julie Nygaard.**

**Action: Approve, Moved by Director Mack, Seconded by Director Gasca.**

**Vote: Motion passed (summary: Ayes = 3, Noes = 1, Abstain = 0).**

**Ayes: Director Brazier, Director Mack, Director Gasca.**

**Noes: Director Hamilton.**

**18. AUTHORIZATION TO ATTEND UPCOMING MEETINGS / CONFERENCES / SEMINARS**

Mr. Kennedy mentioned Director Stewart requested the Board consider changing the May 22<sup>nd</sup> Board meeting date to May 29<sup>th</sup>. It was noted there would be a quorum present on both days and should the Board not make a motion, the meeting will remain on schedule for May 22<sup>nd</sup>.

Mr. Kennedy pointed out the budget would be reviewed, but not approved at the May meeting.

No action taken.

(\*) - Asterisk indicates a report is attached.

**BOARD INFORMATION ITEMS**

**19. STRATEGIC PLAN OBJECTIVES UPDATES**

Mr. Kennedy recalled at the last meeting the Board was presented with updates on the strategic planning objectives and were asked to provide staff with input regarding any changes they would like to have made to the plan.

Director Gasca suggested the well water project.

Discussion ensued regarding researching opening voting rights for property owners as opposed to residents only.

Director Gasca suggested infrastructure security be added to the strategic plan. It was noted this would be under asset management.

Director Mack requested a cost analysis be conducted for leasing versus purchasing fleet vehicles. Discussion followed.

Mr. Kennedy noted the next time this item is reviewed the completed items will be moved down the list and new ones added with an anticipated meeting with the consultant to take place in August. He encouraged the Board to review the strategic plan items and provide any input and feedback to the District.

**20. STAFFING ANALYSIS PRESENTATION**

Mrs. Harp presented an updated staffing analysis with a comparison of 2017 and current data. She noted there will be a 2018-2019 forecast provided with recommendations at the next Board meeting.

Discussion ensued regarding the trend changes in overtime as well as possible temporary or long-term part-time positions that may be considered.

Mrs. Harp noted this was the first RMWD has a full year of EAM data to look at which will provide a good benchmark for use in future year comparisons. She also mentioned there may be some organizational changes in the Finance Department. Mr. Kennedy offered to have this presentation emailed to the Board for their reference.

It was noted the safety hour component was missed in this analysis report.

***The meeting adjourned to the Rainbow Public Facilities Corporation meeting at 4:58 p.m.***

***The meeting reconvened at 5:06 p.m.***

**\*21. RECEIVE AND FILE INFORMATION AND FINANCIAL ITEMS**

- A. General Manager Comments**
  - 1. Meetings, Conferences and Seminar Calendar
- B. Communications**
  - 1. Staff Training Reports
- C. Operations Comments**
  - 1. Operations Report

(\*) - Asterisk indicates a report is attached.

***DRAFT***

***DRAFT***

***DRAFT***

- D. Engineering Comments**
  - 1. Engineering Report
- E. Customer Service and Meters Comments**
  - 1. Customer Service and Meters Report
- F. Human Resource & Safety Comments**
  - 1. Human Resources Report
- G. Finance Comments**
  - 1. Interim Financial Statement
  - 2. Treasurer Report
  - 3. Credit Card Breakdown
  - 4. Directors' Expense
  - 5. Check Register
  - 6. Water Sales Summary
  - 7. RMWD Sewer Equivalent Dwelling Units (EDU's) Status

Mr. Kennedy presented information on a recent theft at one of RMWD's facilities. He pointed out the addition of security at facilities to the strategic plan would be beneficial. Discussion ensued.

Director Hamilton asked if there was an official cause reported for the Lilac Fire. It was confirmed no official cause has been reported.

Mrs. Harp announced an offer was made and accepted for the Safety position. She also extended an invitation to the Board to attend RMWD's 2018 Health Fair and Bring Your Kids to Work Day as well as participate in the CPR classes taking place in May.

***Motion:***

***To receive and file information and financial items.***

***Action: Approve, Moved by Director Hamilton, Seconded by Director Mack.***

***Vote: Motion carried by unanimous vote (summary: Ayes = 4).***

***Ayes: Director Brazier, Director Hamilton, Director Mack, Director Gasca.***

**22. LIST OF SUGGESTED AGENDA ITEMS FOR THE NEXT REGULAR BOARD MEETING**

It was noted this will be a joint meeting with the Budget and Finance Committee to include review of the preliminary budget, strategic plan, and staffing analysis.

**23. ADJOURNMENT - To Tuesday, May 22, 2018 at 1:00 p.m.**

***The meeting was adjourned with a motion made by Director Brazier to a joint Budget and Finance and Board meeting on May 22, 2018 at 1:00 p.m.***

The meeting was adjourned at 5:23 p.m.

---

**Helene Brazier, Board President**

---

**Dawn M. Washburn, Board Secretary**

(\*) - Asterisk indicates a report is attached.





**TO:** Rainbow Municipal Water District  
**FROM:** Alfred Smith  
**DATE:** May 22, 2018  
**RE:** Attorney Report: Endangered Species and Water Projects  
501668-0002

---

**I. INTRODUCTION.**

This attorney report provides an update on two recent cases regarding the Endangered Species Act. Last month, the Ninth Circuit Court of Appeals issued two rulings regarding water projects in cases brought to enforce the Endangered Species Act (ESA).

On April 2, 2018, in *National Wildlife Federation v. National Marine Fisheries Service (National Wildlife Federation)*, Case Number 17-35462, the Ninth Circuit Court affirmed injunctive relief granted by the United States District Court partially granting and partially denying Plaintiffs' requested relief regarding ESA listed salmon and steelhead.

On April 5, 2018, in *Defenders of Wildlife v. United States Army Corps of Engineers (Defenders of Wildlife)*, Case Number 17-35712, the Ninth Circuit reversed the U.S. District Court's grant of preliminary injunction regarding projects affecting the listed pallid sturgeon.

At first blush, these two decisions present seemingly contrasting approaches to endangered species enforcement issues for water projects. Nonetheless, both decisions provide guidance on the fundamental principles that will be considered by the courts when there are endangered species issues affecting the implementation of water projects. The cases examine the often conflicting legal standards for environmental review of projects under the ESA and CEQA, the level of deference to be given local agency determinations, and the scope of mitigation that is necessary to satisfy conservation standards.

## **II. National Wildlife Federation**

*National Wildlife Federation* is the most recent decision in nearly two decades of court oversight of the Federal Columbia River Power System (FCRPS) -- a series of dams and related facilities on the Snake and Columbia Rivers in Montana, Idaho, Oregon, and Washington. This latest decision stems from injunctive relief requested by the National Wildlife Federation and the State of Oregon, based on the successful challenge to the National Marine Fisheries Service's (NMFS) 2014 Biological Opinion adjudicated in a prior decision known as *NWF V*. The decision in *NWF V* determined that NMFS's 2014 Biological Opinion for operation of the FRCPS violated the ESA: in particular, a no-jeopardy determination for listed salmon and steelhead was held to be improper.

The District Court required that, until NMFS issues a new Biological Opinion at the end of 2018, the Bureau of Reclamation (Bureau) and the Army Corps of Engineers (Corps) must increase spill operations at FCRPS facilities to the maximum level that meets dissolved gas criteria under state law. The federal agencies must also operate juvenile bypass facilities and associated tagging operations at FCRPS dams.

The District Court held that the plaintiffs did not, in order to be entitled to the requested relief, need to demonstrate an imminent threat at the species level during the two-year remand period for NMFS to revise the Biological Opinion. Nor did plaintiffs have to demonstrate that the existing spill-related operations *specifically* cause irreparable harm to the listed species. The District Court instead relied on voluminous factual findings made in the course of the on-going litigation that demonstrated the precarious position of the listed species and species' exposure to harm through the operations of the FCRPS.

On appeal, the Federal defendants argued that the District Court abused its discretion in granting the requested relief, based on an erroneous finding of irreparable harm and failure to properly tailor the relief to specific causes of irreparable harm. The federal agencies challenged the finding of irreparable harm based on two grounds: the District Court's failure to find an extinction level risk to the listed species *during* the two-year remand period; and the District Court's consideration of *overall* harm of the FCRPS to the listed species, rather than harms caused by spill operations. The Ninth Circuit rejected these contentions and affirmed the District Court's ordered relief.

To review the relief ordered by the District Court, the Ninth Circuit analyzed the District Court's finding of irreparable harm. The rise of irreparable harm is the crucial element courts must determine if injunctive relief is appropriate for ESA violations. The other elements of the traditional injunctive relief test, including the public interest and balancing of equities, ordinarily tip in favor of protecting species. In *National Wildlife Foundation*, the Ninth Circuit found that the District Court properly found the requisite irreparable harm to both the species and the plaintiffs.

The Ninth Circuit dismissed the federal defendants' argument that injunctive relief is only available when an extinction level threat is present. The Ninth Circuit relied on principles that irreparable harm does not equate to extinction level threats under the ESA. The Ninth Circuit clarified that such injunctive relief *may be* appropriate for certain procedural violations of Section 7 of the ESA, particularly where there is not a valid Biological Opinion in place that determines acceptable levels of incidental take compliant with what the Ninth Circuit's interprets as the ESA's animating principle—conservation of listed species.

The Ninth Circuit also dismissed the argument that the ordered injunctive relief was not properly tailored to the harms found. The Ninth Circuit rejected the federal defendants' contention that narrowly tailored injunctive relief match up precisely with the found irreparable harm, requiring only a sufficient causal connection between the irreparable harm found and the requested relief. Notably, the Ninth Circuit considered the long history of this particular case—including a similar spill injunction in 2005 and consistent findings of the listed species' precarious nature—in determining that the District Court's finding of irreparable harm was not erroneous. Additionally, the Ninth Circuit found that even though the federal defendants raised a degree of scientific uncertainty, this uncertainty did not render the District Court's findings clearly erroneous in this case.

### **III. Defenders of Wildlife**

In *Defenders of Wildlife*, the Ninth Circuit vacated the District Court's order granting preliminary injunctive relief after addressing findings by the District Court regarding irreparable harm and plaintiffs' likelihood of success on the merits.

*Defenders of Wildlife* involves the proposed construction of a concrete weir on Montana's Yellowstone River to replace an existing wooden weir and the construction of a fish passage bypass channel that would allow the endangered pallid sturgeon to swim

around the weir and reach spawning grounds. The channel was modeled, in part, on the successful use of a natural side channel by the listed species during high flows in 2014. This decision marks the second time courts blocked the project—and later allowed the project to move forward based on the sufficiency of federal agency environmental review. At issue in this latest case was the no-jeopardy determination regarding the project from the federal agencies' revised NEPA and ESA documents issued at the end of 2016.

The Ninth Circuit found two critical errors regarding the District Court's irreparable harm analysis. First, the District Court improperly considered harm caused by the "continued operation" of existing infrastructure in determining irreparable harm, primarily because plaintiffs did not seek to enjoin such existing operations. Second, the District Court "flipped the burden of proof" when it required the Corps to prove that its proposed project would allow successful fish passage, rather than requiring Defenders of Wildlife to demonstrate irreparable harm from construction of the proposed project. These two mistakes amounted to abuse of discretion by the District Court when it found irreparable harm.

The Ninth Circuit also determined that the District Court committed legal error when it found that Defenders of Wildlife was likely to succeed on the merits of its claim. Specifically, regarding the ESA claim, the District Court found that the absence of specific Incidental Take Statement analysis and quantifiable recovery goals were deficiencies that did not support a no-jeopardy determination. However, the Ninth Circuit found that while these elements may *sometimes* be required to support a no-jeopardy determination, they were not required in this instance. The Corps articulated a reasoned—and reasonable—basis for its no-jeopardy finding because the project would result in a substantial reduction to breeding impairments to the pallid sturgeon.

Still pending before the District Court is Defenders of Wildlife's motion for summary judgment. It remains to be seen how the District Judge will treat this motion, given the Ninth Circuit's overturning of the ordered injunctive relief.

#### **IV. CONCLUSION.**

These two cases concerning the appropriate standards and principles for injunctive relief provide insight into how the Ninth Circuit approaches continuing litigation under the ESA. Central in each decision is the animating purpose of the

ESA—protection and conservation of listed species. In both opinions, the Ninth Circuit relied on findings that actions would benefit the listed species.

In *National Wildlife Foundation*, the benefit favored injunctive relief. In *Defenders of Wildlife*, however, the benefit stemmed from the challenged Corps' project—and deference to the agency's finding of this benefit was appropriate because the record established sufficient evidence that the project would *benefit* listed species by increasing access to spawning grounds.

Additionally, the distinction in the Ninth Circuit's approach to agency determinations in light of sufficient environmental study is worth noting. Where the consulting agency—and the appropriate wildlife agency—have compiled a record designed to further the goals of the ESA, the Ninth Circuit appears willing to afford deference and deny environmentalist challenges.

In *Defenders of Wildlife*, the agencies initially failed to conduct a full environmental analysis in 2015; however, the agencies issued revised environmental documents at the end of 2016, which the Ninth Circuit found sufficiently documented the basis for a no-jeopardy determination for the proposed project. This determination was therefore entitled to deference and the District Court erred in finding an insufficient basis to support that determination.

However, as *National Wildlife Foundation* demonstrates, failure to compile environmental documents that meet with court approval, coupled with a lengthy record containing “ample evidence . . . that the FCRPS causes substantial harm to listed salmonids,” will likely result in extended litigation and continuing court oversight to ensure that agencies—and by extension, issued regulatory permits—implement ESA goals.

Working within the bounds of the ESA is a complicated process involving multiple stakeholders. Together, the decisions reinforce that agencies seeking ESA authorization will be entitled to deference if they develop and document an environmental record that: (1) furthers the goals of the ESA by showing no jeopardy to listed species; (2) contains mitigation measures that “substantially reduce” the impairment to listed species; (3) contains “ample technical evidence” showing benefits to listed species; and (4) contains quantifiable recovery goals.



**MINUTES OF THE BUDGET AND FINANCE COMMITTEE MEETING  
OF THE RAINBOW MUNICIPAL WATER DISTRICT  
APRIL 10, 2018**

1. **CALL TO ORDER:** The Budget & Finance Committee meeting of the Rainbow Municipal Water District was called to order by Chairperson Stitle on April 10, 2018 in the Board Room of the District Office at 3707 Old Highway 395, Fallbrook, CA 92028 at 1:00 p.m. Chairperson Stitle presiding.

2. **PLEDGE OF ALLEGIANCE**

3. **ROLL CALL:**

**Present:** Member Stitle, Member Ross, Member Hensley, Member Moss, Member Gasca.

**Also Present:** General Manager Kennedy, Executive Assistant Washburn, Alternate Nelson, Alternate Martinez.

One member of the public was present.

4. **SEATING OF ALTERNATES**

There were no alternates seated at this meeting.

5. **ADDITIONS/DELETIONS/AMENDMENTS TO THE AGENDA (Government Code §54954.2)**

Mr. Kennedy reported Item #10 would be pulled from the agenda.

6. **PUBLIC COMMENT RELATING TO ITEMS NOT ON THE AGENDA (Limit 3 Minutes)**

There were no comments.

**COMMITTEE ACTION ITEMS**

7. **COMMITTEE MEMBER COMMENTS**

Ms. Moss reported on the Citizens Water Academy she recently attended noting the use of Olivenain's reservoir was most fascinating. She said she found the academy to be very interesting and educational and impressive.

Discussion ensued regarding the proposed Twin Tunnels being voting on by Metropolitan Water District today.

**\*8. APPROVAL OF MINUTES**

**A.** March 13, 2018

Mr. Ross noted “he” should be “his” on Item #9.

***Motion:***

***Approve the minutes as revised.***

***Action: Approve, Moved by Member Gasca, Seconded by Member Hensley.***

***Vote: Motion carried by unanimous vote (summary: Ayes = 5).***

***Ayes: Member Stitle, Member Ross, Member Hensley, Member Moss, Member Gasca.***

**9. TELEPHONE CONFERENCE CALL WITH DISTRICT’S INVESTMENT ADVISOR**

Ken Edelman introduced himself to the committee as well as brief them on his background and experience prior to reviewing the specifics involved with RMWD’s investments.

Mrs. Martinez explained the conclusion of the audit prompted this teleconference with the District’s advisor today. Mr. Edelman reported on RMWD’s current portfolio, including RMWD has cash that was not earning much interest. He confirmed RMWD was in a very good position and provided suggestions for RMWD in terms of investments.

Mr. Kennedy inquired about the recent auditor comments. Mrs. Martinez recommended some funds be deposited into LAIF. Mr. Gasca pointed the auditor’s concern seems to suggest RMWD move funds. Mrs. Martinez explained the auditor was making a comparison to another agency.

Mrs. Martinez talked about short term investment benefits. Mr. Kennedy added after some time there may be a need to shift developer funds to long term investments.

Mr. Edelman noted he keeps a watch on RWMD’s portfolio to find any opportunities of which the District may want to take advantage. He elaborated on the types of opinions he would provide to RMWD to keep the District making the best investments as well as the overall portfolio in a good position.

Mr. Ken thanked the committee for the invitation to speak. He said he would be happy to answer any questions and assist wherever necessary.

Mrs. Martinez offered to look at the current rates for the Federal Home Loan Mortgage Corporation as well as Caterpillar Financial Corporation.

Mr. Stitle inquired as to the overall return on investments. Mr. Kennedy answered it was approximately \$200,000. Discussion followed.

**10. DISCUSSION REGARDING REQUEST FOR PROPOSAL FOR PAYROLL SERVICES**

This item was pulled from the agenda per Item #5.



**11. DISCUSSION REGARDING REQUEST FOR PROPOSAL FOR GASB 75**

Mrs. Martinez noted GASB 75 was made a part of the auditor report related to employee post-retirement benefits. Mr. Kennedy explained the changes to RMWD's post-retirement benefits that transpired during the 2017 negotiations with the bargaining units.

Mr. Gasca asked why the Request for Proposal was for every two years. Mrs. Martinez explained this was the minimum requirements and why RMWD would not want it to be more frequent.

**12. ABM**

Mr. Kennedy briefed the committee on the history and background on the project. He gave an update including how the parties involved were back in discussions in hopes of resolving some of the issues. He stated it was anticipated there would be someone making a presentation at the next committee meeting.

**13. REVIEW THE FOLLOWING:**

- A. Income Statement
- B. Balance Sheet
- C. Cash Flow
- D. Treasurer's Report

Mrs. Martinez summarized the developer projections provided in a handout. Discussion took place regarding some of the projects listed.

Mr. Hensley inquired as to how close past forecasts have been when it comes to development projects. Mr. Kennedy explained how the projections are made. Discussion ensued regarding current housing pricing.

Mrs. Martinez explained the information contained in the income statement, Discussion ensued regarding the City of Oceanside agreement with RMWD.

Discussion took place on the balance sheet information.

**14. LIST OF SUGGESTED AGENDA ITEMS FOR THE NEXT SCHEDULED BUDGET AND FINANCE COMMITTEE MEETING**

It was noted Item #10, the preliminary budget, as well as scheduling the joint meeting with the Board of Directors for May 22, 2018 to review the budget.

**15. ADJOURNMENT**

*The meeting was adjourned with a motion made by Member Stitle.*

The meeting adjourned at 2:15 p.m.

---

**Harry Stitle, Committee Chairperson**

---

**Dawn M. Washburn, Board Secretary**



**MINUTES OF THE COMMUNICATIONS COMMITTEE MEETING  
OF THE RAINBOW MUNICIPAL WATER DISTRICT  
APRIL 5, 2018**

1. **CALL TO ORDER** – The Communications Committee Meeting of the Rainbow Municipal Water District on April 5, 2018 was called to order by Chairperson Daily at 3:33 p.m. in the Board Room of the District, 3707 Old Highway 395, Fallbrook, CA 92028. Chairperson Daily, presiding.

2. **PLEDGE OF ALLEGIANCE**

3. **ROLL CALL:**

**Present:** Member Daily, Member Kirby, Member Hamilton, Alternate Gray.

**Also Present:** General Manager Kennedy, Executive Assistant Washburn.

**Absent:** Member Kurnik.

Four members of the public were present.

4. **SEATING OF ALTERNATES**

Mr. Daily noted Mrs. Gray will be seated as an alternate at this meeting.

5. **ADDITIONS/DELETIONS/AMENDMENTS TO THE AGENDA (Government Code §54954.2)**

It was noted the date on the agenda was incorrect.

6. **PUBLIC COMMENT RELATING TO ITEMS NOT ON THE AGENDA**

A member of the public introduced herself to the committee noting her family has property off Rainbow Road that belonged to her father since the 1970's. She said she wants to get more involved with water matters facing the community. She talked about the American Farm Bureau and how it peaked her interest to start collecting information and data on water matters facing the community.

Mr. Kennedy explained this was the communications committee meeting which talks about better means of communicating with RMWD's customers. The committee members introduced themselves.

**COMMITTEE ACTION ITEMS**

\*7. **APPROVAL OF MINUTES**

A. March 1, 2018

Ms. Gray noted "discussion" needed to be removed in Item #14.

***Motion:***

***To approve the minutes as revised.***

***Action: Approve, Moved by Member Hamilton, Seconded by Member Kirby.***

***Vote: Motion carried by unanimous vote (summary: Ayes = 4).***

***Ayes: Member Daily, Member Kirby, Member Hamilton, Alternate Gray.***

**8. DISCUSSION REGARDING COMMUNITY EVENTS**

- A. Polo Shirt Update for Community Events
- B. Avocado Festival - April 15, 2018
- C. Vintage Car Show - May 27, 2018

Mrs. Gray announced a test run of polo shirts have arrived for use at the upcoming community events. Discussion ensued regarding the difficulties faced when ordering materials with the RMWD logo; therefore, a discussion regarding possibly changing the logo may be on the next committee agenda.

Discussion ensued regarding committee members' role at community events.

Mr. Kennedy mentioned an equipment display and video would be set up at the festivals. Mrs. Gray noted all the other materials would be arriving in the next week and that she would be providing a schedule of who will be working the booth and when to committee members for their reference.

**9. PUBLIC TOUR PRESENTATION REVIEW**

Discussion ensued regarding feedback from the tour preview.

Mr. Hamilton asked if these would be run on a regular schedule. Mr. Kennedy explained notification would be provided in the newsletters when a tour is scheduled and depending on interest more tours will be added. Mr. Hamilton recommended there be people prepared to speak during the tours should the main presenter be unable to attend.

Discussion took place regarding creating a virtual tour as opposed to spending too much time driving on site visits. It was noted the goal was to give the customers as much information about the District in the most efficient manner.

**10. DISCUSSION REGARDING CUSTOMER SERVICES**

Mr. Kennedy noted recently the Engineering Committee reviewed their charter which will be brought to the Board for possible amendment. He mentioned a recent situation may be cause for this committee to consider possibly amending its charter as well to include customer service in terms of interpreting and reviewing policies and procedures related to customer-related matters.

Mr. Daily stated this addition would be beneficial for communicating with the public. It was confirmed the committee could be assisting by advising the Board on potential policy changes.

Mr. Hamilton explained when it comes to customer service, there is no defined policy and practice for escalation should a customer not be satisfied with the response received. He explained how having a defined policy and practice would benefit RMWD's customer service representatives.

The public member noted for younger Californians, consistency, accountability, and transparency are vital. She suggested gathering data and translating everything to numbers would be important when looking at defining policies and procedures.

**11. MUNICIPAL SEWER AND WATER VIDEO**

**A. Article Plaque for Lobby**

Mr. Kennedy shared the recent MSW Magazine video with the committee. Discussion ensued regarding a video made on the history of the District as well as for FAQ's.

Mr. Kennedy talked about how an article plaque would be a good addition to the main office as a means of sharing it with the public. It was decided to proceed with purchasing one.

**12. DISCUSSION REGARDING POSSIBLY RESCHEDULING MAY 3, 2018 COMMUNICATIONS COMMITTEE MEETING**

Mr. Daily announced changing the meeting date no longer needed to be discussed.

**13. PUBLIC COMMUNICATIONS AND OUTREACH ITEMS**

**A. Topics**

Mr. Kennedy mentioned the water supply update provided in the April 2018 newsletter.

It was noted the upcoming 2018 elections should be published in the June 2018 newsletter.

**B. Strategic Plan Objectives**

Discussion ensued regarding press releases.

Mr. Kennedy said he would talk about the communications committee objectives with the Board at the April meeting.

**C. Calendar**

Mr. Daily asked if there was anything coming up that should be mentioned in public communications.

Discussion ensued regarding topics for the first extended newsletter and the costs involved. It was decided EAM and condition assessment should be the first topic.

**D. Snipes Calendar**

**14. REVIEW AND ANALYSIS OF RMWD RELATED MEDIA STORIES**

Mr. Daily shared the Rainbow Property owners article that mentioned RMWD as well as the "Keeping the Taps Flowing" article published in The Village News.

**15. COMMITTEE MEMBER COMMENTS**

There were no comments.

**16. LIST OF SUGGESTED AGENDA ITEMS FOR THE NEXT SCHEDULED COMMUNICATIONS COMMITTEE MEETING**

It was noted the charter amendment, discussion regarding changing the logo, Avocado Festival debrief, and extended newsletter draft should to be on the next agenda.

**17. ADJOURNMENT**

*The meeting was adjourned by a motion made by Member Daily.*

The meeting adjourned at 4:58 p.m.

---

**Mike Daily, Committee Chairperson**

---

**Dawn M. Washburn, Board Secretary**

**MINUTES OF THE ENGINEERING SERVICES COMMITTEE MEETING  
OF THE RAINBOW MUNICIPAL WATER DISTRICT  
APRIL 4, 2018**

1. **CALL TO ORDER** – The Engineering Services Committee Meeting of the Rainbow Municipal Water District on April 4, 2018 was called to order by Chairperson Prince at 3:00 p.m. in the Board Room of the District, 3707 Old Highway 395, Fallbrook, CA 92028. Chairperson Prince, presiding.

2. **PLEDGE OF ALLEGIANCE**

3. **ROLL CALL:**

**Present:** Member Prince, Member Stitle, Member Brazier, Member Taufer, Member Ratican, Member Marnett, Alternate Nelson.

**Also Present:** General Manager Kennedy, Associate Engineer Powers, Eng. Technician Rubio, Right of Way/Facilities Coordinator Brown.

**Absent:** Alternate Kirby, Member Robertson.

There were no members of the public present.

4. **SEATING OF ALTERNATES**

Alternate Member Nelson was invited to take a voting seated.

5. **ADDITIONS/DELETIONS/AMENDMENTS TO THE AGENDA (Government Code §54954.2)**

Mr. Kennedy requested postponing Agenda Item 8 to next month's meeting. He stated the data was incomplete.

6. **PUBLIC COMMENT RELATING TO ITEMS NOT ON THE AGENDA**

There were no public comments.

**COMMITTEE ACTION ITEMS**

\*7. **APPROVAL OF MINUTES**  
A. March 7, 2018

Mr. Taufer said he wanted to submit his comments regarding the Condition Assessment report during a meeting with Mr. Powers, right after the Engineering Committee meeting.

**Motion:** Approve the minutes as written.

**Action:** Approve, Moved by Member Brazier, Seconded by Member Stitle.

**Vote: Motion carried by unanimous roll call vote (summary: Ayes = 7)**

**Ayes: Member Prince, Member Stitle, Member Brazier, Member Taufer, Member Ratican, Member Marnett, Alternate Nelson.**

**8. DISCUSSION REGARDING SEWER FLOW MONITORING OPTIONS**

Agenda Item postponed to next month's meeting.

**\*9. DEVELOPMENT PROJECTS UPDATE – DISCUSSION ON SEWER PERMIT ADMINISTRATIVE CODE AND SEWER SERVICE AGREEMENTS FOR PROJECTS WITH MORE THAN FIVE EDU'S**

Mr. Powers said Mr. Gerdes had been working on the sewer service agreements for Pala Mesa Highlands and Palomar College. He summarized the current development projects as follows:

- Golf Green Estates: Located by Bonsall Elementary, 21 meters purchased, most of the wet infrastructure was complete, and models were completed.
- DR Horton: Located on Horse Creek Ridge, 216 meters purchased, currently complying with the District's regulation regarding the temporary lift station, permanent lift station on Pankey Road expected to be completed in June 2018.
- Pala Mesa Highlands: Located on Old Highway 395, past Nussy Burgers, 124 lots, about 90% completion of wet infrastructure.

Mr. Powers said last year there were changes to the District's Admin Code regarding the purchase of more than 5 sewer EDUs. He continued based on these changes the existing agreements needed to be revised. He explained the revised sewer service agreements would include memorializing any previous payments, and clarifying that any payments receive were not directly tied to specific number of EDUs. He pointed out the reason these sewer agreements were brought to the engineering committee was to provide an update on changes to the developer process, and explain the purpose of the sewer service agreements. Discussion ensued.

Mr. Kennedy paused to introduce a new District staff member Ms. Brown, Right of Way/Facilities Coordinator. He said Ms. Brown came from working on Catalina Island, running the water system for Edison and is a registered geologist.

Mr. Kennedy stated the reason for changing the sewer policy was to have the ability to expire older agreements. He explained the goal for the District was to have developers come in earlier in the process and get the last of the legacy agreements through the system.

Mr. Ratican asked if the District's ordinance covered vesting tentative maps. Mr. Powers responded he did not believe it did. Mr. Ratican suggested looking into it. Discussion ensued.

Mr. Kennedy said there was currently no agreement in place with Palomar Community College. He mentioned the agreement would have terms regarding how to track the 100 EDUs and what would happen if these EDUs are close to being all used. He stated that sewer flow monitoring meters would be installed to ensure controls and caps. He said Palomar purchased a 4-inch water meter and had a separate irrigation meter. Discussion ensued.



## 10. DISCUSSION REGARDING CAPACITY CLASS VARIANCE AGREEMENT

Mr. Kennedy said currently per the District's Admin Code a lot that was over half an acre required a 1-inch meter. He mentioned one customer had requested a smaller meter for a large lot, although presently there were a couple more customers with similar requests. He said the requested variance from policy was brought to the Board for direction and it was returned to staff for further review/analysis. He stated that preparation of a variance agreement to track any offenses and ensure compliance would be problematic due to limitations of proposition 218. He pointed out a solution, which was suggested by legal counsel, to construct a fee based on the capacity fees. He mentioned using a tier rate to apply the fees would be possible if reasonably calculated. Discussion ensued.

Mr. Kennedy provided a draft concept spreadsheet he developed and proceeded with an explanation on the mechanism for applying capacity charges. He went over the parameters for applying the fee for use beyond a determined volume using 6 or 12-month rolling averages. Discussion ensued.

Mr. Kennedy mentioned staff were currently reviewing other District and City policies which are already in place to use as a basis for our own variance policy.

Mr. Stitle suggested adding a column with percentages of customers effected, to the draft concept spreadsheet.

Mr. Powers discussed a calculation used at Vallecitos Water District for customers that over use sewer and water capacity. He explained by applying a 10 year lease of capacity divided out over the number of units and the number of months one could find a fee per unit for over use. Discussion ensued.

## 11. DISCUSSION REGARDING REVISIONS TO THE ENGINEERING SERVICES COMMITTEE CHARTER

Mr. Kennedy said last month there was a request to review the changes to the Engineering Services Committee charter and return with any comments.

**Motion: Approve the revised Engineering Services Committee charter.**

**Action: Approve, Moved by Alternate Nelson, Seconded by Member Marnett.**

**Vote: Motion passed (summary: Ayes = 6, Noes = 1, Abstain = 0).**

**Ayes: Member Prince, Member Stitle, Member Brazier, Member Ratican, Member Marnett, Alternate Nelson.**

**Noes: Member Taufer.**

## 12. ABM METER REPLACEMENT PROJECT UPDATE

Mr. Kennedy said there has not been any progress to date. He mentioned if the delays were not corrected soon the District may need to fund the project a different way. Discussion ensued.

**13. LIST OF SUGGESTED AGENDA ITEMS FOR THE NEXT SCHEDULED ENGINEERING SERVICES COMMITTEE MEETING**

The following agenda items were suggested:

- Sewer Monitoring Options
- ABM Update
- Variance Process

**14. ADJOURNMENT**

**Motion:** To adjourn the meeting

**Action:** Approve, Moved by Member Prince, Seconded by Member Stitle.

**Vote:** Motion passed (summary: Ayes = 7, Noes = 0, Abstain = 0).

**Ayes:** Member Prince, Member Stitle, Member Brazier, Member Ratican, Member Marnett, Alternate Nelson, Member Taufer.

---

**Timothy Prince, Committee Chairperson**

---

**Dawn M. Washburn, Board Secretary**

---

**BOARD OF DIRECTORS**

May 22, 2018

---

**SUBJECT**

DISCUSSION AND POSSIBLE ACTION TO APPROVE ORDINANCE NO. 18-12 - AMENDING AND UPDATING ADMINISTRATIVE CODE SECTION 1.02.020 – CONFLICT OF INTEREST

**BACKGROUND**

In reviewing Administrative Code Section 1.02.020, it was realized the definition provided for Auditor erroneously referenced standing committees.

**DESCRIPTION**

Section 1.02.020 has been revised to replace standing committees to auditors in the definition provided for Auditor.

**POLICY/STRATEGIC PLAN KEY FOCUS AREA**

Administrative Code Section 1.02.020

Strategic Focus Area Three: Workforce Development

**BOARD OPTIONS/FISCAL IMPACTS**

- 1) Approve Ordinance No. 18-12 amending and updating Administrative Code Section 1.02.020.
- 2) Approve Ordinance No. 18-12 amending and updating Administrative Code Section 1.02.020 with revisions.
- 3) Provide staff with further direction.
- 4) Do not approve Ordinance No. 18-12 amending and updating Administrative Code Section 1.02.020.

There will be no known direct fiscal impact associated with any of the Board Options.

**STAFF RECOMMENDATION**

Approve Ordinance No. 18-12 amending and updating Administrative Code Section 1.02.020.



---

Tom Kennedy, General Manager

May 22, 2018



**Ordinance No. 18-12**

**Ordinance of the Board of Directors of the Rainbow Municipal Water District  
Amending the Administrative Code  
Section 1.02.020 – Conflict of Interest**

WHEREAS, the Rainbow Municipal Water District has, from time to time, adopted various rules and regulations for the operation of the District; and

WHEREAS, certain of those rules and regulations require updating to reflect best practices, as well as changes in applicable laws; and

WHEREAS, the Board of Directors has determined that changes in the rules or regulations of the District shall occur solely by amendment to the Administrative Code;

NOW, THEREFORE,

BE IT ORDAINED by the Board of Directors of Rainbow Municipal Water District as follows:

1. The following rules and regulations of the District, collected are hereby adopted and shall be incorporated into the Administrative Code, consisting of:

Section 1.02.020: Conflict of Interest

2. The General Manager is hereby directed to update the Administrative Code to reflect the approval of these rules and regulations, and to assign or reassign the numbering of the Administrative Code as necessary to codify these rules and regulations as amended.

3. This ordinance shall take effect immediately upon its adoption on this 22nd day of May 2018.

**AYES:**  
**NOES:**  
**ABSTAIN:**  
**ABSENT:**

\_\_\_\_\_  
Helene Brazier, Board President

**ATTEST:**

\_\_\_\_\_  
Dawn Washburn, Board Secretary



**Section 1.02.020**  
**Conflict of Interest**

**1.02.020.01** The Political Reform Act (Government Code Section 81000, et seq.) requires state and local government agencies to adopt and promulgate conflict of interest codes. The Fair Political Practices Commission has adopted a regulation (2 Cal. Code Regs. Section 18730) that contains the terms of a standard conflict of interest code and may be incorporated by reference in any agency's code. After public notice and hearing, the standard code may be amended by the Fair Political Practices Commission to conform to amendments in the Political Reform Act.

**1.02.020.02** Therefore, the terms of 2 California Code of **Regulations Section 18730** and any amendments to it duly adopted by the Fair Political Practices Commission are hereby incorporated by reference. This regulation and the attached Appendix designating positions, and establishing disclosure requirements, shall constitute the conflict of interest code of the Rainbow Municipal Water District.

**1.02.020.03** Individuals holding designated and non-designated positions shall file their Statements of Economic Interest with Rainbow Municipal Water District, which will make the statements available for public inspection and reproduction. (Gov. Code Section 81008.) Upon receipt of the statements for the Board Members and General Manager, the Board Secretary shall make and retain copies and forward the originals of these statements to the County Board of Supervisors. Statements for all other designated employees shall be retained by Rainbow Municipal Water District.

Any public officials who manage public investments shall be considered non-designated positions under Government Code section 87200 and shall make the disclosures required by law. Originals of all Statements of Economic Interest filed by non-designated positions will be maintained at the District office.

\\rmwd-b\Store02\DriveC\Data\Drive-E\ADMINISTRATIVE\_CODE\Drafts Not Approved\Conflict of Interest 1.02.020.docx~~\\rmwd-b\Store03\BoardFiles\Board Secretary\Administrative Code Working File\Board Admin Code 2005-2006\Conflict of Interest 1.02.020.docx~~\\Approved 8-3-05 by Ordinance No. 05-07\\Amended and Updated 7-21-06 by Resolution No. 06-10\\Approved 11-17-06 by Ordinance No. 06-09\\Amended and Updated 8-26-08 by Resolution No. 08-10\\Approved 10-28-08 by Ordinance No. 08-11\\Amended and Updated 06-26-12 by Ordinance No. 12-02\\Amended and Updated 4-23-13 by Ordinance No. 13-04\\Amended and Updated 4-22-14 by Ordinance No. 14-02\\Amended and Updated 8-26-14 by Ordinance No. 14-06\\Amended and Updated 2-24-15 by Ordinance No. 15-04\\Amended and Updated 1-26-16 by Ordinance No. 16-02\\Amended and Updated 3-22-16 by Ordinance No. 16-04\\Amended and Updated 1-23-18 by Ordinance No. 18-02\\Amended and Updated 3-27-18 by Ordinance No. 18-05\\**DRAFT**

**Appendix A**  
**Rainbow Municipal Water District Conflict of Interest Code**

**Preamble**

Any person designated in Section I of this Appendix who is unsure of any right or obligation arising under this Code may request a formal opinion or letter of advice from the FPPC or an opinion from Rainbow Municipal Water District's General Counsel. (Gov. Code § 83114; 2 CCR § 18730(b)(11).) A person who acts in good faith in reliance on an opinion issued to him or her by the FPPC shall not be subject to criminal or civil penalties for so acting, provided that all material facts are stated in the opinion request. (Gov. Code § 83114(a).)

Opinions rendered by General Counsel do not provide any statutory defense to an alleged violation of conflict of interest statutes or regulations. The prosecuting agency may, but is not required to, consider a requesting party's reliance on General Counsel's opinion as evidence of good faith. In addition, Rainbow Municipal Water District may consider whether such reliance should constitute a mitigating factor to any disciplinary action that Rainbow Municipal Water District may bring against the requesting party under Government Code section 91003.5.

~~\\rmwd-b\Store02\DriveC\Data\Drive-E\ADMINISTRATIVE CODE\Drafts Not Approved\Conflict of Interest 1.02.020.docx~~~~\\rmwd-b\Store03\BoardFiles\Board Secretary\Administrative Code Working File\Board Admin Code 2005-2006\Conflict of Interest 1.02.020.docx~~Approved 8-3-05 by Ordinance No. 05-07\\Amended and Updated 7-21-06 by Resolution No. 06-10\\Approved 11-17-06 by Ordinance No. 06-09\\Amended and Updated 8-26-08 by Resolution No. 08-10\\Approved 10-28-08 by Ordinance No. 08-11\\Amended and Updated 06-26-12 by Ordinance No. 12-02\\Amended and Updated 4-23-13 by Ordinance No. 13-04\\Amended and Updated 4-22-14 by Ordinance No. 14-02\\Amended and Updated 8-26-14 by Ordinance No. 14-06\\Amended and Updated 2-24-15 by Ordinance No. 15-04\\Amended and Updated 1-26-16 by Ordinance No. 16-02\\Amended and Updated 3-22-16 by Ordinance No. 16-04\\Amended and Updated 1-23-18 by Ordinance No. 18-02\\Amended and Updated 3-27-18 by Ordinance No. 18-05\\**DRAFT**



## Part I - Designated Positions

<u>Designated Employees</u>	<u>Categories Disclosed</u>
Members of the Board of Directors	All
General Manager	All
General Counsel	All
District Engineer	All
Operations Manager	All
Human Resources Manager	All
Construction/Maintenance Superintendent	All
Water Operations Superintendent	All
Wastewater Superintendent	All
Associate Engineer	All
Purchasing & Inventory Control Specialist I/II	All
Environmental Health and Safety Officer	All
Engineering Inspector I/II	All

~~\\rmwd-b)\Store02\DriveC\Data\Drive-E\ADMINISTRATIVE\_CODE\Drafts Not Approved\Conflict of Interest 1.02.020.docx~~~~\\rmwd-b)\Store03\BoardFiles\Board Secretary\Administrative Code Working File\Board Admin Code 2005-2006\Conflict of Interest 1.02.020.docx~~ Approved 8-3-05 by Ordinance No. 05-07\Amended and Updated 7-21-06 by Resolution No. 06-10\Approved 11-17-06 by Ordinance No. 06-09\Amended and Updated 8-26-08 by Resolution No. 08-10\Approved 10-28-08 by Ordinance No. 08-11\Amended and Updated 06-26-12 by Ordinance No. 12-02\Amended and Updated 4-23-13 by Ordinance No. 13-04\Amended and Updated 4-22-14 by Ordinance No. 14-02\Amended and Updated 8-26-14 by Ordinance No. 14-06\Amended and Updated 2-24-15 by Ordinance No. 15-04\Amended and Updated 1-26-16 by Ordinance No. 16-02\Amended and Updated 3-22-16 by Ordinance No. 16-04\Amended and Updated 1-23-18 by Ordinance No. 18-02\Amended and Updated 3-27-18 by Ordinance No. 18-05\ **DRAFT**

Water Quality Technician I/II	All
Information Technology and Applications Analyst and Senior Information Technology and Applications Analyst	All
Right-of-Way and Facilities Coordinator	All
<sup>1</sup> Consultants	2

### Part II – Non-Designated Positions

Finance Manager	Pursuant to Applicable Laws
Standing District Committee Members	2
Auditor	2

---

<sup>1</sup> With respect to consultants, the General Manager may determine in writing that a particular consultant, although a “designated employee,” is hired to perform a range of duties that is limited in scope and thus is not required to comply with the written disclosure requirements described in these categories. Such written determination shall include a description of the consultant's duties and, based upon that description, a statement of the extent of disclosure requirements. The General Manager’s determination is a public record and shall be retained for public inspection by Rainbow Municipal Water District in the same manner as this Conflict of Interest Code. Nothing herein excuses any such consultant from any other provision of this Conflict of Interest Code.

~~\\rmwd-b\Store02\DriveC\Data\Drive-E\ADMINISTRATIVE\_CODE\Drafts Not Approved\Conflict of Interest 1.02.020.docx~~~~\\rmwd-b\Store03\BoardFiles\Board Secretary\Administrative Code Working File\Board Admin Code 2005-2006\Conflict of Interest 1.02.020.docx~~ Approved 8-3-05 by Ordinance No. 05-07\Amended and Updated 7-21-06 by Resolution No. 06-10\Approved 11-17-06 by Ordinance No. 06-09\Amended and Updated 8-26-08 by Resolution No. 08-10\Approved 10-28-08 by Ordinance No. 08-11\Amended and Updated 06-26-12 by Ordinance No. 12-02\Amended and Updated 4-23-13 by Ordinance No. 13-04\Amended and Updated 4-22-14 by Ordinance No. 14-02\Amended and Updated 8-26-14 by Ordinance No. 14-06\Amended and Updated 2-24-15 by Ordinance No. 15-04\Amended and Updated 1-26-16 by Ordinance No. 16-02\Amended and Updated 3-22-16 by Ordinance No. 16-04\Amended and Updated 1-23-18 by Ordinance No. 18-02\Amended and Updated 3-27-18 by Ordinance No. 18-05\ **DRAFT**

## Part II - Disclosure Categories

### Category 1.

A designated employee or person in this category shall report all interests in real property, and investments in, and income from, business entities of the type to operate or provide any of the following:

- Accounting or auditing services
- Banks and savings and loans
- Computer hardware or software, or computer services or consultants
- Communications equipment or services
- Insurance brokers and agencies
- Insurance adjusting, claims auditing or administration, or underwriting services
- Office equipment or supplies
- Personnel and employment companies and services
- Printing or reproduction services, publications, and distribution
- Securities, investment or financial services companies
- Title insurance and escrow
- Construction supplies, service or equipment
- Engineering and surveying services
- Land development services

### Category 2.

A designated employee in this category shall disclose all business positions in, investments in, and income from any business of the type to provide personnel, services, supplies, material, machinery, or equipment to Rainbow Municipal Water District and is associated with the job assignment or position of the designated employee or person.

~~\\rmwd-b\Store02\DriveC\Data\Drive-E\ADMINISTRATIVE\_CODE\Drafts Not Approved\Conflict of Interest 1.02.020.docx~~  
~~\\rmwd-b\Store03\BoardFiles\Board Secretary\Administrative Code Working File\Board Admin Code 2005-2006\Conflict of Interest 1.02.020.docx~~  
Approved 8-3-05 by Ordinance No. 05-07\\Amended and Updated 7-21-06 by Resolution No. 06-10\\Approved 11-17-06 by Ordinance No. 06-09\\Amended and Updated 8-26-08 by Resolution No. 08-10\\Approved 10-28-08 by Ordinance No. 08-11\\Amended and Updated 06-26-12 by Ordinance No. 12-02\\Amended and Updated 4-23-13 by Ordinance No. 13-04\\Amended and Updated 4-22-14 by Ordinance No. 14-02\\Amended and Updated 8-26-14 by Ordinance No. 14-06\\Amended and Updated 2-24-15 by Ordinance No. 15-04\\Amended and Updated 1-26-16 by Ordinance No. 16-02\\Amended and Updated 3-22-16 by Ordinance No. 16-04\\Amended and Updated 1-23-18 by Ordinance No. 18-02\\Amended and Updated 3-27-18 by Ordinance No. 18-05\\**DRAFT**

**Appendix B**  
**Statement of Duties of Employees of**  
**and Consultants to Rainbow Municipal Water District**

Members of the Board of Directors

The Board of Directors acts as the Rainbow Municipal Water District's governing body. Members of the Board of Directors formulate general policy and programs of Rainbow Municipal Water District, and each member of the Board of Directors therefore is designated.

General Manager

General Manager oversees the day-to-day operations of Rainbow Municipal Water District. He or she participates in the formulation and implementation of the policies and programs of Rainbow Municipal Water District and therefore is designated.

General Counsel

General Counsel, currently hired on a contract basis, advises Rainbow Municipal Water District on its day-to-day activities, including its relationships with the independent contractors who serve in a staff capacity to Rainbow Municipal Water District, and compliance with applicable laws and regulations. He or she participates in the formulation and implementation of the policies and programs of Rainbow Municipal Water District and therefore is designated.

Financial Manager

An employee of the Rainbow Municipal Water District, the Financial Manager is Rainbow Municipal Water District's Chief Financial Officer and helps manage the finances of Rainbow Municipal Water District. The Financial Manager makes reports from time to time on the financial results of operations of Rainbow Municipal Water District, and recommends fiscal policies to the Board of Directors. The Financial Manager "manages public investments" within the meaning of applicable regulations. He or she therefore is not designated.

District Engineer

The District Engineer provides engineering services and oversight to Rainbow Municipal Water District, including implementation of capital replacement projects. He or she participates in the formulation of Rainbow Municipal Water District's general policies and programs in the area of engineering and is therefore designated.

Operations Manager

An employee of Rainbow Municipal Water District, the Operations Manager oversees the operation and maintenance of the water and wastewater lines and structures; risk management; and

~~\\rmwd-b\Store02\DriveC\Data\Drive-E\ADMINISTRATIVE\_CODE\Drafts Not Approved\Conflict of Interest 1.02.020.docx~~~~\\rmwd-b\Store03\BoardFiles\Board Secretary\Administrative Code Working File\Board Admin Code 2005-2006\Conflict of Interest 1.02.020.docx~~\\Approved 8-3-05 by Ordinance No. 05-07\\Amended and Updated 7-21-06 by Resolution No. 06-10\\Approved 11-17-06 by Ordinance No. 06-09\\Amended and Updated 8-26-08 by Resolution No. 08-10\\Approved 10-28-08 by Ordinance No. 08-11\\Amended and Updated 06-26-12 by Ordinance No. 12-02\\Amended and Updated 4-23-13 by Ordinance No. 13-04\\Amended and Updated 4-22-14 by Ordinance No. 14-02\\Amended and Updated 8-26-14 by Ordinance No. 14-06\\Amended and Updated 2-24-15 by Ordinance No. 15-04\\Amended and Updated 1-26-16 by Ordinance No. 16-02\\Amended and Updated 3-22-16 by Ordinance No. 16-04\\Amended and Updated 1-23-18 by Ordinance No. 18-02\\Amended and Updated 3-27-18 by Ordinance No. 18-05\\DRAFT

employee safety. He or she participates in the formulation of Rainbow Municipal Water District's general policies and programs in the area of operations and maintenance and is therefore designated.

#### Human Resources Manager

The Human Resources Manager plans, directs and oversees the following programs and activities: human resources; labor relations; workers' compensation, property and liability insurance and is therefore designated.

#### Construction/Maintenance Superintendent

The Construction/Maintenance Superintendent has managerial responsibilities to direct and oversee the Construction and Valve Maintenance and Fleet Divisions. This position coordinates and manages the installation, maintenance and repair of water mains, service lines, fire hydrants, valves, pressure regulating stations, pumps, motors and other related appurtenances used in the District water distribution, treatment and storage facilities and fleet maintenance and repair and is therefore designated.

#### Water Operations Superintendent

The Water Operations Superintendent has managerial responsibilities to direct and oversee the Water Operations Division, the electrical program and the Supervisory Control and Data Acquisition (SCADA) and telemetry systems. This position will coordinate and manage the installation, maintenance, repair and operation of District water distribution, treatment, pumping and storage facilities and electrical, electronic and telemetry repair and maintenance and is therefore designated.

#### Wastewater Superintendent

The Wastewater Superintendent has managerial responsibility to direct and oversee the Wastewater Division. This position coordinates and manages the repair, maintenance and operation of the wastewater pumping and collection system as well as may assist with installation, maintenance and repair of water distribution facilities and is therefore designated.

#### Associate Engineer

The Associate Engineer performs a variety of routine and semi-routine professional level civil engineering work in the research, design and construction of water and sewer capital improvement and construction projects as well as reviews development plans and is therefore designated.

#### Purchasing & Inventory Control Specialist I/II

The Purchasing & Inventory Control Specialist I/II has responsibility for all functions associated with the warehouse including purchasing, receiving and inventory control and administration of the office cleaning contract as well as maintaining inventory of parts and supplies and is therefore designated.

#### Environmental Health & Safety Officer

~~\\rmwd-b\Store02\DriveC\Data\Drive-E\ADMINISTRATIVE\_CODE\Drafts Not Approved\Conflict of Interest 1.02.020.docx~~~~\\rmwd-b\Store03\BoardFiles\Board Secretary\Administrative Code Working File\Board Admin Code 2005-2006\Conflict of Interest 1.02.020.docx~~ Approved 8-3-05 by Ordinance No. 05-07\Amended and Updated 7-21-06 by Resolution No. 06-10\Approved 11-17-06 by Ordinance No. 06-09\Amended and Updated 8-26-08 by Resolution No. 08-10\Approved 10-28-08 by Ordinance No. 08-11\Amended and Updated 06-26-12 by Ordinance No. 12-02\Amended and Updated 4-23-13 by Ordinance No. 13-04\Amended and Updated 4-22-14 by Ordinance No. 14-02\Amended and Updated 8-26-14 by Ordinance No. 14-06\Amended and Updated 2-24-15 by Ordinance No. 15-04\Amended and Updated 1-26-16 by Ordinance No. 16-02\Amended and Updated 3-22-16 by Ordinance No. 16-04\Amended and Updated 1-23-18 by Ordinance No. 18-02\Amended and Updated 3-27-18 by Ordinance No. 18-05\ **DRAFT**

The Environmental Health & Safety Officer has responsibility for the planning and administration of the District programs and services related to safety, security, emergency preparedness and environmental compliance functions and is therefore designated.

~~\\rmwd-b\Store02\DriveC\Data\Drive-E\ADMINISTRATIVE CODE\Drafts Not Approved\Conflict of Interest 1.02.020.docx~~~~\\rmwd-b\Store03\BoardFiles\Board Secretary\Administrative Code Working File\Board Admin Code 2005-2006\Conflict of Interest 1.02.020.docx~~Approved 8-3-05 by Ordinance No. 05-07\\Amended and Updated 7-21-06 by Resolution No. 06-10\\Approved 11-17-06 by Ordinance No. 06-09\\Amended and Updated 8-26-08 by Resolution No. 08-10\\Approved 10-28-08 by Ordinance No. 08-11\\Amended and Updated 06-26-12 by Ordinance No. 12-02\\Amended and Updated 4-23-13 by Ordinance No. 13-04\\Amended and Updated 4-22-14 by Ordinance No. 14-02\\Amended and Updated 8-26-14 by Ordinance No. 14-06\\Amended and Updated 2-24-15 by Ordinance No. 15-04\\Amended and Updated 1-26-16 by Ordinance No. 16-02\\Amended and Updated 3-22-16 by Ordinance No. 16-04\\Amended and Updated 1-23-18 by Ordinance No. 18-02\\Amended and Updated 3-27-18 by Ordinance No. 18-05\\**DRAFT**

### Engineering Inspector I/II

Under supervision of the District Engineer, the Engineering Inspector I/II performs highly specialized and complex public works construction inspection work. This position acts as the District's representative on the construction site for the expressed intent of enforcement of District construction standards and regulations and is therefore designated.

### Water Quality Technician I/II

The Water Quality Technician I/II performs a wide variety of professional, analytical and technical water quality functions involved in the District's water treatment and distribution system; interprets water quality test results and prepares reports; performs tasks related to quality assurance; ensure compliance with permit requirements, ordinances and federal and state regulations regarding potable water and is therefore designated.

### Information Technology and Applications Analyst /Senior IT and Applications Analyst

The Senior Information Technology and Applications Analyst/Senior Information and Applications Analyst position monitors, maintains, troubleshoots, and diagnoses hardware, software, database and network problems and identifies courses of action. This position also supervises the purchasing, inventorying, maintenance and the disposing of computing and communication devices, hardware and software and is therefore designated.

### Right-of-Way and Facilities Coordinator

The Right-of-Way and Facilities Coordinator is responsible for monitoring and resolving right-of-way issues related to acquisitions, vegetation clearing, and encroachments. This position also coordinates all facilities maintenance, including selecting service providers and vendors for landscaping, building and grounds maintenance, and is therefore designated.

### Auditor

Rainbow Municipal Water District has contracted with one or more accounting firms to handle financial audits of Rainbow Municipal Water District's finances and investments. These firms implement decisions of the Rainbow Municipal Water District's Board of Directors. Because these auditors' duties are restricted in the manner described herein, they do not participate in the formulation and implementation of the policies and programs of Rainbow Municipal Water District, and also do not "manage public investments" within the meaning of applicable regulations; therefore, the Auditor(s). ~~Therefore, standing district committee members~~ shall be considered non-designated positions and will file Statements of Economic Interest forms with the District only for public review and information purposes.

~~\\rmwd-b\Store02\DriveC\Data\Drive-E\ADMINISTRATIVE\_CODE\Drafts Not Approved\Conflict of Interest 1.02.020.docx~~~~\\rmwd-b\Store03\BoardFiles\Board Secretary\Administrative Code Working File\Board Admin Code 2005-2006\Conflict of Interest 1.02.020.docx~~Approved 8-3-05 by Ordinance No. 05-07\\Amended and Updated 7-21-06 by Resolution No. 06-10\\Approved 11-17-06 by Ordinance No. 06-09\\Amended and Updated 8-26-08 by Resolution No. 08-10\\Approved 10-28-08 by Ordinance No. 08-11\\Amended and Updated 06-26-12 by Ordinance No. 12-02\\Amended and Updated 4-23-13 by Ordinance No. 13-04\\Amended and Updated 4-22-14 by Ordinance No. 14-02\\Amended and Updated 8-26-14 by Ordinance No. 14-06\\Amended and Updated 2-24-15 by Ordinance No. 15-04\\Amended and Updated 1-26-16 by Ordinance No. 16-02\\Amended and Updated 3-22-16 by Ordinance No. 16-04\\Amended and Updated 1-23-18 by Ordinance No. 18-02\\Amended and Updated 3-27-18 by Ordinance No. 18-05\\DRAFT

## Standing District Committee Members

A member or alternate committee member of a Rainbow Municipal Water District standing committee serves at the pleasure of the Board. These committees are advisory to the Board with regard to matters within their respective areas of responsibility. A committee has jurisdiction to consider and make a recommendation to other committees and to the Board regarding any item of business within the responsibility of the committee. Committee recommendations shall be communicated to the Board. A committee may consider other matters referred to it by the Board. Therefore, standing district committee members shall be considered non-designated positions and will file Statements of Economic Interest forms with the District only for public review and information purposes.

\\rmwd-b\Store02\DriveC\Data\Drive-E\ADMINISTRATIVE CODE\Drafts Not Approved\Conflict of Interest 1.02.020.docx~~\\rmwd-b\Store03\BoardFiles\Board Secretary\Administrative Code Working File\Board Admin Code 2005-2006\Conflict of Interest 1.02.020.docx~~\\Approved 8-3-05 by Ordinance No. 05-07\\Amended and Updated 7-21-06 by Resolution No. 06-10\\Approved 11-17-06 by Ordinance No. 06-09\\Amended and Updated 8-26-08 by Resolution No. 08-10\\Approved 10-28-08 by Ordinance No. 08-11\\Amended and Updated 06-26-12 by Ordinance No. 12-02\\Amended and Updated 4-23-13 by Ordinance No. 13-04\\Amended and Updated 4-22-14 by Ordinance No. 14-02\\Amended and Updated 8-26-14 by Ordinance No. 14-06\\Amended and Updated 2-24-15 by Ordinance No. 15-04\\Amended and Updated 1-26-16 by Ordinance No. 16-02\\Amended and Updated 3-22-16 by Ordinance No. 16-04\\Amended and Updated 1-23-18 by Ordinance No. 18-02\\Amended and Updated 3-27-18 by Ordinance No. 18-05\\**DRAFT**



**Section 1.02.020**  
**Conflict of Interest**

**1.02.020.01** The Political Reform Act (Government Code Section 81000, et seq.) requires state and local government agencies to adopt and promulgate conflict of interest codes. The Fair Political Practices Commission has adopted a regulation (2 Cal. Code Regs. Section 18730) that contains the terms of a standard conflict of interest code and may be incorporated by reference in any agency's code. After public notice and hearing, the standard code may be amended by the Fair Political Practices Commission to conform to amendments in the Political Reform Act.

**1.02.020.02** Therefore, the terms of 2 California Code of **Regulations Section 18730** and any amendments to it duly adopted by the Fair Political Practices Commission are hereby incorporated by reference. This regulation and the attached Appendix designating positions, and establishing disclosure requirements, shall constitute the conflict of interest code of the Rainbow Municipal Water District.

**1.02.020.03** Individuals holding designated and non-designated positions shall file their Statements of Economic Interest with Rainbow Municipal Water District, which will make the statements available for public inspection and reproduction. (Gov. Code Section 81008.) Upon receipt of the statements for the Board Members and General Manager, the Board Secretary shall make and retain copies and forward the originals of these statements to the County Board of Supervisors. Statements for all other designated employees shall be retained by Rainbow Municipal Water District.

Any public officials who manage public investments shall be considered non-designated positions under Government Code section 87200 and shall make the disclosures required by law. Originals of all Statements of Economic Interest filed by non-designated positions will be maintained at the District office.

\\rmwd-b\Store02\DriveC\Data\Drive-E\ADMINISTRATIVE CODE\Drafts\_Not Approved\Conflict of Interest 1.02.020.docx\Approved 8-3-05 by Ordinance No. 05-07\Amended and Updated 7-21-06 by Resolution No. 06-10\Approved 11-17-06 by Ordinance No. 06-09\Amended and Updated 8-26-08 by Resolution No. 08-10\Approved 10-28-08 by Ordinance No. 08-11\Amended and Updated 06-26-12 by Ordinance No. 12-02\Amended and Updated 4-23-13 by Ordinance No. 13-04\Amended and Updated 4-22-14 by Ordinance No. 14-02\Amended and Updated 8-26-14 by Ordinance No. 14-06\Amended and Updated 2-24-15 by Ordinance No. 15-04\Amended and Updated 1-26-16 by Ordinance No. 16-02\Amended and Updated 3-22-16 by Ordinance No. 16-04\Amended and Updated 1-23-18 by Ordinance No. 18-02\Amended and Updated 3-27-18 by Ordinance No. 18-05\DRAFT

**Appendix A**  
**Rainbow Municipal Water District Conflict of Interest Code**

**Preamble**

Any person designated in Section I of this Appendix who is unsure of any right or obligation arising under this Code may request a formal opinion or letter of advice from the FPPC or an opinion from Rainbow Municipal Water District's General Counsel. (Gov. Code § 83114; 2 CCR § 18730(b)(11).) A person who acts in good faith in reliance on an opinion issued to him or her by the FPPC shall not be subject to criminal or civil penalties for so acting, provided that all material facts are stated in the opinion request. (Gov. Code § 83114(a).)

Opinions rendered by General Counsel do not provide any statutory defense to an alleged violation of conflict of interest statutes or regulations. The prosecuting agency may, but is not required to, consider a requesting party's reliance on General Counsel's opinion as evidence of good faith. In addition, Rainbow Municipal Water District may consider whether such reliance should constitute a mitigating factor to any disciplinary action that Rainbow Municipal Water District may bring against the requesting party under Government Code section 91003.5.

\\rmwd-b\Store02\DriveC\Data\Drive-E\ADMINISTRATIVE CODE\Drafts\_Not Approved\Conflict of Interest 1.02.020.docx\\Approved 8-3-05 by Ordinance No. 05-07\\Amended and Updated 7-21-06 by Resolution No. 06-10\\Approved 11-17-06 by Ordinance No. 06-09\\Amended and Updated 8-26-08 by Resolution No. 08-10\\Approved 10-28-08 by Ordinance No. 08-11\\Amended and Updated 06-26-12 by Ordinance No. 12-02\\Amended and Updated 4-23-13 by Ordinance No. 13-04\\Amended and Updated 4-22-14 by Ordinance No. 14-02\\Amended and Updated 8-26-14 by Ordinance No. 14-06\\Amended and Updated 2-24-15 by Ordinance No. 15-04\\Amended and Updated 1-26-16 by Ordinance No. 16-02\\Amended and Updated 3-22-16 by Ordinance No. 16-04\\Amended and Updated 1-23-18 by Ordinance No. 18-02\\Amended and Updated 3-27-18 by Ordinance No. 18-05\\DRAFT

## Part I - Designated Positions

<u>Designated Employees</u>	<u>Categories Disclosed</u>
Members of the Board of Directors	All
General Manager	All
General Counsel	All
District Engineer	All
Operations Manager	All
Human Resources Manager	All
Construction/Maintenance Superintendent	All
Water Operations Superintendent	All
Wastewater Superintendent	All
Associate Engineer	All
Purchasing & Inventory Control Specialist I/II	All
Environmental Health and Safety Officer	All
Engineering Inspector I/II	All

\\rmwd-b\Store02\DriveC\Data\Drive-E\ADMINISTRATIVE CODE\Drafts\_Not Approved\Conflict of Interest 1.02.020.docx\Approved 8-3-05 by Ordinance No. 05-07\Amended and Updated 7-21-06 by Resolution No. 06-10\Approved 11-17-06 by Ordinance No. 06-09\Amended and Updated 8-26-08 by Resolution No. 08-10\Approved 10-28-08 by Ordinance No. 08-11\Amended and Updated 06-26-12 by Ordinance No. 12-02\Amended and Updated 4-23-13 by Ordinance No. 13-04\Amended and Updated 4-22-14 by Ordinance No. 14-02\Amended and Updated 8-26-14 by Ordinance No. 14-06\Amended and Updated 2-24-15 by Ordinance No. 15-04\Amended and Updated 1-26-16 by Ordinance No. 16-02\Amended and Updated 3-22-16 by Ordinance No. 16-04\Amended and Updated 1-23-18 by Ordinance No. 18-02\Amended and Updated 3-27-18 by Ordinance No. 18-05\DRAFT

Water Quality Technician I/II	All
Information Technology and Applications Analyst and Senior Information Technology and Applications Analyst	All
Right-of-Way and Facilities Coordinator	All
<sup>1</sup> Consultants	2

**Part II – Non-Designated Positions**

Finance Manager	Pursuant to Applicable Laws
Standing District Committee Members	2
Auditor	2

---

<sup>1</sup> With respect to consultants, the General Manager may determine in writing that a particular consultant, although a “designated employee,” is hired to perform a range of duties that is limited in scope and thus is not required to comply with the written disclosure requirements described in these categories. Such written determination shall include a description of the consultant's duties and, based upon that description, a statement of the extent of disclosure requirements. The General Manager’s determination is a public record and shall be retained for public inspection by Rainbow Municipal Water District in the same manner as this Conflict of Interest Code. Nothing herein excuses any such consultant from any other provision of this Conflict of Interest Code.

\\rmwd-b\Store02\DriveC\Data\Drive-E\ADMINISTRATIVE CODE\Drafts\_Not Approved\Conflict of Interest 1.02.020.docx\Approved 8-3-05 by Ordinance No. 05-07\Amended and Updated 7-21-06 by Resolution No. 06-10\Approved 11-17-06 by Ordinance No. 06-09\Amended and Updated 8-26-08 by Resolution No. 08-10\Approved 10-28-08 by Ordinance No. 08-11\Amended and Updated 06-26-12 by Ordinance No. 12-02\Amended and Updated 4-23-13 by Ordinance No. 13-04\Amended and Updated 4-22-14 by Ordinance No. 14-02\Amended and Updated 8-26-14 by Ordinance No. 14-06\Amended and Updated 2-24-15 by Ordinance No. 15-04\Amended and Updated 1-26-16 by Ordinance No. 16-02\Amended and Updated 3-22-16 by Ordinance No. 16-04\Amended and Updated 1-23-18 by Ordinance No. 18-02\Amended and Updated 3-27-18 by Ordinance No. 18-05\DRAFT

## Part II - Disclosure Categories

### Category 1.

A designated employee or person in this category shall report all interests in real property, and investments in, and income from, business entities of the type to operate or provide any of the following:

- Accounting or auditing services
- Banks and savings and loans
- Computer hardware or software, or computer services or consultants
- Communications equipment or services
- Insurance brokers and agencies
- Insurance adjusting, claims auditing or administration, or underwriting services
- Office equipment or supplies
- Personnel and employment companies and services
- Printing or reproduction services, publications, and distribution
- Securities, investment or financial services companies
- Title insurance and escrow
- Construction supplies, service or equipment
- Engineering and surveying services
- Land development services

### Category 2.

A designated employee in this category shall disclose all business positions in, investments in, and income from any business of the type to provide personnel, services, supplies, material, machinery, or equipment to Rainbow Municipal Water District and is associated with the job assignment or position of the designated employee or person.

\\rmwd-b\Store02\DriveC\Data\Drive-E\ADMINISTRATIVE CODE\Drafts\_Not Approved\Conflict of Interest 1.02.020.docx\Approved 8-3-05 by Ordinance No. 05-07\Amended and Updated 7-21-06 by Resolution No. 06-10\Approved 11-17-06 by Ordinance No. 06-09\Amended and Updated 8-26-08 by Resolution No. 08-10\Approved 10-28-08 by Ordinance No. 08-11\Amended and Updated 06-26-12 by Ordinance No. 12-02\Amended and Updated 4-23-13 by Ordinance No. 13-04\Amended and Updated 4-22-14 by Ordinance No. 14-02\Amended and Updated 8-26-14 by Ordinance No. 14-06\Amended and Updated 2-24-15 by Ordinance No. 15-04\Amended and Updated 1-26-16 by Ordinance No. 16-02\Amended and Updated 3-22-16 by Ordinance No. 16-04\Amended and Updated 1-23-18 by Ordinance No. 18-02\Amended and Updated 3-27-18 by Ordinance No. 18-05\DRAFT

**Appendix B  
Statement of Duties of Employees of  
and Consultants to Rainbow Municipal Water District**

Members of the Board of Directors

The Board of Directors acts as the Rainbow Municipal Water District's governing body. Members of the Board of Directors formulate general policy and programs of Rainbow Municipal Water District, and each member of the Board of Directors therefore is designated.

General Manager

General Manager oversees the day-to-day operations of Rainbow Municipal Water District. He or she participates in the formulation and implementation of the policies and programs of Rainbow Municipal Water District and therefore is designated.

General Counsel

General Counsel, currently hired on a contract basis, advises Rainbow Municipal Water District on its day-to-day activities, including its relationships with the independent contractors who serve in a staff capacity to Rainbow Municipal Water District, and compliance with applicable laws and regulations. He or she participates in the formulation and implementation of the policies and programs of Rainbow Municipal Water District and therefore is designated.

Financial Manager

An employee of the Rainbow Municipal Water District, the Financial Manager is Rainbow Municipal Water District's Chief Financial Officer and helps manage the finances of Rainbow Municipal Water District. The Financial Manager makes reports from time to time on the financial results of operations of Rainbow Municipal Water District, and recommends fiscal policies to the Board of Directors. The Financial Manager "manages public investments" within the meaning of applicable regulations. He or she therefore is not designated.

District Engineer

The District Engineer provides engineering services and oversight to Rainbow Municipal Water District, including implementation of capital replacement projects. He or she participates in the formulation of Rainbow Municipal Water District's general policies and programs in the area of engineering and is therefore designated.

Operations Manager

An employee of Rainbow Municipal Water District, the Operations Manager oversees the operation and maintenance of the water and wastewater lines and structures; risk management; and employee safety. He or she participates in the formulation of Rainbow Municipal Water District's general policies and programs in the area of operations and maintenance and is therefore designated.

\\rmwd-b\Store02\DriveC\Data\Drive-E\ADMINISTRATIVE CODE\Drafts\_Not Approved\Conflict of Interest 1.02.020.docx\Approved 8-3-05 by Ordinance No. 05-07\Amended and Updated 7-21-06 by Resolution No. 06-10\Approved 11-17-06 by Ordinance No. 06-09\Amended and Updated 8-26-08 by Resolution No. 08-10\Approved 10-28-08 by Ordinance No. 08-11\Amended and Updated 06-26-12 by Ordinance No. 12-02\Amended and Updated 4-23-13 by Ordinance No. 13-04\Amended and Updated 4-22-14 by Ordinance No. 14-02\Amended and Updated 8-26-14 by Ordinance No. 14-06\Amended and Updated 2-24-15 by Ordinance No. 15-04\Amended and Updated 1-26-16 by Ordinance No. 16-02\Amended and Updated 3-22-16 by Ordinance No. 16-04\Amended and Updated 1-23-18 by Ordinance No. 18-02\Amended and Updated 3-27-18 by Ordinance No. 18-05\DRAFT

### Human Resources Manager

The Human Resources Manager plans, directs and oversees the following programs and activities: human resources; labor relations; workers' compensation, property and liability insurance and is therefore designated.

### Construction/Maintenance Superintendent

The Construction/Maintenance Superintendent has managerial responsibilities to direct and oversee the Construction and Valve Maintenance and Fleet Divisions. This position coordinates and manages the installation, maintenance and repair of water mains, service lines, fire hydrants, valves, pressure regulating stations, pumps, motors and other related appurtenances used in the District water distribution, treatment and storage facilities and fleet maintenance and repair and is therefore designated.

### Water Operations Superintendent

The Water Operations Superintendent has managerial responsibilities to direct and oversee the Water Operations Division, the electrical program and the Supervisory Control and Data Acquisition (SCADA) and telemetry systems. This position will coordinate and manage the installation, maintenance, repair and operation of District water distribution, treatment, pumping and storage facilities and electrical, electronic and telemetry repair and maintenance and is therefore designated.

### Wastewater Superintendent

The Wastewater Superintendent has managerial responsibility to direct and oversee the Wastewater Division. This position coordinates and manages the repair, maintenance and operation of the wastewater pumping and collection system as well as may assist with installation, maintenance and repair of water distribution facilities and is therefore designated.

### Associate Engineer

The Associate Engineer performs a variety of routine and semi-routine professional level civil engineering work in the research, design and construction of water and sewer capital improvement and construction projects as well as reviews development plans and is therefore designated.

### Purchasing & Inventory Control Specialist I/II

The Purchasing & Inventory Control Specialist I/II has responsibility for all functions associated with the warehouse including purchasing, receiving and inventory control and administration of the office cleaning contract as well as maintaining inventory of parts and supplies and is therefore designated.

### Environmental Health & Safety Officer

The Environmental Health & Safety Officer has responsibility for the planning and administration of the District programs and services related to safety, security, emergency preparedness and environmental compliance functions and is therefore designated.

\\rmwd-b\Store02\DriveC\Data\Drive-E\ADMINISTRATIVE CODE\Drafts\_Not Approved\Conflict of Interest 1.02.020.docx\Approved 8-3-05 by Ordinance No. 05-07\Amended and Updated 7-21-06 by Resolution No. 06-10\Approved 11-17-06 by Ordinance No. 06-09\Amended and Updated 8-26-08 by Resolution No. 08-10\Approved 10-28-08 by Ordinance No. 08-11\Amended and Updated 06-26-12 by Ordinance No. 12-02\Amended and Updated 4-23-13 by Ordinance No. 13-04\Amended and Updated 4-22-14 by Ordinance No. 14-02\Amended and Updated 8-26-14 by Ordinance No. 14-06\Amended and Updated 2-24-15 by Ordinance No. 15-04\Amended and Updated 1-26-16 by Ordinance No. 16-02\Amended and Updated 3-22-16 by Ordinance No. 16-04\Amended and Updated 1-23-18 by Ordinance No. 18-02\Amended and Updated 3-27-18 by Ordinance No. 18-05\DRAFT

### Engineering Inspector I/II

Under supervision of the District Engineer, the Engineering Inspector I/II performs highly specialized and complex public works construction inspection work. This position acts as the District's representative on the construction site for the expressed intent of enforcement of District construction standards and regulations and is therefore designated.

### Water Quality Technician I/II

The Water Quality Technician I/II performs a wide variety of professional, analytical and technical water quality functions involved in the District's water treatment and distribution system; interprets water quality test results and prepares reports; performs tasks related to quality assurance; ensure compliance with permit requirements, ordinances and federal and state regulations regarding potable water and is therefore designated.

### Information Technology and Applications Analyst /Senior IT and Applications Analyst

The Senior Information Technology and Applications Analyst/Senior Information and Applications Analyst position monitors, maintains, troubleshoots, and diagnoses hardware, software, database and network problems and identifies courses of action. This position also supervises the purchasing, inventorying, maintenance and the disposing of computing and communication devices, hardware and software and is therefore designated.

### Right-of-Way and Facilities Coordinator

The Right-of-Way and Facilities Coordinator is responsible for monitoring and resolving right-of-way issues related to acquisitions, vegetation clearing, and encroachments. This position also coordinates all facilities maintenance, including selecting service providers and vendors for landscaping, building and grounds maintenance, and is therefore designated.

### Auditor

Rainbow Municipal Water District has contracted with one or more accounting firms to handle financial audits of Rainbow Municipal Water District's finances and investments. These firms implement decisions of the Rainbow Municipal Water District's Board of Directors. Because these auditors' duties are restricted in the manner described herein, they do not participate in the formulation and implementation of the policies and programs of Rainbow Municipal Water District, and also do not "manage public investments" within the meaning of applicable regulations; therefore, the Auditor(s) shall be considered non-designated positions and will file Statements of Economic Interest forms with the District only for public review and information purposes.

\\rmwd-b\Store02\DriveC\Data\Drive-E\ADMINISTRATIVE CODE\Drafts\_Not Approved\Conflict of Interest 1.02.020.docx\Approved 8-3-05 by Ordinance No. 05-07\Amended and Updated 7-21-06 by Resolution No. 06-10\Approved 11-17-06 by Ordinance No. 06-09\Amended and Updated 8-26-08 by Resolution No. 08-10\Approved 10-28-08 by Ordinance No. 08-11\Amended and Updated 06-26-12 by Ordinance No. 12-02\Amended and Updated 4-23-13 by Ordinance No. 13-04\Amended and Updated 4-22-14 by Ordinance No. 14-02\Amended and Updated 8-26-14 by Ordinance No. 14-06\Amended and Updated 2-24-15 by Ordinance No. 15-04\Amended and Updated 1-26-16 by Ordinance No. 16-02\Amended and Updated 3-22-16 by Ordinance No. 16-04\Amended and Updated 1-23-18 by Ordinance No. 18-02\Amended and Updated 3-27-18 by Ordinance No. 18-05\DRAFT



## Standing District Committee Members

A member or alternate committee member of a Rainbow Municipal Water District standing committee serves at the pleasure of the Board. These committees are advisory to the Board with regard to matters within their respective areas of responsibility. A committee has jurisdiction to consider and make a recommendation to other committees and to the Board regarding any item of business within the responsibility of the committee. Committee recommendations shall be communicated to the Board. A committee may consider other matters referred to it by the Board. Therefore, standing district committee members shall be considered non-designated positions and will file Statements of Economic Interest forms with the District only for public review and information purposes.

\\rmwd-b\Store02\DriveC\Data\Drive-E\ADMINISTRATIVE CODE\Drafts\_Not Approved\Conflict of Interest 1.02.020.docx\\Approved 8-3-05 by Ordinance No. 05-07\\Amended and Updated 7-21-06 by Resolution No. 06-10\\Approved 11-17-06 by Ordinance No. 06-09\\Amended and Updated 8-26-08 by Resolution No. 08-10\\Approved 10-28-08 by Ordinance No. 08-11\\Amended and Updated 06-26-12 by Ordinance No. 12-02\\Amended and Updated 4-23-13 by Ordinance No. 13-04\\Amended and Updated 4-22-14 by Ordinance No. 14-02\\Amended and Updated 8-26-14 by Ordinance No. 14-06\\Amended and Updated 2-24-15 by Ordinance No. 15-04\\Amended and Updated 1-26-16 by Ordinance No. 16-02\\Amended and Updated 3-22-16 by Ordinance No. 16-04\\Amended and Updated 1-23-18 by Ordinance No. 18-02\\Amended and Updated 3-27-18 by Ordinance No. 18-05\\DRAFT



---

## BOARD OF DIRECTORS

May 22, 2018

---

### SUBJECT

DISCUSSION AND POSSIBLE ACTION TO APPROVE ORDINANCE NO. 18-13 - AMENDING AND UPDATING ADMINISTRATIVE CODE CHAPTER 2.09 – COMMITTEES

### BACKGROUND

The Communications Committee discussed amending the committee's charter found in Administrative Code Chapter 2.09 to include customer service. At their May 3, 2018 meeting, the members voted to recommend the Board approve this amendment.

### DESCRIPTION

Administrative Code Chapter 2.09 has been amended to include customer service which includes being responsible for matters of internal and external communications including: positive public image; positive staff relationships; community outreach; media relations; water conservation programs; intergovernmental relations; customer service policies; and other public relations programs.

### POLICY/STRATEGIC PLAN KEY FOCUS AREA

Administrative Code Chapters 2.09.

Strategic Focus Area Five: Customer Service

Strategic Focus Area Six: Communications

### BOARD OPTIONS/FISCAL IMPACTS

- 1) Approve Ordinance No. 18-13 amending and updating Administrative Code Chapter 2.09.
- 2) Approve Ordinance No. 18-13 amending and updating Administrative Code Chapter 2.09 with revisions.
- 3) Provide staff with further direction.
- 4) Do not approve Ordinance No. 18-13 amending and updating Administrative Code Chapter 2.09.

There will be no known direct fiscal impact associated with any of the Board Options.

**STAFF RECOMMENDATION**

Approve Ordinance No. 18-13 amending and updating Administrative Code Chapter 2.09.

---



---

Tom Kennedy, General Manager

May 22, 2018

**Ordinance No. 18-13**

**Ordinance of the Board of Directors of the Rainbow Municipal Water District  
Amending the Administrative Code  
Chapter 2.09 – Committees**

WHEREAS, the Rainbow Municipal Water District has, from time to time, adopted various rules and regulations for the operation of the District; and

WHEREAS, certain of those rules and regulations require updating to reflect best practices, as well as changes in applicable laws; and

WHEREAS, the Board of Directors has determined that changes in the rules or regulations of the District shall occur solely by amendment to the Administrative Code;

NOW, THEREFORE,

BE IT ORDAINED by the Board of Directors of Rainbow Municipal Water District as follows:

1. The following rules and regulations of the District, collected are hereby adopted and shall be incorporated into the Administrative Code, consisting of:

Chapter 2.09: Committees

2. The General Manager is hereby directed to update the Administrative Code to reflect the approval of these rules and regulations, and to assign or reassign the numbering of the Administrative Code as necessary to codify these rules and regulations as amended.

3. This ordinance shall take effect immediately upon its adoption on this 22nd day of May 2018.

**AYES:**  
**NOES:**  
**ABSTAIN:**  
**ABSENT:**

\_\_\_\_\_  
Helene Brazier, Board President

**ATTEST:**

\_\_\_\_\_  
Dawn Washburn, Board Secretary



## Chapter 2.09 COMMITTEES

### Section 2.09 Committees

The Board shall organize committees that are advisory to the Board with regard to matters within their respective areas of responsibility.

Each committee shall have at least four and no more than seven regular members appointed by a simple majority vote of the Board. Each committee may also have up to two alternate committee members appointed by a simple majority of the Board. Committees may be comprised of Directors, staff, and legal ratepayers of the District. Each committee shall designate their own chairperson. In order to promote attendance by Directors at Committee meetings without inadvertently creating a violation of the Ralph M. Brown Act, no more than one member of the Board of Directors may sit as a member on a Committee. Directors that are not members of a committee may attend as observers, but are allowed to participate at the Committee's request.

Members of the committees serve at the pleasure of the Board. Each committee may elect a vice-chairperson. Members of committees, including the chairperson and vice-chairperson shall serve until their successors are appointed. The chairperson of a committee is its presiding officer and shall be responsible for communicating the recommendation of the committee to the Board. In the absence of the chairperson, the vice-chairperson shall perform the duties of the chairperson. The chairperson and vice-chairperson are not deprived of any of the rights and privileges of a committee member by reason of being the presiding officer.

The initial committee chairpersons and vice-chairpersons will hold their position until January, 2009 at which time the committee members will hold elections to fill both positions. Thereafter the chairperson and vice-chairperson will hold their positions for one calendar year. Committee members will serve a term of four years and may be reappointed at the will of the Board.

Committee meetings shall be held in accordance with the provisions of the Ralph M. Brown Act. Notice of meetings of committees shall be posted 72 hours in advance pursuant to law and shall be considered regular meetings of the committee.

The committee shall record summary minutes of each lawfully noticed committee meeting. The minutes of each committee meeting and any recommendation of a committee shall include a summary of the information presented. District staff will prepare minutes of each meeting. Draft minutes shall be provided to the District Board and Committee Chairs as soon as practical following the committee meeting, and an approved copy shall be provided to the Directors in their monthly agenda packages.

A majority of the members of each committee shall constitute a quorum for the transaction of business.

Only regular members of the committee are entitled to make, second or vote on any motion or other action of the committee. Alternate members present at a meeting, but not seated as a regular member by the committee Chairperson, may participate in discussions but may not participate in motions or voting. Each committee member shall be entitled to one vote on all matters considered by the committee. A simple majority vote of the members of the Committee shall designate approval of a motion.

~~\\rmwd-b\Store02\DriveC\Data\Drive-E\ADMINISTRATIVE CODE\Drafts\_Not Approved\Committees 2.09.docx~~~~\\rmwd-b\Store03\BoardFiles\Board Secretary\Administrative Code Working File\Board Admin Code 2005-2006\Committees 2.09.docx~~\\Approved and Incorporated 3-27-07 by Ordinance No. 07-04\\Amended and Approved 08-28-07 by Ordinance No. 07-11\\Amended and Approved 11-7-07 by Ordinance No. 07-17\\Amended and Approved 1-27-09 by Ordinance No. 09-02\\Amended and Approved 06-24-14 by Ordinance No. 14-04\\Amended and Approved 9-27-16 by Ordinance No. 16-13\\Amended and Approved 4-24-18 by Ordinance No. 18-10\\**DRAFT**

All committee member absences will be considered by the majority of the committee members to determine whether or not the absence is without cause. Sickness, jury duty, vacation and/or bereavement will be considered excused absences. When three meetings in a row or a total of six meetings in one calendar year are missed the remaining committee members will consider removal of the individual from the committee. The removal must be voted upon and approved by the majority of the committee members with the exception of the committee member in question.

If the roll call of regular members reveals that a quorum of regular members cannot be established, the Chairperson may appoint one or more alternate members who are present to be a temporary regular member in order to establish a quorum. Once a quorum is established, any remaining alternate member who has not been appointed as a temporary regular member shall remain as an alternate member. Once alternates have been seated as a regular committee member, they may immediately participate in any action taken and voted upon by the committee. All alternates must conform to the same rules as regular committee members. The Chairperson shall state for the record which alternate members have been seated as temporary regular members.

Committee Members and alternates shall comply with the obligations and responsibilities of office including the obligation to comply with the disclosure requirements of the Political Reform Act (Form 700). The reporting categories made applicable to the Directors by Rainbow Municipal Water District's local conflict of code shall apply to the members of the committee members.

All committee communications must go through the designated committee chairperson.

A committee has jurisdiction to consider and make a recommendation to staff, other committees and to the Board regarding any item of business within the responsibility of the committee. Committee recommendations shall be communicated to the Board. A committee may consider other matters referred to it by the Board.

The Board may refer a recommendation back to the committee for reevaluation whenever the Board deems additional evaluation is required.

### **2.09.010 Budget and Finance Committee**

The Committee shall work in concert with the General Manager, Treasurer, and Finance Manager of the District.

The Committee shall be responsible for the review of District finances including: rates, fees, charges and other sources of revenue; budget; audit; investments; insurance; and other financial matters.

### **2.09.020 Engineering and Operations Committee**

The Committee shall work in concert with the General Manager, District Engineer, and Operations Manager.

The Committee shall be responsible to review matters of design, construction, replacement, and repair of the District facilities and property, including: the Capital Improvement Program; contractor selection process; contractor management programs; and other engineering-related matters.

~~\\rmwd-b\Store02\DriveC\Data\Drive-E\ADMINISTRATIVE CODE\Drafts\_Not Approved\Committees 2.09.docx~~ \\rmwd-b\Store03\BoardFiles\Board Secretary\Administrative Code Working File\Board Admin Code 2005-2006\Committees 2.09.docx \\Approved and Incorporated 3-27-07 by Ordinance No. 07-04\\Amended and Approved 08-28-07 by Ordinance No. 07-11\\Amended and Approved 11-7-07 by Ordinance No. 07-17\\Amended and Approved 1-27-09 by Ordinance No. 09-02\\Amended and Approved 06-24-14 by Ordinance No. 14-04\\Amended and Approved 9-27-16 by Ordinance No. 16-13\\Amended and Approved 4-24-18 by Ordinance No. 18-10\\DRAFT



The committee shall also be responsible to review matters of operations, preventative maintenance practices, standard operating procedures, technical services, equipment, and other operations-related matters.

### **2.09.030 Communications and Customer Service Committee**

The Committee shall work in concert with the General Manager.

The Committee shall be responsible for matters of internal and external communications including: positive public image; positive staff relationships; community outreach; media relations; water conservation programs; intergovernmental relations; customer service policies; and other public relations programs.



## **Chapter 2.09 COMMITTEES**

### **Section 2.09 Committees**

The Board shall organize committees that are advisory to the Board with regard to matters within their respective areas of responsibility.

Each committee shall have at least four and no more than seven regular members appointed by a simple majority vote of the Board. Each committee may also have up to two alternate committee members appointed by a simple majority of the Board. Committees may be comprised of Directors, staff, and legal ratepayers of the District. Each committee shall designate their own chairperson. In order to promote attendance by Directors at Committee meetings without inadvertently creating a violation of the Ralph M. Brown Act, no more than one member of the Board of Directors may sit as a member on a Committee. Directors that are not members of a committee may attend as observers, but are allowed to participate at the Committee's request.

Members of the committees serve at the pleasure of the Board. Each committee may elect a vice-chairperson. Members of committees, including the chairperson and vice-chairperson shall serve until their successors are appointed. The chairperson of a committee is its presiding officer and shall be responsible for communicating the recommendation of the committee to the Board. In the absence of the chairperson, the vice-chairperson shall perform the duties of the chairperson. The chairperson and vice-chairperson are not deprived of any of the rights and privileges of a committee member by reason of being the presiding officer.

The initial committee chairpersons and vice-chairpersons will hold their position until January, 2009 at which time the committee members will hold elections to fill both positions. Thereafter the chairperson and vice-chairperson will hold their positions for one calendar year. Committee members will serve a term of four years and may be reappointed at the will of the Board.

Committee meetings shall be held in accordance with the provisions of the Ralph M. Brown Act. Notice of meetings of committees shall be posted 72 hours in advance pursuant to law and shall be considered regular meetings of the committee.

The committee shall record summary minutes of each lawfully noticed committee meeting. The minutes of each committee meeting and any recommendation of a committee shall include a summary of the information presented. District staff will prepare minutes of each meeting. Draft minutes shall be provided to the District Board and Committee Chairs as soon as practical following the committee meeting, and an approved copy shall be provided to the Directors in their monthly agenda packages.

A majority of the members of each committee shall constitute a quorum for the transaction of business.

Only regular members of the committee are entitled to make, second or vote on any motion or other action of the committee. Alternate members present at a meeting, but not seated as a regular member by the committee Chairperson, may participate in discussions but may not participate in motions or voting. Each committee member shall be entitled to one vote on all matters considered by the committee. A simple majority vote of the members of the Committee shall designate approval of a motion.

All committee member absences will be considered by the majority of the committee members to determine whether or not the absence is without cause. Sickness, jury duty, vacation and/or bereavement will be considered excused absences. When three meetings in a row or a total of six meetings in one calendar year are missed the remaining committee members will consider removal of the individual from the committee. The removal must be voted upon and approved by the majority of the committee members with the exception of the committee member in question.

If the roll call of regular members reveals that a quorum of regular members cannot be established, the Chairperson may appoint one or more alternate members who are present to be a temporary regular member in order to establish a quorum. Once a quorum is established, any remaining alternate member who has not been appointed as a temporary regular member shall remain as an alternate member. Once alternates have been seated as a regular committee member, they may immediately participate in any action taken and voted upon by the committee. All alternates must conform to the same rules as regular committee members. The Chairperson shall state for the record which alternate members have been seated as temporary regular members.

Committee Members and alternates shall comply with the obligations and responsibilities of office including the obligation to comply with the disclosure requirements of the Political Reform Act (Form 700). The reporting categories made applicable to the Directors by Rainbow Municipal Water District's local conflict of code shall apply to the members of the committee members.

All committee communications must go through the designated committee chairperson.

A committee has jurisdiction to consider and make a recommendation to staff, other committees and to the Board regarding any item of business within the responsibility of the committee. Committee recommendations shall be communicated to the Board. A committee may consider other matters referred to it by the Board.

The Board may refer a recommendation back to the committee for reevaluation whenever the Board deems additional evaluation is required.

### **2.09.010 Budget and Finance Committee**

The Committee shall work in concert with the General Manager, Treasurer, and Finance Manager of the District.

The Committee shall be responsible for the review of District finances including: rates, fees, charges and other sources of revenue; budget; audit; investments; insurance; and other financial matters.

### **2.09.020 Engineering and Operations Committee**

The Committee shall work in concert with the General Manager, District Engineer, and Operations Manager.

The Committee shall be responsible to review matters of design, construction, replacement, and repair of the District facilities and property, including: the Capital Improvement Program; contractor selection process; contractor management programs; and other engineering-related matters.

The committee shall also be responsible to review matters of operations, preventative maintenance practices, standard operating procedures, technical services, equipment, and other operations-related matters.

### **2.09.030 Communications and Customer Service Committee**

The Committee shall work in concert with the General Manager.

The Committee shall be responsible for matters of internal and external communications including: positive public image; positive staff relationships; community outreach; media relations; water conservation programs; intergovernmental relations; customer service policies; and other public relations programs.





## BOARD INFORMATION

---

### BOARD OF DIRECTORS

May 22, 2018

---

#### SUBJECT

STAFFING ANALYSIS UPDATE

---

#### DESCRIPTION

The purpose of this information report is to present the Board with an updated staffing analysis for the District. This staffing analysis forecasts the organizational and personnel changes required to maintain a successful workforce plan for the next five fiscal years (FY 2018-2019 to 2023-2024).

The written report, to be delivered to the Board in hard copy under separate cover, shows the recommended staffing levels for the coming fiscal year to increase operational efficiencies, provide better service to our customers, and prepare staff for future leadership opportunities. This report also serves as a key reference tool for succession planning purposes. This analysis will be living document that will be updated annually as operational needs evolve.

This report was prepared by the Human Resources Manager after consultations with the senior management team. The recommendations reflect the team's collective observations, concerns, departmental succession plans and recommendations.

The fiscal impact of the recommendations will be included in the 2017-2018 budget that will be presented to the Board for consideration in June.

---

Karleen Harp  
Human Resources Manager

05/22/2018





### BOARD OF DIRECTORS

May 22, 2018

---

#### **SUBJECT**

CONSIDER A PROFESSIONAL SERVICES AGREEMENT WITH KINSEY AND KINSEY INC. FOR IMPLEMENTATION SERVICES RELATED TO THE INFOR CLOUDSUITE FINANCIALS SOFTWARE SYSTEM IN THE AMOUNT OF \$163,800 AND AUTHORIZE THE GENERAL MANAGER TO EXECUTE THE CONTRACT ON THE DISTRICT'S BEHALF

#### **DESCRIPTION**

This agenda item is for approval of a Professional Services Agreement (PSA) with Kinsey and Kinsey Inc. (hereafter Kinsey) for implementation and data conversion services required to deploy the new finance software from Infor Global Solutions that will replace the current system from Acela Springbrook. Staff worked with Infor to identify a cost effective implementation methodology and through this process Kinsey was selected for this work.

#### **BACKGROUND**

In 2014 the District was informed by its finance and utility billing software vendor, Datastream Business Solutions, that the company had been acquired by Springbrook (now Acella) and would be shutting down its operations. As part of the acquisition, Springbrook offered a migration path to use their software. Faced with few options that could meet the time schedule of the ending of Datastream support, and based on incentives and promises of improved functionality in the Springbrook software, the District completed a conversion of its finance and utility billing software from Datastream to Springbrook in 2016.

Unfortunately, the promises of improved functionality did not pan out. The Springbrook software, commonly referred to by staff as "Springbroke", has proven to have numerous functional flaws that challenge staff on a daily basis. Worse, the level of support offered by Springbrook is woefully inadequate, leaving staff to try to find work arounds when certain features fail to function properly. The reporting capability of the software is terrible and it cannot interface with our other information systems as was required in the contract.

After a series of discussions with the Budget and Finance Committee and the Board, the Board approved the procurement of the Infor Cloudsuite Financials software in January 2018. Since that time, staff has been working with Infor on implementation options. One option was to work with Infor's in-house implementation team but early on it was identified that this would not be a cost effective solution. Infor's in-house team generally only works on the largest of projects and their implementation fees were likely going to be well in excess of \$1 Million.

There are a number of consulting firms that specialize in Infor products and after reviewing several and having discussions with Infor staff identified Kinsey as a firm that both had the capabilities that we need for the work (Cloud certified by Infor) and were able to handle a smaller implementation such as ours. After a series of discussions Kinsey we refined the scope of work so that District staff will handle some of

the work that the consultant normally does. Our new IT Administrator has a skill set that will prove very useful in this process and shaved nearly \$80k off the cost of the implementation.

Kinsey's proposal is attached and will allow us to take a flexible approach to the implementation. There are a couple of steps that we took to control costs here:

- We are moving payroll over to one of the many payroll service firms that have systems that meet our needs. An RFP for this work was presented to the Budget and Finance Committee for consideration at the May meeting. Should the cost of this exceed the GM's authority it will also come to the Board for full consideration.
- We are moving purchasing and inventory into the existing EAM software. The EAM has a full featured system for this purpose that we had not been using. We are self- implementing this system using in-house talent.
- We will be using Infor ION software that is a "middleware" product that will tie all of these systems together for maximum data sharing. Our new IT Administrator has some experience in ION and will be taking some specialized training to help him with the configuration of this middleware

We expect the implementation process to take about 9 months although some elements of the system will come online earlier.

**POLICY/STRATEGIC PLAN KEY FOCUS AREA**

Strategic Focus Area Four – Fiscal Responsibility. A key part of fiscal responsibility is our capacity to track and report on all financial transactions. One of the big problems with the Springbrook software is that the reporting functionality was very weak. This lead to increased staff time to custom generate reports where possible and difficult to read reports in other areas. The Cloudsuite software has much better reporting functionality that will allow the Board, Budget and Finance Committee, as our ratepayers to have much better insight into our financial performance.

**BOARD OPTIONS/FISCAL IMPACTS**

The total contract cost is \$163,800. Kinsey feels that this number is very conservative and we are likely to come in under that amount. Of course, with any software implementation we may run into challenges so this is not a guarantee.

Funds for this work will be included in the FY19 budget as most of these costs will not accrue until after July 1, 2018.

**STAFF RECOMMENDATION**

Staff recommends that the Board approve the PSA with Kinsey in the amount of \$163,800 and authorize the General Manager to sign on the behalf of the District.

  
\_\_\_\_\_  
Tom Kennedy  
General Manager

May 22, 2018



**RAINBOW MUNICIPAL WATER DISTRICT  
3707 S HIGHWAY 395  
FALLBROOK CA 92028  
(760) 728-1178**

## **PROFESSIONAL SERVICES AGREEMENT**

THIS AGREEMENT ("Agreement") is made and entered into this 23rd day of May, 2018, by and between the RAINBOW MUNICIPAL WATER DISTRICT, a municipal water district, hereinafter designated as "DISTRICT", and Kinsey and Kinsey, an Illinois corporation hereinafter designated as "SPECIALIST."

### **RECITALS**

- A.** DISTRICT desires to obtain Professional Services from an independent contractor for the above-named Project.
- B.** SPECIALIST has submitted a proposal to provide professional services for the DISTRICT in accordance with the terms set forth in this Agreement.
- C.** DISTRICT desires to contract with SPECIALIST as an independent contractor and SPECIALIST desires to provide services to DISTRICT as an independent contractor.
- D.** SPECIALIST has demonstrated its competence and professional qualifications necessary for the satisfactory performance of the services designated herein by virtue of its experience, training, education, and expertise.

### **NOW THEREFORE, THE PARTIES MUTUALLY AGREE AS FOLLOWS:**

#### **1. PROFESSIONAL SERVICES PROVIDED BY SPECIALIST.**

- 1.1** The professional services to be performed by SPECIALIST shall consist of the following: Infor Cloudsuite Financials Implementation services. The scope of services is more particularly defined in Exhibit "A", attached and made a part hereof. Any additional services must be agreed to by the parties in writing as set forth in Section 19, as an amendment to this Agreement.
- 1.2** In performing the services set forth in this Agreement including Exhibit "A", SPECIALIST shall work closely with the DISTRICT'S General Manager and staff in performing the services in accordance with this Agreement in order to receive clarification as to the result that the DISTRICT expects to be accomplished by SPECIALIST. The General Manager

shall be the DISTRICT'S authorized representative in the interpretation and enforcement of all services performed in connection with this Agreement.

- 1.3 SPECIALIST represents that its employees have the qualifications and skills necessary to perform the services under this Agreement in a competent, professional manner, without the advice or direction of the DISTRICT. This means SPECIALIST is able to fulfill the requirements of this Agreement. Failure to perform all services required under this Agreement constitutes a material breach of the Agreement.

## **2. TERM AND TIMING REQUIREMENTS.**

- 2.1 This Agreement will become effective on the date stated above, and will continue in effect until the earlier of the completion of services provided for in this Agreement or until terminated as provided under Section 14 of this Agreement.
- 2.2 Performance of work under this Agreement shall be in accordance with the schedule outlined in Exhibit "A" unless otherwise modified in writing as set forth in Section 19. Failure by SPECIALIST to strictly adhere to these timing requirements may result in termination of this Agreement by the DISTRICT.
- 2.3 SPECIALIST shall submit all requests for extensions of time for performance in writing to the General Manager and in all cases prior the date on which performance is due if possible. The General Manager shall review all such requests and may grant reasonable time extensions for unforeseeable delays which are beyond SPECIALIST'S control.
- 2.4 For all time periods not specifically set forth herein, SPECIALIST shall respond in the most expedient and appropriate manner under the circumstances, by telephone, fax, hand delivery, e-mail or mail.

## **3. IMPLEMENTATION CRITERIA AND STANDARDS.**

All work shall be performed in accordance with applicable DISTRICT, county, state and federal Codes and criteria. In the performance of its professional services, SPECIALIST shall use the degree of care and skill ordinarily exercised by specialists performing the same or similar work under similar conditions.

## **4. INDEPENDENT CONTRACTOR.**

- 4.1 SPECIALIST'S relationship to the DISTRICT shall be that of an independent contractor in performing all services hereunder. The DISTRICT shall not exercise any control or direction over the methods by which CONTRACTOR shall perform its services and functions. The DISTRICT'S sole interest and responsibility is to ensure that the services covered in this Agreement are performed in a competent, satisfactory and legal manner. The parties agree that no services, act, commission or omission of SPECIALIST or its employee(s) pursuant to this Agreement shall be construed to make SPECIALIST or its employee(s) the agent, employee or servant of the DISTRICT. SPECIALIST and its employee(s) are not entitled to receive from the DISTRICT vacation pay, sick leave, retirement benefits, Social Security, workers' compensation, disability benefits, unemployment benefits or any other employee benefit of any kind.
- 4.2 SPECIALIST shall be solely responsible for paying all federal and state employment and income taxes, for carrying workers' compensation insurance and for otherwise complying

with all other employment requirements with respect to SPECIALIST or its employee(s). SPECIALIST agrees to indemnify, defend and hold the DISTRICT harmless from any and all liability, damages or losses (including attorneys' fees, costs, penalties and fines) the DISTRICT suffers as a result of SPECIALIST'S failure comply with the foregoing.

**4.3** SPECIALIST shall be solely responsible for the performance of any of its employees, agents, or subcontractors under this Agreement. SPECIALIST shall report to the DISTRICT any and all employees, agents, and subcontractors performing work in connection with this Agreement, and all shall be subject to the approval of the DISTRICT.

**4.4** SPECIALIST shall have no authority, express or implied, to act on behalf of the DISTRICT as an agent, or to bind the DISTRICT to any obligation whatsoever, unless specifically authorized in writing by the General Manager.

**5. WORKERS' COMPENSATION INSURANCE.**

By SPECIALIST'S signature hereunder, SPECIALIST certifies that SPECIALIST is aware of the provisions of Section 3700 of the California Labor Code which require every employer to be insured against liability for workers' compensation or to undertake self-insurance in accordance with the provisions of that code, and SPECIALIST will comply with such provisions before commencing the performance of the services pursuant to this Agreement.

**6. INDEMNIFICATION, HOLD HARMLESS AND DEFENSE.**

**6.1** To the extent and in any manner permitted by law, SPECIALIST shall defend, indemnify, and hold DISTRICT, its directors, officers, employees, authorized volunteers and agents, and each of them free and harmless from any liability from claims, demands, loss, damage, or injury to property or persons, including wrongful death, in any manner arising out of, related to or incident to, in whole or in part, any act or omission of SPECIALIST, including SPECIALIST'S officers, employees and agents, in connection with the services required by this Agreement, including without limitation, the payment of reasonable attorneys' fees and costs. All officers, agents, employees and subcontractors, and their agents, who are employed, contracted or otherwise utilized by SPECIALIST to perform services under this Agreement, shall be deemed officers, agents and employees of SPECIALIST. The foregoing indemnity, hold harmless and defense obligation of SPECIALIST shall apply except to the extent the loss, damage or injury is caused by the sole negligence or willful misconduct of an indemnified party.

**6.2** To the extent and in any matter permitted by law, SPECIALIST shall defend, indemnify and hold the DISTRICT, its directors, officers, employees, authorized volunteers and agents, and each of them free and harmless from and against any and all claims, demands, actions, proceedings, damages, costs, expenses, penalties or liabilities, in law or equity, of every kind or nature whatsoever, arising out of, related to or incident to a breach of this Agreement, any assertion that any of the materials, services, hardware or software provided by SPECIALIST to the DISTRICT ("Specialist Products") or the use thereof infringes any patent, copyright or proprietary right of any third party, or the violation of any governmental law or regulations, compliance with which is the responsibility of SPECIALIST.

- 6.3** SPECIALIST shall defend, at SPECIALIST'S own cost, expense and risk, any and all such aforesaid claims, demands, suits, actions or other legal proceedings of every kind that may be brought or instituted against the DISTRICT or the DISTRICT'S directors, officers, employees, authorized volunteers and agents, and each of them. The DISTRICT shall be consulted regarding and approve of the selection of defense counsel. Should separate counsel be necessary for the DISTRICT, as determined by the DISTRICT, SPECIALIST shall be responsible to pay for the reasonable attorneys' fees and costs including expert fees, as such fees and costs are incurred, for the DISTRICT'S legal counsel in addition to SPECIALIST'S own legal fees and costs. In all circumstances, DISTRICT retains the right to retain its own attorneys.
- 6.4** SPECIALIST shall pay and satisfy any judgment, award or decree that may be rendered against DISTRICT or its directors, officers, employees, authorized volunteers and agents, and each of them, in any and all such aforesaid claims, demands, suits, action or other legal proceeding. SPECIALIST shall not agree without the DISTRICT'S prior written consent, to any settlement which would require the DISTRICT to pay any money or perform some affirmative act, including in the case of intellectual property infringement any payment of money or performance of some affirmative act to continue using the Specialist Products.
- 6.5** SPECIALIST shall reimburse DISTRICT and its directors, officers, employees, authorized volunteers and agents, and each of them, for any and all legal expenses and costs including attorneys' fees incurred by each of them in connection therewith or in enforcing the indemnity, hold harmless and defense obligation herein provided.
- 6.6** SPECIALIST agrees to carry insurance for this purpose as set forth herein including contract liability. Provision of insurance coverage as required by this Agreement shall not affect SPECIALIST'S indemnification, hold harmless and defense obligations. SPECIALIST'S indemnification, hold harmless and defense obligation shall not be limited in any way by any limitation on the amount or type of damages, compensation or benefits payable by or for SPECIALIST, subcontractor, supplier or other person under workers' compensation acts, disability acts or other employee acts or the insurance required by this Agreement. SPECIALIST'S indemnification, hold harmless and defense obligation shall not be restricted to insurance proceeds, if any received by the DISTRICT or its directors, officers, employees, authorized volunteers or agents.
- 6.7** SPECIALIST'S indemnification, hold harmless and defense obligation shall survive the termination or expiration of this Agreement.

**7. LAWS, REGULATIONS AND PERMITS.**

- 7.1** SPECIALIST shall give all notices required by law and comply with all laws, ordinances, rules and regulations pertaining to the conduct of the services required by this Agreement. SPECIALIST shall be liable for and bear all costs resulting from, any violations of the law in connection with services furnished by SPECIALIST.

**8. SAFETY.**

SPECIALIST shall execute and maintain SPECIALIST'S services so as to avoid injury or damage to any person or property. In carrying out SPECIALIST'S services, SPECIALIST shall at all times, exercise all necessary precautions for the safety of employees

appropriate to the nature of the services and the conditions under which the services are to be performed, and be in compliance with all federal, state and local statutory and regulatory requirements including State of California, Division of Industrial Safety (Cal/OSHA) regulations, and the U.S. Department of Transportation Omnibus Transportation Employee Testing Act (as applicable). Safety precautions as applicable shall include instructions in accident prevention for all employees such as safe walkways, scaffolds, fall protection, ladders, bridges, gang planks, confined space procedures, trenching & shoring, equipment and wearing apparel as are necessary or lawfully required to prevent accidents or injuries.

**9. INSURANCE.**

**9.1 INSURANCE COVERAGE AND LIMITS.**

SPECIALIST shall provide and maintain at all times during the performance of this Agreement, insurance against claims for injuries to persons or damages to property which may arise from or in connection with the performance of the services hereunder by SPECIALIST, its agents, representatives, employees or subcontractors. Claims made policies shall not satisfy these insurance requirements unless SPECIALIST notifies DISTRICT and obtains DISTRICT'S prior written consent to the use of such claims made policies.

**Coverage** – SPECIALIST shall maintain coverage shall be at least as broad as the following:

- a) Coverage for Professional Liability appropriate to SPECIALIST'S profession covering SPECIALIST'S wrongful acts, negligent actions, errors or omissions. The retroactive date (if any) is to be no later than the effective date of this Agreement.
- b) Insurance Services Office Commercial General Liability Coverage (Occurrence Form CG 0001).
- c) Insurance Services Office Automobile Liability Coverage (Form CA 0001), covering Symbol 1 (any auto).
- d) Workers' Compensation insurance as required by the State of California and Employers Liability insurance.

**Limits** - SPECIALIST shall maintain limits no less than the following:

- a) Professional Liability - One Million Dollars (\$1,000,000) per claim and Two Million Dollars (\$2,000,000) annual aggregate.
- b) General Liability - Two Million Dollars (\$2,000,000) per occurrence for bodily injury, personal injury and property damage. If Commercial General Liability Insurance or other form with a general aggregate limit or products-completed operations aggregate limit is used, either the general aggregate limit shall apply separately to the project/location (with the ISO CG 2503, or ISO CG 2504, or insurer's equivalent endorsement provided to the DISTRICT) or the general aggregate limit and products-completed operations aggregate limit shall be twice the required occurrence limit.

- c) Automobile Liability - One Million Dollars (\$1,000,000) for bodily injury and property damage each accident limit.
- d) Workers' Compensation insurance with statutory limits as required by California law and Employer's Liability insurance with a limit of no less than One Million Dollars (\$1,000,000) per accident for bodily injury or disease.

**9.2 REQUIRED INSURANCE PROVISIONS.** The insurance policies are to contain, or be endorsed to contain the following provisions:

- a) The DISTRICT, its directors, officers, employees, or authorized volunteers are to be covered as insureds on the CGL and auto policies with respect to liability arising out of automobiles owned, leased, hired, or borrowed by on or behalf of SPECIALIST; and with respect to liability arising out of services or operations performed by or on behalf of SPECIALIST including materials, parts, or equipment furnished in connection with such services or operations. General liability coverage can be provided in the form of an endorsement to SPECIALIST'S insurance (at least as broad as ISO Form CG 20 10, 11 85 or both CG 20 10 and CG 20 37 forms if later revisions used). The coverage shall contain no special limitations on the scope of protection afforded to the DISTRICT, its directors, officers, employees, or authorized volunteers. The Project Name shall also be included.
- b) For any claims related to the services provided hereunder, SPECIALIST'S insurance shall be primary insurance as respects the DISTRICT, its directors, officers, employees, and authorized volunteers. Any insurance, self-insurance, or other coverage maintained by the DISTRICT, its directors, officers, employees, or authorized volunteers shall not contribute to it.
- c) Each insurance policy specified above are to state or be endorsed to state that coverage shall not be canceled except after thirty (30) days prior written notice ten (10) days for non-payment of premium) by U.S. mail has been provided to the DISTRICT.
- d) In the event any change is made in the insurance carrier, scope of coverage or retroactive date of professional liability coverage required under this Agreement (if applicable), SPECIALIST shall notify the DISTRICT prior to any changes.
- e) All of the insurance shall be provided on policy forms satisfactory to the DISTRICT. All insurance correspondence, notations, certificates, or other documents from the insurance carrier or agent/broker shall each separately reference this Agreement.

**9.3 WAIVER OF SUBROGATION.** SPECIALIST hereby agrees to waive rights of subrogation which any insurer of SPECIALIST may acquire from SPECIALIST by virtue of the payment of any loss. SPECIALIST agrees to obtain any endorsement that may be necessary to affect this waiver of subrogation. The Workers' Compensation policy shall be endorsed with a waiver of subrogation in favor of DISTRICT for all services performed by SPECIALIST, its employees, agents and subcontractors.

**9.4 DEDUCTIBLES AND SELF-INSURED RETENTIONS.** Any deductible or self-insured retention must be declared to and approved by the DISTRICT. At the option of the



DISTRICT, the insurer shall either reduce or eliminate such deductibles or self-insured retention.

**9.5 ACCEPTABILITY OF INSURERS.** Insurance is to be placed with insurers having a current A.M. Best rating of no less than A:VII or equivalent or as otherwise acceptable to the DISTRICT.

**9.6 EVIDENCES OF INSURANCE.** Prior to execution of this Agreement, SPECIALIST shall furnish the DISTRICT with original certificates and amendatory endorsements, or copies of the applicable insurance language, effecting coverage required by this Agreement. All certificates and endorsements are to be received and approved by the District before services commence. However, failure to obtain the required documents prior the services beginning shall not waive SPECIALIST'S obligation to provide them.

SPECIALIST shall, upon demand of the DISTRICT at any time, deliver to the DISTRICT complete, certified copies or all required insurance policies, including endorsements, required by this Agreement.

**9.7 SUBCONTRACTORS.** In the event that SPECIALIST employs subcontractors as part of the services covered by this Agreement, it shall be the SPECIALIST'S responsibility to require and verify that each subcontractor meets the minimum insurance requirements specified in this Agreement.

**10. NO CONFLICT OF INTEREST.**

If SPECIALIST is providing services related to a DISTRICT project, SPECIALIST shall not be financially interested in any other contract necessary for the undertaking of the project. For the limited purposes of interpreting this section, SPECIALIST shall be deemed a "district officer or employee", and this section shall be interpreted in accordance with California Government Code Section 1090. In the event that SPECIALIST becomes financially interested in any other contract necessary for the undertaking of the project, this Agreement shall be null and void and DISTRICT shall be relieved of any responsibility whatsoever to provide compensation under the terms and conditions of any such contract for those services performed by SPECIALIST.

**11. OWNERSHIP OF DOCUMENTS AND MATERIALS.**

All documents, diskettes, drawings, reports and specifications, including details, computations, and other documents and materials, prepared or provided by SPECIALIST under this Agreement shall be furnished to and become the property of the DISTRICT. The DISTRICT agrees to hold the SPECIALIST free and harmless from any claim arising from any use, other than the purpose intended, of the documents and materials prepared or provided by SPECIALIST. SPECIALIST may retain a copy of all material produced by SPECIALIST under this Agreement for the purpose of documenting their services.

**12. CONFIDENTIAL INFORMATION.**

Any written, printed, graphic, or electronically or magnetically recorded information furnished by the DISTRICT for SPECIALIST'S use are the sole property of the DISTRICT. SPECIALIST and its employee(s) shall keep this information in the strictest confidence, and will not disclose it by any means to any person except with the DISTRICT'S prior written approval, and only to the extent necessary to perform the services under this

Agreement. This prohibition also applies to SPECIALIST'S employees, agents and subcontractors. On termination or expiration of this Agreement, SPECIALIST shall promptly return any such confidential information in its possession to the DISTRICT.

**13. COMPENSATION.**

**13.1** For services performed by SPECIALIST in accordance with this Agreement, DISTRICT shall pay SPECIALIST on a time and materials basis and in accordance with the schedule of billing rates set forth in Exhibit "A", attached hereto and incorporated herein by reference. No rate changes shall be made during the term of this Agreement. SPECIALIST'S compensation for all services performed in accordance with this Agreement shall not exceed the total contract price of \$163,800. No services shall be performed by SPECIALIST in excess of the total contract price without prior written approval of the General Manager. SPECIALIST shall obtain approval from the General Manager prior to performing any services that result in incidental expenses to DISTRICT.

**13.2** SPECIALIST shall maintain accounting records including the following information:

- a) Names and titles of employees or agents, types of services performed, and times and dates of all services performed in connection with Agreement that is billed on an hourly basis.
- b) All incidental expenses including reproductions, computer printing, postage, mileage –billed at current Internal Revenue Service ("IRS") Rate, and subsistence.

**13.3** SPECIALIST'S accounting records shall be made available to the DISTRICT Accounting Manager, for verification of billings, within a reasonable time of the Accounting Manager's request for inspection.

**13.4** SPECIALIST shall submit monthly invoices to DISTRICT. DISTRICT shall make partial payments to SPECIALIST not to exceed the total contract price within thirty (30) days of receipt of invoice, subject to the approval of the General Manager. SPECIALIST shall ensure that any report generated under this Agreement shall comply with Government Code Section 7550.

**14. TERMINATION OF AGREEMENT.**

**14.1** If DISTRICT ("demanding party") has a good faith belief that SPECIALIST is not complying with the terms of this Agreement, the DISTRICT shall give written notice of the default (with reasonable specificity) to SPECIALIST and demand the default to be cured within ten (10) calendar days of the notice.

**14.2** If SPECIALIST fails to cure the default within ten (10) calendar days of the notice, or if more than ten (10) calendar days are reasonably required to cure the default, and SPECIALIST fails to give adequate assurance and due performance within ten (10) calendar days of the notice, the DISTRICT may immediately terminate this Agreement upon written notice to SPECIALIST.

**14.3** In the event of a material breach of any representation or term of this Agreement by SPECIALIST that is not curable or results in a threat to health or safety, the DISTRICT may immediately terminate this Agreement by providing written notice and without a cure period.

**14.4** Upon termination, the DISTRICT shall pay SPECIALIST for any services completed up to and including the date of termination of this Agreement, minus any costs reasonably incurred by the DISTRICT related SPECIALIST'S services under this Agreement, in accordance with Section 13 regarding compensation. The DISTRICT shall be required to compensate SPECIALIST only for services performed in accordance with the Agreement up to and including the date of termination.

**15. ASSIGNMENT AND DELEGATION.**

**15.1** This Agreement and any portion thereof shall not be assigned or transferred, nor shall any of the SPECIALIST'S duties be delegated or subcontracted, without the express prior written consent of the DISTRICT. Any attempt to assign or delegate this Agreement without the express written consent of the DISTRICT shall be void and of no force or effect. Consent by the DISTRICT to one assignment shall not be deemed to be consent to any subsequent assignment.

**15.2** This Agreement shall inure to the benefit of and be binding upon the parties hereto and their respective successors and assigns.

**16. AUDIT DISCLOSURE.**

Pursuant to Government Code section 8546.7, if the Agreement is over Ten Thousand Dollars (\$10,000), it is subject to examination and audit of the State Auditor, at the request of the DISTRICT or as part of any audit of the DISTRICT, for a period of three (3) years after final payment under the Agreement. SPECIALIST shall cooperate with any such examination or audit at no cost to the DISTRICT.

**17. ENTIRE AGREEMENT.**

This Agreement, and the attached Exhibit "A", comprise the entire integrated understanding between the DISTRICT and SPECIALIST concerning the services to be performed pursuant to this Agreement and supersedes all prior negotiations, representations, or agreements whether express or implied, oral or written. The express terms hereof control and supersede any course of performance and/or usage of the trade inconsistent with any of the terms herein. In the event of any conflict between the provisions of the Agreement and the Exhibit(s), the terms of the Agreement shall prevail.

**18. INTERPRETATION OF THE AGREEMENT.**

**18.1** The interpretation, validity, and enforcement (including, without limitation, provisions concerning limitations of actions) of the Agreement shall be governed by and construed under the laws of the State of California, notwithstanding any conflict-of-laws doctrines of such state or other jurisdiction to the contrary and without the aid of any canon, custom or rule requiring construction against the draftsman. The Agreement does not limit any other rights or remedies available to the DISTRICT.

**18.2** SPECIALIST shall be responsible for complying with all applicable Local, State, and Federal laws whether or not said laws are expressly stated or referred to herein.

**18.3** Should any provision herein be found or deemed to be invalid, the Agreement shall be construed as not containing such provision, and all other provisions which are otherwise

lawful shall remain in full force and effect, and to this end the provisions of this Agreement are severable.

- 18.4** Each and every provision of law and clause required by law to be inserted in this Agreement shall be deemed to be inserted herein, and the Agreement shall be read and enforced as though they were included herein. If through mistake of otherwise any such provision is not inserted, or is not correctly inserted, then upon application of either party, the Agreement shall forthwith by physically amended to make such insertion.

**19. AGREEMENT MODIFICATION.**

This Agreement may not be modified orally or in any manner other than by an agreement in writing signed by the parties hereto.

**20. DISPUTE RESOLUTION.**

Upon the written demand of either party, any dispute, claim or controversy arising out of or relating to this Agreement, or the breach, termination, enforcement, interpretation or validity thereof, shall first be submitted to mediation the cost of which shall be borne equally by the parties, if not resolved pursuant to the Government Claims Act, Government Code Section 900 et seq. if applicable, and prior to the commencement of any legal action or other proceeding. Any mediation shall take place in the State of California, County of San Diego, and shall be concluded within sixty (60) calendar days of the written demand, unless such time is extended by mutual written consent of the parties. Nothing herein waives or excuses compliance with the California Government Claims Act.

In the event that mediation has not been successfully concluded within the time allowed, any dispute, claim or controversy arising out of or relating to this Agreement or the breach, termination, enforcement, interpretation or validity thereof, including the determination of the scope or applicability of this agreement to arbitrate, shall be determined by arbitration in the State of California, County of San Diego, before one arbitrator. The arbitration shall be administered by JAMS pursuant to its Comprehensive Arbitration Rules and Procedures if the amount in controversy is equal to or greater than Two Hundred Fifty Thousand Dollars (\$250,000), or pursuant to its Streamlined Arbitration Rules and Procedures if the amount in controversy is less than Two Hundred Fifty Thousand Dollars (\$250,000). The use of arbitration shall allow full discovery by all parties associated with the dispute or claim. Judgment on the award may be entered in any court having jurisdiction. This clause shall not preclude the parties from seeking provisional remedies in aid of arbitration from a court of competent jurisdiction. The arbitrator may, in the award, allocate all or a part of the costs of the arbitration, including the fees of the arbitrator and the reasonable attorneys' fees of the prevailing party. If either party petitions to confirm, correct or vacate the award as provided by Chapter 4 of Title 9 of the California Code of Civil Procedure (commencing with Section 1285), the prevailing party shall be entitled as part of his or its costs to reasonable attorneys' fees to be fixed by the Court.

**21. JURISDICTION, FORUM AND VENUE.**

Except as otherwise required by Section 20 of this Agreement concerning dispute resolution, the proper jurisdiction, forum and venue for any claims, causes of action or other proceedings concerning this Agreement shall be in the state and federal courts located in the State of California, County of San Diego. The DISTRICT and SPECIALIST

agree not to bring any action or proceeding arising out of or relating to this Agreement in any other jurisdiction, forum or venue. The DISTRICT and SPECIALIST hereby submit to personal jurisdiction in the State of California for the enforcement of this Agreement and hereby waive any and all personal rights under the law of any state to object to jurisdiction within the State of California for the purposes of any legal action or proceeding to enforce this Agreement whether on grounds of inconvenient forum or otherwise.

**22. MAILING ADDRESSES.**

Notices given pursuant to this Agreement shall be deemed communicated as of the earlier of the day of receipt or the fifth (5<sup>th</sup>) calendar day after deposit in the United States mail, postage prepaid, and addressed to the following:

**DISTRICT: Rainbow Municipal Water District  
3707 Old Hwy 395  
Fallbrook, CA 92028  
Phone: (760) 728-1178**

**SPECIALIST: Kinsey & Kinsey, Inc.  
26 N. Park Blvd.  
Glen Ellyn, IL 60137  
Phone: (630) 858-4866**

Notices delivered personally will be deemed communicated as of actual receipt.

**23. SIGNATURES.**

Each party represents and warrants that the individual executing this Agreement on its behalf has the right, power, legal capacity and authority to enter into and to execute this Agreement on behalf of such party.

**24. COUNTERPARTS.**

This Agreement may be executed in counterparts, each of which shall constitute an original, but all of which together shall constitute one and the same agreement, and the signature of any party to any counterpart shall be deemed to be a signature to, and may be appended to, any other counterpart.

**25. ATTORNEYS' FEES.**

In the event of a dispute arising under terms of this Agreement, it is agreed that the prevailing party may be awarded reasonable attorneys' fees and actual costs.

IN WITNESS WHEREOF the parties hereto for themselves, their heirs, executors, administrators, successors, and assigns do hereby agree to the full performance of the covenants herein contained and have caused this Agreement to be executed.

**Kinsey and Kinsey Inc**

**RAINBOW MUNICIPAL WATER DISTRICT**

By \_\_\_\_\_  
**SPECIALIST**

\_\_\_\_\_  
PRINT NAME

Date: \_\_\_\_\_

\_\_\_\_\_  
Federal Employee ID #

By \_\_\_\_\_  
**GENERAL MANAGER**

Date: \_\_\_\_\_

\_\_\_\_\_  
Attest: Executive Secretary

\_\_\_\_\_  
Approved as to Form:  
General Counsel

**NOTARY ACKNOWLEDGEMENT OF SPECIALIST MUST ACCOMPANY THIS DOCUMENT**

**EXHIBIT A**







Proposal for  
**Rainbow Municipal Water District**

**Infor Lawson CloudSuite Financials &  
Supply Management Implementation**

Submitted by Kinsey & Kinsey, Inc. (Kinsey)  
April 16, 2018

**Kinsey Proposal Contact:**

Brad Kinsey, CEO

Office: (630) 858-4866 · Mobile: (630) 913-2343

Email: [b.kinsey@kinsey.com](mailto:b.kinsey@kinsey.com)

[www.kinsey.com](http://www.kinsey.com)

26 North Park Boulevard

Glen Ellyn, IL 60137

---

## Table of Contents

<b>Introduction.....</b>	<b>1</b>
<b>Statement of Experience .....</b>	<b>2</b>
<b>Project Specifics .....</b>	<b>4</b>
<b>Pricing.....</b>	<b>20</b>

---

## Introduction

April 16, 2018

Mr. Tom Kennedy  
General Manager  
Rainbow Municipal Water District  
3707 Old Highway 395  
Fallbrook, CA 92028

Dear Tom:

Kinsey & Kinsey, Inc. (“Kinsey”), as a long time Lawson and Infor partner, is pleased to offer this proposal for implementation of the Infor Lawson CloudSuite Financials and Supply Management Software to the Rainbow Municipal Water District (“RMWD” or “District”).

Kinsey is a full-service solution provider of application software and consulting services with a specific focus on the Public Sector. The company specializes in ERP application implementation and integration, and since 1983 has provided clients a broad range of expertise in the areas of financials, procurement, human resources, payroll, budgeting, and analytics. Kinsey has been an Infor Lawson partner since 1997. System consultants and application experts consistently deliver results that exceed expectations.

On behalf of Kinsey, thank you for the opportunity to provide this proposal. We would certainly be happy to answer any questions you may have and we would welcome the opportunity to establish a long-term partnership.

Sincerely,

  
Bradley J. Kinsey, CEO

---

## Statement of Experience

Kinsey has been a certified Infor / Lawson partner since 1997 and has twice been recognized by Lawson as “Partner of the Year”. Since 2000, at the request of and in partnership with Lawson, the firm has developed significant experience and expertise with the Public Sector. With a streamlined, Lawson-based implementation methodology, the company regularly delivers implementations for medium-sized businesses at a fraction of the cost of larger and more process-bound service providers. All consultants are trained and certified by Lawson, and on-site training builds on standard Lawson reference materials.

Utilizing senior consulting talent in a joint role of consultant and project manager streamlines communications and removes a layer of redundant reporting. This approach has led to exceptionally high client satisfaction and realized value.

Kinsey implements the full Infor Lawson set of applications, with relationships with independent contractors and other partners for other Infor public sector related functionality (Workforce Management, Enterprise Asset Management & Hansen permitting, utility billing, specifically). Kinsey has exceptionally strong experience with Infor Security, including advanced security reporting and segregation of duties deliverables. Kinsey has provided security upgrades from the legacy LAUA security to Lawson Security 9 (and 10) for over 50 clients.

Functional consulting has been the key part of the Kinsey practice, but the company has strong technical talent on staff. Three employees have previously worked as system administrators at Lawson clients. And while Kinsey has worked hard to help clients deploy the software without customizations, the firm is very capable of providing and supporting custom enhancements where needed.

Since 2000, at the request of and in partnership with Lawson, Kinsey has developed significant experience and expertise with the public sector, and the firm has worked with many Infor Lawson public sector clients. All consultants are trained and certified by Lawson, and on-site training builds on standard Lawson reference materials. Clients include:

Albuquerque Public Schools  
Arlington, TX  
Atlanta Public Schools  
Avondale, AZ  
Boulder Valley (CO) Schools  
Calvert Authority (MD) Schools  
Carlsbad, CA  
Chicago Housing Authority  
Chugach, AK

Juneau, AK  
**Milwaukee Metro Sewer District**  
Naperville (IL) Schools  
**Northern Colorado Water**  
PA Office of the Attorney General  
Pasadena ISD (TX)  
Racine Public Schools (WI)  
Roanoke, VA  
Rochester Genesee Transportation Authority

CO Springs Utilities  
Denver Public Schools  
**District of Columbia Water**  
District 300 Schools ( IL)  
DuPage Authority, IL  
Effingham (IL) Schools  
Great River Energy  
Guilford Authority, NC  
Indian Prairie (IL) Schools

Shakopee (MN) Public Schools  
Southern Maryland Electrical Cooperative  
St. Charles, IL  
St. Louis Special Schools  
Tompkins Authority, NY  
**Western Municipal Water District (CA)**  
**West Basin Water (CA)**  
Woodstock (IL) Public Schools  
Yolo Authority CA

In addition, Kinsey acquired a complimentary product line in 2006, giving the company a Lawson-aware, Java-based, SOA-compliant set of integration and audit tools to better meet clients' needs in the areas of compliance and sophisticated connectivity. Solutions are available which add value to Lawson in the following areas:

- Security Reporting (both S3 and Landmark applications)
- Security Auditing
- Segregation of Duties (over 2000 rules delivered)
- Transaction Auditing

The company is based in suburban Chicago, currently employs 23, has annual sales of approximately \$4 million, and has been privately owned by its two founders (who remain active) since inception. In addition to Lawson, the company enjoys a strong partnership with Microsoft Business Solutions.

## Project Specifics

The Infor CloudSuite Financials and Supply Management solution delivers an exceptionally full set of application modules.

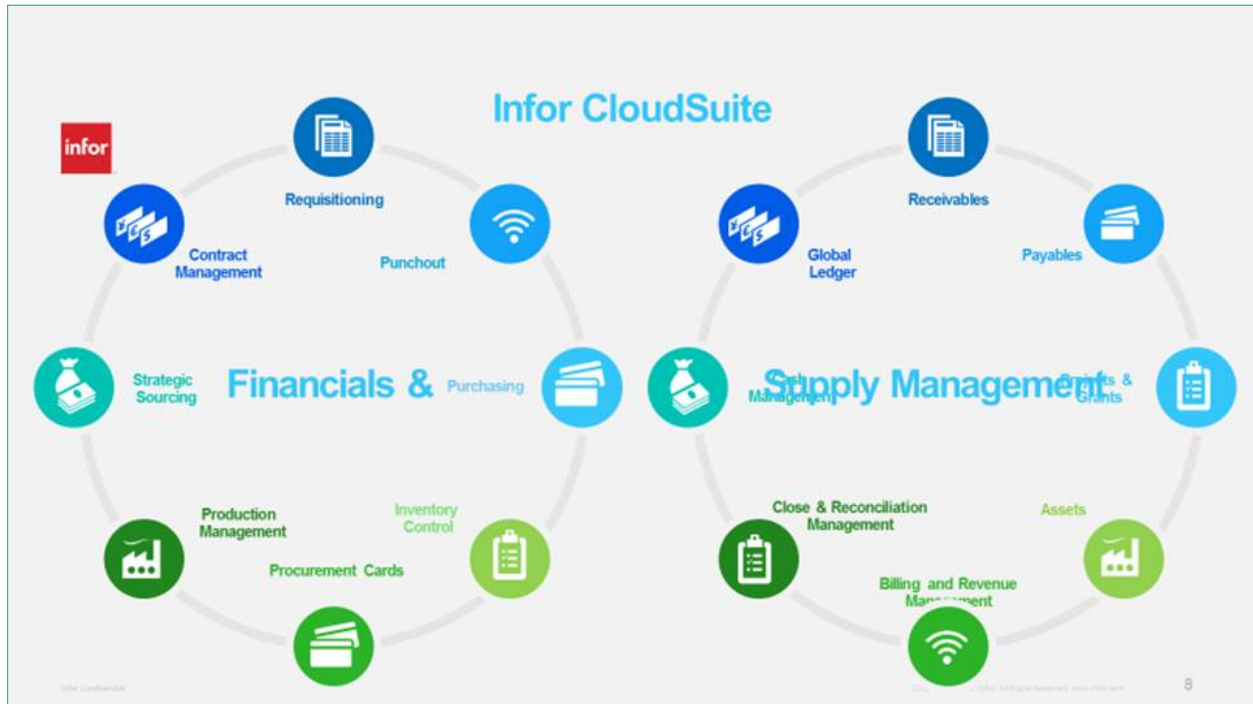

Kinsey understands that RMWD is interested in implementing only a core set of applications at this time, including:

- General Ledger
- Accounts Payable
- Asset Management

Infor's workflow tool, Infor Process Automation ("IPA"), will be deployed to automate the most effectively addressed business processes (40 hours dedicated to IPA). This will provide RMWD with exposure to the tool, and over the long-term RMWD will likely use it extensively. The other delivered utility which will be introduced is the Infor Spreadsheet Designer; this is a delivered MS Excel and Word plug-in which will be used for data loading and also ad hoc reporting. Over time, the additional modules should provide RMWD with opportunities for greater use of the software; the requisition and inventory modules frequently provide a good rate of return on the implementation investment.

As noted above, for projects which do not require fulltime project management, Kinsey utilizes senior consulting talent in a joint role of consultant and project manager. This streamlines communications and removes a layer of redundant reporting and has led to exceptionally high

client satisfaction and realized value. Mike Oswald, one of Kinsey's most experienced and well-regarded consultants, will serve in the dual role of project manager and functional consultant.

## Michael P. Oswald

### Certifications

**Lawson Certified in Financial and Procurement Applications**  
**CPA Certificate – Illinois, 1983**

### 1997 – Present

**Kinsey & Kinsey, Inc., Glen Ellyn, IL**  
**Senior Product Consultant**

Responsible for assisting clients in plan development and implementation of Lawson software. Implementation services range from hands-on functional consulting to project management. Lawson clients include: Waukesha Memorial Hospital, Tilly's, Naperville Consolidated Schools (IL), Indian Prairie Public Schools (IL), Carpentersville Public Schools (IL), New Hanover Regional Medical Center (NC), Woodstock Community Schools (IL), Shakopee Community Schools (MN), ProHealth Care, Central DuPage Health, DeVry Institute, Follett College Stores, Greenville Hospital (SC), Rush Prudential Health (IL), West Basin Water District, Western Municipal Water District, St. Vincent's Hospital (IN), the City of St. Charles, IL, the City and Borough of Juneau, AK, DuPage County, IL, District 211 Schools, IL., and Yolo County, CA.

### 1986 – 1997

**The Color Company, Elk Grove Village, IL**  
**Chief Financial Officer**

Graphics arts service company that provides pre-press services to clients ranging from publications to agency work. Responsible for overall operations as well as accounting functions.

### 1983 – 1986

**Alumni Holidays, Inc., Des Plaines, IL**  
**Controller**

Responsible for daily operations of this group and incentive travel company: general ledger including preparation and analysis of consolidated financial statements, staff supervision, review of journal entries, preparation of federal and state tax returns.

### 1981 – 1983

**Arthur Young & Co., Chicago, IL**  
**Staff Accountant**

Responsible for audit and tax work on a variety of clients ranging from not-for-profit to manufacturing and small privately held firms to Fortune 500 companies. Duties included evaluation and recommendations of internal controls, preparation of year-end journal entries, preparation of individual and corporate tax returns.

### Education

**St. Norbert College, De Pere, WI**  
B.B.A., Accounting

To keep travel expenses to a minimum, it is anticipated that the project will be divided equally between on-site and remote work. In addition, because the utility billing implementation is also in process, the project will be a half-time endeavor, at least until the utility billing project is completed. This hopefully will allow adequate District staff time to be dedicated to the ERP project.

The Infor CloudSuite implementation will be a coordinated project jointly managed by Kinsey and the District; Kinsey will assign a Project manager to work closely with the RMWD's Project Manager. It is understood that RMWD will also appoint a Steering Committee consisting of the District's project manager and the project leads for finance, procurement, and information technology, with the RMWD executive sponsor attending as schedules allow.

The Kinsey project manager will create and maintain a detailed Project Plan, and also an Issues Log which will identify implementation problems, identify the person(s) responsible for resolution, and identify the agreed upon target completion dates.

Standard procedures call for regular Steering Committee meetings to ensure that management remains involved with the project and aware of all issues. The Kinsey PM will provide a status update of the project plan, including a review the preceding week's work, and also a preview the forthcoming week's work. The issues log will be reviewed and updated. Change management issues will be discussed as brought forward by management.

RMWD should have technical staff attend at least 2 Infor technical classes: the 5 day system administration class and the 4 day security class. The Infor Process Automation class is recommended as well, but the Kinsey technical consultants should be able to provide enough on-site knowledge transfer for the District to do basic IPA work without the class.

The project will start with a CloudSuite readiness assessment to validate and confirm the Infor provisioning.

After the readiness assessment is completed, the following project plan will be deployed for the application implementation:

### **1.1 – Kick Off Meeting / Project Plan Development**

The kick-off meeting is the official start to establishing the project objectives, direction, introduce the Implementation Methodology, review the preliminary project plan, and establish a team approach to achieve a successful implementation.

#### **Objective:**

This is a critical step. It is crucial to the success of the implementation that certain information is obtained and agreed upon:

- Commitment



- Project Scope and Goals
- Roles & responsibilities

Critical components to developing a successful Project Plan include:

- Milestones
- Critical Dates
- Project Constraints
- Critical Business Issues

The first draft of the project schedule is reviewed. Revisions will likely be required in the forthcoming weeks. The initial schedule documents mission critical tasks required to implement the product and it attempts to assign a realistic time frame to the project tasks. Kinsey will provide a line item project plan template (without dates) corresponding to this statement of work in Microsoft Excel (or other mutually agreed-upon format) which the Steering Committee will use to complete a draft Project Plan. The project activities will thereafter be updated by Kinsey and managed by all responsible parties against this project plan for the duration of the implementation.

The Project Plan may be updated to incorporate detailed activities that are not included in this SOW for each task. For example, the procurement implementation could include review of the processes for the development of Purchase Order creation, issue, and receipt, for the various types of Purchase Orders. Although these details are not documented in this SOW, the intent of all of these processes is to configure, test, and go live with all of the basic capabilities. It is understood that the Project Plan will be a working document and it is expected that changes will be made over time.

### **Deliverables to the Project:**

#### **Kinsey**

- Strategy Meeting agenda
- Meeting Facilitation
- Draft Project Plan (Schedule)
- Issue tracking log Template
- Project Training Plan
- Software Installation Completion Report

#### **RMWD**

- List of Critical Business Issues
- List of Application Business Objectives
- Steering Committee identified
- Project Plan Review

### **1.2 – Current State / Future State Analysis**

The Project Team needs to agree on how the business currently operates and then prioritize the Lawson functionality to be deployed. This step requires review and

documentation of the District's critical work flows. Kinsey consultants will introduce Lawson best practices and develop consensus on "To-Be" specifics for the implementation.

**Objective:**

The goal of this activity is to establish a base line for the implementation tasks. That is because some analysis of business requirements was used in the software selection process. As a first step, the implementation team will confirm the critical business issues established in the sales cycle. The team will formalize the project's scope and goals, establish the project standards and develop the application business objectives.

A second step is to identify current business practices. Identifying current business practices and procedures is a significant forerunner to determining how to implement these processes into the Lawson framework. Before the Project Team begins to develop new procedures, they want to identify obsolete and outdated practices, as well as ones that are working well. The goal of the implementation project is not to change how the District does business, but rather, where possible, to improve it.

For the very reason that new software requires new procedures, few team members want to put a lot of effort into documenting old systems. Everyone is eager to start on the 'new' systems; however, the time taken here is normally more than recovered in later activities. For instance, development meetings are more productive when everyone has previously agreed on how the current systems work and what is to be kept. In the design phase, the team members will address the new procedures. The deliverables from this activity provide a starting point.

When examining current business practices, all of the departments that will be affected by the application(s) being implemented need to be considered. A review of all the major functions within the departments will be completed and documented. Given the resource-intensive schedule to go live, procedures will be prioritized based on crucial business functions and complexity. This will become a working document that the District can translate into CRP scripts, new procedure manuals and training guides.

It is this step that will set the target deliverables for the project. Not all of the software's capabilities will be deployed in the initial implementation; Lawson is an exceptionally robust application and it can be expected that new features will be deployed on an ongoing basis. The goal of this initial project is to deliver the functionality that will provide Rainbow Municipal Water District with the greatest possible return on the implementation investment. Kinsey consultants understand where these returns typically accrue in a public sector environment, but with sensitivity to the specific needs and opportunities at the District, they will direct the identification

of the appropriate set of future state deliverables that take all of these factors into account.

**Deliverables to the Project:**

**Kinsey**

Current State / Future State documentation

**RMWD**

The District should be looking at who uses the reports or forms. What is the volume of transactions? Are there files that should be cleaned up? Can the process be improved?

Current user process flows

Current system flows

Copies of reports, forms and screens

List of current interfaces

List of Application of Business Objectives

List of Critical Business Issues

**1.3 – Outline conversion and interface plans**

The Steering Committee needs to define all of the interfaces that will be required and the legacy data that will be converted so that adequate time may be scheduled for these functions.

**Objective:**

The goal of this activity is to identify the interfaces and determine the responsibilities of the specific team members that will be involved in the interface creation. In addition, the data conversions will be defined. It is understood that additional resources will be made available to assist with the harvesting of the legacy data. The team will document the requirements for the conversions and interfaces and the technical members will begin writing some of the programs, as needed.

**Deliverables to the Project:**

**Kinsey**

Meeting facilitation

Introduction of Lawson API's

Review of standard data conversion process and issues

**RMWD**

The District should include the technical resources that will be available for the project and be prepared to assist in determining where skills may need to be supplemented by Kinsey or other outside resources.

Knowledge of applications to be interfaced

Knowledge of legacy data to be converted

Understanding of the amount of data to be converted (3 years GL, 2 years purchase history, etc.)

**2.1 – Functional Application Training**

Functional training will be provided by Kinsey at the District’s facilities. In the classroom the implementation team members (and potentially other end users) learn about system set up, features, and processing flow. Kinsey will utilize standard Lawson user guides, but use them selectively, tailoring the training to the District’s specific needs and interests.

In addition to the training outlined below, the MS-Addins will be trained on-site as needed, and Process Flows will be trained as provided in an informal hands-on, cooperative process.

Technical training will be provided in Lawson public classes; these are held in Lawson locations throughout the US.

**Objective:**

Provide training to the Project Team to allow them to make setup and procedural decisions and identify potential issues

**Education Deliverables to the Project:**

**Private Education provided by Kinsey (at a District site with District resources, 12 person limit):**

***Financial Training***

General Ledger – 3 days	
Accounts Payable – 2 days	
Asset Management – 2 days	
Purchase Order – 2 days	
Invoice Matching – 1 day	
<b>Total Private Education</b>	<b>10 days</b>

**Public Education provided & billed by Lawson (per person at \$900 per day):**

***Technical Training***

System Admin (two persons) – 5 days	
Security Administration – 4 days	
Infor Process Automation (recommended) – 4 days	
<b>Total Public Education</b>	<b>13 days</b>

**2.2 - Application Exploration**

After training is completed, the users must spend time on the system at their site. The team uses this time to understand how the basic Lawson system works. With this hands-on experience, the team can assist with the design of how their business process will integrate with Lawson.

**Objective:**

This activity occurs after the District completes a Lawson training course. The purpose is for the team members to experiment with the functions available in an application and reinforce the concepts they learned in class.

With a thorough understanding of the basic applications, the team can confidently decide how Lawson is to be incorporated into the business. Despite the training materials and classroom instruction, most people cannot remember all the details from class. Neither can the instructors cover every nuance of the applications. Therefore, it is important that the team make the time to get onto the system and experiment. This initial exploration is supported by standard test data delivered by Lawson and will have been previously installed. While the sample data is not that of a similar operation, experience has shown it to be adequate for the limited purpose of application exploration.

Activities for the District's team include; unit testing, investigating the results of the setup parameters and procedure documentation. Kinsey will work with the team after training to help reinforce the concepts.

**Deliverables to the Project**

**Kinsey**

Consultants

**RMWD**

Current Business Workflows

Setup Parameter Documentation

**2.3 – Build Setup Parameters**

Upon completion of training and application exploration, the Project Team will begin defining how Lawson will work for the District. **This is the primary design component of the project.** The general ledger chart of accounts will be set, project and grant parameters will be identified, and the procurement process will be defined. In HR and payroll the employee groups and pay classes will be defined. In this step the Project Team actually constructs the basic system structure, defines master files and identifies user-defined fields. Lawson typically provides a number of options for getting to a specific end; this step includes an exploration of those options and decisions on deployment.

**Objective:**

The goal is to get to the full functionality desired in the most simple means possible – “Simpler is Better”. Where processes can be streamlined, they will be streamlined.

Where more complex processes are required to better deal with specific issues, these processes will be delivered.

### **Deliverables to the Project**

#### **Kinsey**

- Consultants
- Setup Parameter Documentation

#### **RMWD**

- Current Business Workflows

### **2.4 – Script preparation for conference room pilot**

The team writes the CRP scripts now. Kinsey consultants will provide sample scripts for generic functions, but the scripts that are of most value will be those defined by the District which reflect the specific challenges which their operating environment presents. The difficult and odd-ball scenarios are the ones that will best test the setup and facilitate knowledge transfer.

#### **Objective:**

The scripts should be written in enough detail so that when all have been successfully executed there should be confidence in the setup and a significant amount of knowledge transfer to the core team. This is both a system test and an important training event.

The bulk of the time invested here will be that of the District staff, and the District has the primary responsibility for the scripts creation. The scripts are an outline of the steps they would do to complete a business procedure. Procedures like producing a check or gathering the data to enter and verify a batch. The basis for the scripts will be the decisions made and documented during the Business Procedure Review. Scripts can also be utilized as the basis for a Procedure Manual.

### **Deliverables to the Project**

#### **Kinsey**

- Sample scripts
- Application and Technical Consulting

#### **RMWD**

- Actual operating scenarios, especially those that have been problematic

### **2.5 – Review and clean-up legacy data**

The purpose of this activity is to ensure that duplicate and erroneous data is scrubbed, purged, and consolidated as appropriate prior to converting and loading into Lawson.

**Objective:**

Live data will be incorporated into the conference room pilot. Data clean-up can be a very big endeavor. Good work on the front-end will preclude a lot of reworking of conversion processes. Because the District knows and owns the data, ultimately the District must bear the responsibility to ensure that it is accurate.

**Deliverables to the Project**

**Kinsey**

Project Planning Consulting  
MS Add-in instruction & examples to facilitate data review via Excel

**RMWD**

Significant time and effort to get legacy data into a pristine condition

**2.6 – Process flow, dashboards & report development**

This activity will result in the design, development and delivery of District-specific functionality available through the Infor Process Automation.

**Objective:**

Process flows will be developed to automate chain processes. Frequent applications include the routing of purchase orders and general ledger entries for approval. Role-specific dashboards will be delivered to provide custom views of the Lawson environment.

**Deliverables to the Project**

**Kinsey**

Design specifications  
Draft and work-in-process checks  
Final Infor Process Automation output

**RMWD**

Sample reports  
Business process flow diagrams

**3.1 - Data Conversion and Interfaces**

As part of the Business Needs Analysis, conversions and interfaces will have been identified and resources assigned to complete them. It is generally desirable to complete them sooner rather than later in the project. If not completed prior to System Testing, this will be the time when they must be ready for testing. Lawson provides interface programs for a number of data areas. Kinsey will provide assistance in mapping, preparing and testing the required programs. And while Kinsey can assist in data validation, the data ultimately is that of the District and the District must take responsibility for the accuracy of same.

## **Deliverables to the Project**

### **Kinsey**

- Assistance with data conversion
- Legacy data mapped to Lawson applications
- Lawson Data Extraction Processing/Interface Configuration/Development

### **RMWD**

- Assistance with data conversion
- Legacy data identified, provided in an acceptable format (Excel preferred)
- Data cleansing completed

## **3.2 - Conference Room Pilot Testing**

The conference room pilot enhances the Project Team's understanding of Lawson applications. The goal is to assure that the planned implementation effectively addresses the District's business issues and validates decisions made on set up and procedures in a hands-on environment. The CRP is performed using a small controlled set of data. Kinsey will lead the RMWD staff through the execution of the conference room pilot.

### **Objective:**

The objective is to use the Lawson Software applications after training and application exploration and initial data conversion is complete in order to enhance understanding, verify assumptions made concerning functionality, fit, enhancements, interfaces and business practices. After the training is completed, the Project Team prepares test scripts to perform during the CRP. The tests will use a small controlled set of data that is representative of normal processing. The Project Team then conducts the CRP to evaluate progress, address issues that have arisen, and review plans and schedules.

During the Conference Room Pilot, issues will arise. Unexpected results normally occur and sometimes a new script will be required. It is important to document the issues on the Issue Log as they are identified. The Issue Log will include the name of the resource assigned to find a resolution and a targeted date for completion.

During the Conference Room Pilot there will undoubtedly be issues surface that require a change in the system setup to remedy. Such changes will be made contemporaneously and all affected scripts will be rerun in order to get to desired results. This can be a very iterative process.

At the completion of the Conference Room Pilot, the Project Team should be prepared with responsibilities, policies, procedures, task lists, decisions to be made, issues to be resolved, and interfaces, enhancements, or modifications needed to take the applications into production.



CRP cannot take the place of training, but it should greatly accelerate and enhance the learning process. This should not be the first time the Project Team members have signed onto the system. Involvement of all the members of the project is crucial.

### **Deliverables to the Project**

#### **Kinsey**

- Consulting
- Sample scripts and assistance with creating custom scripts
- Maintain issues log

#### **RMWD**

- CRP Scripts, including difficult actual scenarios
- Issue Forms
- Updates to Procedure Manuals
- Perform the CRP testing

### **3.3 –Review Reports, Train Ad Hoc Reporting**

The CRP will produce results that can be analyzed with the standard Lawson reports most of which can be run in a variety of ways depending on the selection criteria used. Where standard reports don't seem to measure up to the requirement, ad hoc reporting with the MS Add-ins will be explored, and failing this, custom Crystal reports can be developed.

### **Deliverables to the Project**

#### **Kinsey**

- Consulting
- Standard report and assistance with creating ad hoc reports

#### **RMWD**

- Legacy reports
- Issue descriptions

### **4.1 - Acceptance Test**

This is the final test of the whole system (including conversions, interfaces and modifications) prior to the final cut-over to production. A test plan will be developed jointly to ensure that adequate and complete testing is completed. Because this function is site-specific, varying with setup decisions, conversions and interfaces, this plan cannot be developed much earlier in the process.

#### **Objective:**

It is now “show time” and this is the final opportunity to determine if any show stoppers exist. Several earlier steps in the methodology have included testing such as application

exploration and CRP. Now is the time to put it all together: conversions, interfaces, and volume. This also serves as an opportunity to review the hardware, database, operating systems and security. (Note: Security testing, depending on the desired level of security, identification and setup of security will have already been completed.)

System tests come in three basic formats; scripted, parallel, and modified (subset of actual) parallel. It is expected that parallel testing will be utilized for payroll, but that with other applications it is anticipated that a rerunning of CRP scripts and tie-outs of Lawson reports to legacy reports for open subledgers (open AP invoices, open PO's, inventory counts and valuations, fixed asset details, GL ledger, etc.) will serve as final test criteria. The Steering Committee may establish an alternative set of mutually agreeable criteria.

**Deliverables to the Project:**

**Kinsey**

- Test Plan
- Problem resolution Facilitation
- Consulting

**RMWD**

- Test execution
- Updates to Issue Log

**5.1 - End User Training**

The people who will be using the new system must be trained on the new system as well as the any procedures before GO LIVE. It is expected that District personnel will be able to lead this training with support from Kinsey. Given the small size of the RWMD staff, this will likely not require a significant time.

**Objective:**

The objective of this step is to train the users so they are capable of performing their job responsibilities using Lawson applications.

It is human nature to resist change. The resistance and stress can be minimized by providing project updates to the user base early and often. Upper management must communicate the need and value proposition for putting in a new system prior to the start of training.

**Deliverables to the Project:**

**Kinsey**

- Training Material
- Instructor support

## **RMWD**

Training Material  
Instructors

### **5.2 – Final Data Conversion and Clean-up**

Prior to live processing the final round of data conversion will be completed. Reports will be run from Lawson and verified against corresponding reports from the legacy systems.

#### **Objective:**

This step must be completed successfully before live processing can begin. This will ensure that the Lawson system will continue from the exact place that the legacy system end.

#### **Deliverables to the Project**

##### **Kinsey**

Assistance with data conversion

##### **RMWD**

Data conversion

Legacy data identified, provided in an acceptable format (Excel preferred)

Data cleansing completed

### **5.3 - Readiness Assessment**

The readiness assessment takes place just prior to the scheduled GO LIVE date. The purpose is to review the implementation plan and verify all tasks are complete. Also, review the end user training to insure end user acceptance of the system.

#### **Objective:**

This step includes a meeting, but like the other activities in the methodology, more tasks are involved. The meeting is held prior to GO LIVE to identify and prioritize incomplete tasks, review end-user feedback and ensure acceptance of the system. At this time a decision must be made to go into production as scheduled or consider a delay. If the decision is to move forward, then a second objective is to develop and/or complete the cut-over plan.

Other activities associated with this phase are final conversions, completion of open issues and communication to all vendors and customers of the impending changes. Some of the technical activities that will need to be completed include; activating security, developing a system backup schedule, and finalizing the disaster recovery plan. A contingency plan should be developed in the event that live processing is delayed.

**Deliverables to the Project:**

**Kinsey**

- Meeting Facilitation
- Readiness Assessment
- Inputs to Completed Implementation Plan
- Inputs to Contingency Plan
- Production Cutover Plan

**RMWD**

- Completed Implementation Plan
- Contingency Plan

**5.4 - Production – Go Live**

This is the completion of the tasks to GO-LIVE.

**Objective:**

Production (GO-LIVE) is the execution of a series of procedures, not just a single event. In other words, 'live' is not the day after the readiness meeting when everyone decided to go live. The Production activities include; the final conversion, the first time record entered, the first invoice run, the first closing, etc. The status of 'going into production' lasts until the users perform all their jobs confidently and efficiently.

**Deliverables to the Project:**

- Kinsey Consultants
- Lawson Help-desk introduction

**RMWD**

- Live Function System

**6.1 - Post Implementation Support, Closing & Reporting**

Kinsey consultants will typically be available for 6 weeks after go-live in order to support the first full month of live processing and the completion of month-end reporting and closing procedures.

**Objective:**

This step provides closure for the implementation and a transition to Infor Xtreme Support. A final Post Implementation Audit/Review is used to identify any features and procedures that were deferred to meet deadlines. Review procedures for additional improvements.

**Deliverables to the Project:**

**Kinsey**

Post Implementation Review and support

On-site support

Consultants' findings

**RMWD**

Running the new system with an open mind and with an understanding that processes that initially seem difficult will become second nature over time

## Pricing

Kinsey will provide services at a rate of \$160 per hour. All work is provided on a time and material basis and direct travel expenses will be billed at cost. Kinsey will work to honor all of the Authority's travel policies.

Below is a preliminary breakdown of project hours by application / function:

<b>4 Month Implementation &amp; 2 Weeks Post-Live Support</b>	<b>Hours</b>	<b>Cost</b>
<b>(Services provided @ \$160/hr.)</b>		
Project Management <sup>1</sup>	80	\$12,800
General Ledger <sup>1</sup>	240	\$38,400
Accounts Payable / Matching <sup>1</sup>	240	\$38,400
Asset Management <sup>1</sup>	80	\$12,800
Security Consulting <sup>2</sup>	60	\$9,600
Process Flows, Reports & Dashboards <sup>2</sup>	80	\$12,800
Data Conversion <sup>2</sup>	40	\$6,400
Interfaces <sup>2</sup>	40	\$6,400
Misc Tech Support <sup>2</sup>	120	\$19,200
<b>Subtotal</b>	<b>980</b>	<b>\$156,800</b>
Anticipated travel expenses (1/4 time on-site; 4 trips @ \$1750 per trip)		\$7,000
<b>Total Estimated Implementation Costs</b>		<b>\$163,800</b>

<sup>1</sup> The project management and functional consulting time may be distributed differently but will not exceed 640 hours without a mutually agreed upon change order.

<sup>2</sup> The time required for the technical components may be distributed differently but will not exceed 220 hours without a mutually agreed upon change order.

<sup>2</sup> The Cloud Readiness and miscellaneous technical support hours will hopefully not be required in full.

---

## BOARD OF DIRECTORS

May 22, 2018

---

### SUBJECT

DISCUSSION AND POSSIBLE ACTION TO APPROVE CONTRACT CHANGE ORDER FOR INSPECTION SERVICES FOR THE HORSE CREEK RIDGE DEVELOPMENT

### BACKGROUND

The Horse Creek Ridge Development which is located east of I-15 on Horse Ranch Creek Road is nearing completion of the construction of water and sewer improvements. The Water and Sewer Construction Agreements for the development were executed on November 17, 2016 and June 15, 2017. Construction began in December, 2016. District facilities include water and sewer pipelines, a sewer lift station, and pressure reducing station. The District improvements total over \$14 million dollars. The development consists of a total of 751 homes and a sports complex.

### DESCRIPTION

In 2015, the District entered into a professional services agreement with Hoch consulting for as needed construction inspection services including pipeline, pump station, and materials construction inspections, coordinating project planning, daily inspection reporting and deficiency lists. Two change orders were executed to extend the schedule of the agreement without changing the fee. As the Horse Creek Ridge development began construction, it was evident that the original contract would not be sufficient to cover the inspection services needed. In March 2017, the Board approved a change order to fund inspection services for a year of inspection services for the Horse Creek Ridge Construction. Hoch Consulting has been assisting the District with inspection services, has proven to be a valuable consultant, and are familiar with the work needed to complete the Horse Creek Ridge development. Attached is the proposal for a change order to cover the remaining inspections for the Horse Creek Ridge development. Completion of District Facilities is expected within 6 to 12 months.

### POLICY/STRATEGIC PLAN KEY FOCUS AREA

Strategic Focus Area One: Asset Management. Skilled inspection during the construction of facilities is essential to ensuring that the assets perform without issues through their entire design lifespan.

### BOARD OPTIONS/FISCAL IMPACTS

The developer has deposited inspection fees to the District that will cover all costs related to this contract. There is no budgetary impact to the District.

1. Authorize General Manager to execute change order #04 to the As-Needed Inspection Services contract with Hoch Consulting not to exceed \$67,750.
2. Direct staff to pursue other options for inspection services.

**STAFF RECOMMENDATION**

---

Staff recommends Option 1.



---

Michael Powers, P.E.  
Associate Engineer

05/22/2018





**Hoch Consulting**  
5675 Ruffin Road, Suite 305  
San Diego, CA 92123  
(tel.) 858-431-9767  
ahoch@hochconsulting.com  
www.hochconsulting.com

April 20, 2018

Mr. Ken Gerdes, P.E.  
Rainbow Municipal Water District  
3707 Old Hwy 395  
Fallbrook, CA 92028

Subject: Horse Creek Ridge - Amendment No. 1 Proposal

Dear Mr. Gerdes:

Hoch Consulting has been providing ongoing inspection services for Horse Creek Ridge Project. The nature of this project has required greater inspection effort to successfully complete than what was originally anticipated, primarily due to an extended project schedule caused by the inefficiencies by the contractor and the housing developer. Hoch Consulting is pleased to present this proposal for Amendment 1 to our contract to complete inspection services for this project. The following summarizes Hoch Consulting's proposed scope of services and budget for these services.

**Proposed Scope of Services:**

**Task 1: Construction Inspection**

Hoch Consulting will provide construction inspection for the purpose of determining compliance with RMWD standards and the technical provisions of the project drawings and specifications as indicated in the following subtasks:

*Task 1.1: Unit 1 - Field Inspection* – Unit 1 consists of the primary backbone streets within the Horse Creek Ridge Development, including Horse Ranch Creek Rd., Gold Palomino Way, Andalusian Way, and Friesian Way. Construction of underground utilities and related appurtenances in Unit 1 is complete, and Hoch Consulting has performed an initial punch list walkthrough inspection. Remaining work as part of this task includes performing inspections of three remaining irrigation services, two potable water services a final walkthrough inspection. Hoch Consulting assumed 1.5 additional hours to perform initial and final inspections of the remaining irrigation services, 1 additional hour to inspect remaining potable water services, and 8 additional hours to perform a final walkthrough inspection. Hoch Consulting estimates 10 additional hours to complete field inspections in Unit 1.

*Task 1.2: Unit 2 – R1 – Oakmont Field Inspection* – Unit 2 – R1- Oakmont is a housing tract consisting of 136 lots. Construction of underground utilities in Unit 2 is complete, and 57 potable water meters have been installed by RMWD. Remaining inspection work as part of this task

includes performing an initial and final inspection for the 79 remaining lots, inspection of 63 remaining sewer lateral connections, final inspection of hydrants, blow-offs and air-vacs, an initial punch list walkthrough inspection and a final walkthrough inspection. Hoch Consulting estimates a total of 52 additional hours to complete Unit 2 – R1 – Oakmont Field Inspections. Our estimate is based on the assumption of 0.2 hours to perform an initial inspection of water services and to request meters at each lot, 0.2 hours to perform a final inspection of water services and remove locks after the meters have been installed, 0.2 hours to perform a final inspection of each hydrant, blow-off and air-vac, 4 hours to perform an initial walkthrough inspection, and 4 hours to perform a final walk-through inspection.

Task 1.3: Unit 3 – R2 – Westbury Field Inspection – Unit 3 – R2 - Westbury is a housing tract consisting of 71 lots. Construction of underground utilities in Unit 3 is complete, and 36 potable water meters have been installed by RMWD. Remaining inspection work as part of this task includes performing an initial and final inspection for the 35 remaining lots, inspection of 27 remaining sewer lateral connections, final inspection of hydrants, blow-offs and air-vacs, an initial punch list walkthrough inspection and a final walkthrough inspection. Hoch Consulting estimates a total of 27 additional hours to complete Unit 3 – R2 – Westbury Field Inspections. Our estimate is based on the assumption of 0.2 hours to perform an initial inspection of water services and to request meters at each lot, 0.2 hours to perform a final inspection of water services and remove locks after the meters have been installed, 0.2 hours to perform a final inspection of each hydrant, blow-off and air-vac, 4 hours to perform an initial walkthrough inspection, and 4 hours to perform a final walk-through inspection.

Task 1.4: Unit 4 – R3 – Bridlegate Field Inspection – Unit 4 – R3 - Bridlegate is a housing tract consisting of 63 lots. Construction of underground utilities in Unit 4 is complete, and 39 potable water meters have been installed by RMWD. Remaining inspection work as part of this task includes performing an initial and final inspection for the 24 remaining lots, inspection of 24 remaining sewer lateral connections, final inspection of hydrants, blow-offs and air-vacs, an initial punch list walkthrough inspection and a final walkthrough inspection. Hoch Consulting estimates a total of 23 additional hours to complete Unit 4 – R3 – Bridlegate Field Inspections. Our estimate is based on the assumption of 0.2 hours to perform an initial inspection of water services and to request meters at each lot, 0.2 hours to perform a final inspection of water services and remove locks after the meters have been installed, 0.2 hours to perform a final inspection of each hydrant, blow-off and air-vac, 4 hours to perform an initial walkthrough inspection, and 4 hours to perform a final walk-through inspection.

Task 1.5: Unit 5 – R4 – Saratoga Field Inspection – Unit 5 – R4- Saratoga is a housing tract consisting of 123 lots. Construction of underground utilities in Unit 5 is complete, and 15 potable water meters have been installed by RMWD. Remaining inspection work as part of this task includes performing an initial and final inspections for the 107 remaining lots, inspection of 24 remaining sewer lateral connections, final inspection of hydrants, blow-offs and air-vacs, an initial punch list walkthrough inspection and a final walkthrough inspection. Hoch Consulting estimates a total of 89 additional hours to complete Unit 5 – R4 – Saratoga Field Inspections. Our estimate is based on the assumption of 0.2 hours to perform an initial inspection of water services and to request meters at each lot, 0.2 hours to perform a final inspection of water services and remove locks after the meters have been installed, 0.2 hours to perform a final inspection of each hydrant,

blow-off and air-vac, 8 hours to perform an initial walkthrough inspection, and 8 hours to perform a final walk-through inspection.

*Task 1.6: Unit 6 – R5 – Promontory Field Inspection* – Unit 6 – R5- Promontory is a housing tract consisting of 123 lots. Construction of underground utilities in Unit 6 is not complete, with 550 LF of sewer and potable water pipeline on Shetland Hills East scheduled to be installed later this month. Additionally, hydrostatic pressure testing, chlorine testing and bac-t sampling still needs to be conducted on about 500 LF of potable water pipeline on Bay Sable Ln. Remaining inspection work as part of this task includes performing an initial and final inspections for the 114 remaining lots, inspection of 153 remaining sewer lateral connections, final inspection of hydrants, blow-offs and air-vacs, an initial punch list walkthrough inspection and a final walkthrough inspection. Hoch Consulting estimates a total of 153 additional hours to complete Unit 5 – R4 – Saratoga Field Inspections. Our estimate is based on the assumption of 0.2 hours to perform an initial inspection of water services and to request meters for each lot, 0.2 hours to perform a final inspection of water services and remove locks at each lot after the meter has been installed, 0.2 hours to perform a final inspection of each hydrant, blow-off and air-vac, 8 hours to perform an initial walkthrough inspection, and 8 hours to perform a final walk-through inspection.

*Task 1.7: MF-1 – Brindle Pointe Field Inspection* - MF-1 Brindle Pointe is a multi-family housing tract consisting of 124 lots. Construction of underground utilities in MF-1 is complete and 8 service meters and 8 bypass meters have been installed by RMWD. Remaining inspection work as part of this task includes performing an initial and final inspection for the remaining 2 service meters and 2 bypass meters, inspection of 40 remaining sewer lateral connections, final inspections of hydrants, blow-offs and air-vacs, an initial walkthrough inspection, and a final walk-through inspection. Hoch Consulting estimates a total of 19 additional hours to complete MF-1 – Brindle Pointe field inspection. Our estimate is based on the assumption of 0.2 hours to perform an initial inspection of water services and to request meters, 0.2 hours to perform a final inspection of water services and remove locks, 0.2 hours to perform a final inspection of each hydrant, blow-off and air-vac, 4 hours to perform an initial walkthrough inspection, and 4 hours to perform a final walkthrough inspection.

*Task 1.8: MF-2 – Chaparral Pointe Field Inspection* – MF-2 Chaparral Pointe is a multi-family housing tract consisting of 86 lots. Construction of underground utilities in MF-2 is complete. Sewer air testing is not complete in MF-2 and the two service meters and two bypass meters still need to be installed. Remaining inspection work as part of this task includes performing an initial and final inspection for the remaining two service meters and two bypass meters, inspection of 41 remaining sewer lateral connections, final inspections of hydrants, blow-offs and air-vacs, an initial walkthrough punch list inspection and a final walkthrough inspection. Hoch Consulting estimates a total of 17 additional hours to complete MF-2 Chaparral Pointe field inspection. Our estimate is based on the assumption of 0.2 hours to perform an initial inspection of water services and to request meters, 0.2 hours to perform a final inspection of water services and remove locks, 0.2 hours to perform a final inspection of each hydrant, blow-off and air-vac, 4 hours to perform an initial walkthrough inspection, and 4 hours to perform a final walkthrough inspection.

*Task 1.9: Sewer Lift Station* – Remaining work at the sewer lift station includes construction of CMU walls, vacuum testing of the influent manhole, asphalt concrete paving, installation of pumps and piping in the wet wells, installation of hose bibs and eyewash stations, installation of MCC and Panels, installation of the backup generator, start-up, testing, commissioning, punch-list, as-built drawings, and miscellaneous documentation. Hoch Consulting estimates a total of 132 additional hours to complete field inspections of the sewer lift station. A detailed estimate for inspection of remaining scope items is provided in the attached fee proposal.

**Schedule & Fee:**

Hoch Consulting proposes to perform the above scope of services on a time-and-material basis not to exceed an additional \$67,750, bringing the total fee for our services to \$346,970. A detailed summary of our estimate is provided in the attached fee proposal.

We greatly appreciate the opportunity to work for the Rainbow Municipal Water District. If you have any questions about this proposal, please do not hesitate to contact me.

Sincerely,  
HOCH CONSULTING

Adam Hoch, P.E., QSD  
President/Principal Engineer  
License No. C77635

Rainbow Municipal Water District  
Horse Creek Ridge  
Fee Proposal - Amendment No. 1

					TOTAL FEE
DESCRIPTION	Unit	Quantity	Hours per Unit	Inspector Evan Morrill	
				\$125	
<b>Task 1.1 - Unit 1 Field Inspection</b>				<b>11</b>	<b>\$ 1,313</b>
Irrigation Services	EA	3	0.5	1.5	\$ 187.50
Potable Water Services	EA	2	0.4	1	\$ 125.00
Final Walkthrough	LS	1	8	8	\$ 1,000.00
<b>Task 1.2 - Unit 2 - R1 - Oakmont Field Inspection</b>				<b>52</b>	<b>\$ 6,538</b>
Potable Water Services	EA	79			\$ -
Initial Inspection and Meter Request	EA	79	0.2	15.8	\$ 1,975.00
Final Inspection and Lock Removal	EA	79	0.2	15.8	\$ 1,975.00
Sewer Laterals	EA	63	0.1	6.3	\$ 787.50
Hydrants/Blowoffs/Air Vacs	EA	32	0.2	6.4	\$ 800.00
Punchlist Walkthrough	LS	1	4	4	\$ 500.00
Final Walkthrough	LS	1	4	4	\$ 500.00
<b>Task 1.3 - Unit 3 - R2 - Westbury Field Inspection</b>				<b>27</b>	<b>\$ 3,413</b>
Potable Water Services	EA	35			\$ -
Initial Inspection and Meter Request	EA	35	0.2	7	\$ 875.00
Final Inspection and Lock Removal	EA	35	0.2	7	\$ 875.00
Sewer Laterals	EA	27	0.1	2.7	\$ 337.50
Hydrants/Blowoffs/Air Vacs	EA	13	0.2	2.6	\$ 325.00
Punchlist Walkthrough	LS	1	4	4	\$ 500.00
Final Walkthrough	LS	1	4	4	\$ 500.00
<b>Task 1.4 - Unit 4 - R3 - Bridlegate Field Inspection</b>				<b>23</b>	<b>\$ 2,825</b>
Potable Water Services	EA	24			\$ -
Initial Inspection and Meter Request	EA	24	0.2	4.8	\$ 600.00
Final Inspection and Lock Removal	EA	24	0.2	4.8	\$ 600.00
Sewer Laterals	EA	24	0.1	2.4	\$ 300.00
Hydrants/Blowoffs/Air Vacs	EA	13	0.2	2.6	\$ 325.00
Punch List Walkthrough	LS	1	4	4	\$ 500.00
Final Walkthrough	LS	1	4	4	\$ 500.00
<b>Task 1.5 - Unit 5 - R4 - Saratoga Field Inspection</b>				<b>89</b>	<b>\$ 11,113</b>
Potable Water Services	EA	107			\$ -
Initial Inspection and Meter Request	EA	107	0.2	21.4	\$ 2,675.00
Final Inspection and Lock Removal	EA	107	0.2	21.4	\$ 2,675.00
Sewer Laterals	EA	95	0.1	9.5	\$ 1,187.50
Hydrants/Blowoffs/Air Vacs	EA	58	0.2	11.6	\$ 1,450.00
Epoxy Line Manholes/Spark Testing	EA	9	1	9	\$ 1,125.00
Punchlist Walkthrough	LS	1	8	8	\$ 1,000.00
Final Walkthrough	LS	1	8	8	\$ 1,000.00
<b>Task 1.6 - Unit 6 - Promontory Field Inspection</b>				<b>153</b>	<b>\$ 19,113</b>
Potable Water Services Inspection for Meters	EA	114			\$ -
Initial Inspection and Meter Request	EA	114	0.2	22.8	\$ 2,850.00
Final Inspection and Lock Removal	EA	114	0.2	22.8	\$ 2,850.00
Sewer Laterals	EA	121	0.1	12.1	\$ 1,512.50
Hydrants/Blowoffs/Air Vacs	EA	6	0.2	1.2	\$ 150.00
Epoxy Line Manholes/Spark Testing	EA	2	1	2	\$ 250.00
Sewer Pipeline Installation (Shetland Hills East)	LF	550		0	\$ -
Excavation Inspection	LS	1	4	4	\$ 500.00
Pipeline Bedding Inspection	LS	1	4	4	\$ 500.00
Pipeline Installation Inspection	LS	1	12	12	\$ 1,500.00
Cast-In-Place Manhole Base Inspection	EA	5	1	5	\$ 625.00
Manhole Vacuum Testing	EA	5	1	5	\$ 625.00
Sewer Air Testing	LS	1	4	4	\$ 500.00
Sewer Mandrel Testing	LS	1	4	4	\$ 500.00
Potable Water Pipeline Installation (Shetland Hills East)	LF	550		0	\$ -
Excavation Inspection	LS	1	4	4	\$ 500.00
Pipeline Bedding Inspection	LS	1	2	2	\$ 250.00
Pipeline Installation Inspection	LS	1	12	12	\$ 1,500.00
Water Service Inspection	LS	1	4	4	\$ 500.00
Potable Water Pressure Testing	LS	1	4	4	\$ 500.00
Potable Water Chlorine Testing	LS	1	4	4	\$ 500.00

Rainbow Municipal Water District  
Horse Creek Ridge  
Fee Proposal - Amendment No. 1

Potable Water Bac-T Testing	LS	1	2	2	\$ 250.00
Potable Water Pressure Testing (Bay Sable)	LS	1	2	2	\$ 250.00
Potable Water Chlorine Testing (Bay Sable)	LS	1	2	2	\$ 250.00
Potable Water Bac-T Testing (Bay Sable)	LS	1	2	2	\$ 250.00
Punch List Walkthrough	LS	1	8	8	\$ 1,000.00
Final Walkthrough	LS	1	8	8	\$ 1,000.00
<b>Task 1.7 - MF-1 (Lot 148)</b>				<b>19</b>	<b>\$ 2,325</b>
Potable Water Services	EA	4			
Initial Inspection and Meter Request	EA	4	0.2	0.8	\$ 100.00
Final Inspection and Lock Removal	EA	4	0.2	0.8	\$ 100.00
Sewer Laterals	EA	40	0.1	4	\$ 500.00
Hydrants/Blowoffs/Air Vacs	EA	25	0.2	5	\$ 625.00
Punch List Walkthrough	LS	1	4	4	\$ 500.00
Final Walkthrough	LS	1	4	4	\$ 500.00
<b>Task 1.8 - MF-2 Chaparral Pointe Field Inspection</b>				<b>17</b>	<b>\$ 2,113</b>
Potable Water Services	EA	4			
Initial Inspection and Meter Request	EA	4	0.2	0.8	\$ 100.00
Final Inspection and Lock Removal	EA	4	0.2	0.8	\$ 100.00
Sewer Laterals	EA	41	0.1	4.1	\$ 512.50
Hydrants/Blowoffs/Air Vacs	EA	6	0.2	1.2	\$ 150.00
Sewer Air Testing (Retest of Two Alleys)	LS	1	2	2	\$ 250.00
Punch List Walkthrough	LS	1	4	4	\$ 500.00
Final Walk Through	LS	1	4	4	\$ 500.00
<b>Task 1.9 - Sewer Lift Station Field Inspection</b>				<b>132</b>	<b>\$ 19,000</b>
<b>Completion of Remaining Scope Items</b>					
CMU Walls/Gate	LS	1	16	16	\$ 2,000.00
Influent Manhole Vacuum Testing	LS	1	2	2	\$ 250.00
AC Paving	LS	1	8	8	\$ 1,000.00
Install Pumps/Piping in Wet Wells	LS	1	12	12	\$ 1,500.00
Hosebibs/Eyewash Stations	LS	1	4	4	\$ 500.00
MCC/Panel Installation	LS	1	6	6	\$ 750.00
Generator Installation	LS	1	4	4	\$ 500.00
Startup/Testing/Coordination/Commissioning	LS	1	80	80	\$ 10,000.00
Punchlist, As-built Drawings, Misc. Documentation	LS	1	20	20	\$ 2,500.00
<b>TOTAL</b>					<b>\$ 67,750</b>

### BOARD OF DIRECTORS

May 22, 2018

---

### SUBJECT

DISCUSSION AND POSSIBLE ACTION TO APPROVE AMENDMENT TO SEWER SERVICE AGREEMENT FOR THE PALOMAR NORTH EDUCATION CENTER

### BACKGROUND

Palomar College acquired property north of State Route 76 between Interstate 15 and Horse Ranch Creek Road in the mid 2000's for the purpose of constructing its North Education Center. The campus will ultimately provide education services to over 8,000 part-time students and faculty. The campus is scheduled to open in June 2018.

A Sewer Service Agreement was approved by Board action on April 24, 2018. The terms of the Agreement included a stipulation that Palomar could not discharge to the sewer system until the Horse Creek Lift Station (D.R. Horton) is completed, operational and accepted by the District. Connection to the Pala Mesa Sewer at I-15 is also required.

Palomar College has substantially completed the sewer main through its campus which will connect to and convey flow from the Pala Mesa sewer to the recently completed sewer main in Horse Ranch Creek Road. The connection has not been made yet due to on-site campus construction and the pending completion of the new lift station.

### DESCRIPTION

The classes for summer session are scheduled to begin in early June but the Lift Station will not be completed until late June/early July. Based on those schedules, Palomar has requested approval to discharge to the sewer system in Horse Ranch Creek Road which is conveyed to a temporary lift station near the permanent Lift Station. The temporary lift station was completed by D.R. Horton for the Horse Ridge Development, and has a capacity of up to 250 EDUs.

D.R. Horton consented to allowing the Palomar discharge to the temporary lift station pending District approval. Engineering calculations have been submitted for District review and include estimated residential plus additional Palomar flows (400 students) and the effect on the existing lift station and downstream District system. The calculations assume an occupancy of 252 dwelling units by July 2018, 400 students, and a peaking factor of 3.0. The resulting peak flow is 166,000 gpd or 116 gpm, requiring the purchase and installation of two new 3 hp pumps, each with a capacity of 140 gpm. The existing temporary lift station was designed to handle a minimum pumping rate of 120 gpm. The change to slightly larger pumps and small increase in flows will not adversely affect the operation of the temporary lift station or the downstream District system.

This Amendment to the Sewer Service Agreement includes additional conditions of approval prior to providing interim/temporary sewer service to the Campus such as payment of construction costs and District engineering and inspection fees, abandonment of existing sewer manholes not needed after connection to the Pala Mesa area (golf course) sewer, and construction cost sharing for two flow monitoring manholes constructed on campus.

### **POLICY/STRATEGIC PLAN KEY FOCUS AREA**

---

Strategic Focus Area Five: Customer Service. Amending the Sewer Service Agreement with Palomar College is important in serving the college community. The amendment ensures that the College has access to sewer service for its Summer session at no detriment to the District.

### **BOARD OPTIONS/FISCAL IMPACTS**

---

Once the College is open, the District will realize revenue from water and sewer monthly charges. District cost of approximately \$25,000 for reimbursement of flow monitoring manhole.

- 1) Approve the Amended Sewer Service Agreement which allows Palomar conditional approval to discharge to the District sewer system and the temporary lift station.
- 2) Provide other direction to staff.

### **STAFF RECOMMENDATION**

---

Staff recommends Option 1.



---

Ken Gerdes, P.E.  
Interim District Engineer

May 22, 2018





RAINBOW MUNICIPAL WATER DISTRICT  
3707 OLD HIGHWAY 395, FALLBROOK, CALIFORNIA 92028  
TEL (760 728-1178 • FAX (760) 728-2575

**AMENDMENT TO SEWER SERVICE AGREEMENT  
BY AND BETWEEN RAINBOW MUNICIPAL WATER DISTRICT  
AND PALOMAR COMMUNITY COLLEGE DISTRICT**

**NORTH EDUCATION CENTER SEWER EXTENSION  
RMWD PROJECT NO. 200-200026  
CONTRACT NO. 18-\_\_**

This Amendment (“Amendment”) to the Sewer Service Agreement (“Agreement”) approved by the Rainbow Municipal Water District Board of Directors action on April 24, 2018, is made on this \_\_\_\_ day of \_\_\_\_\_, 2018, by and between Rainbow Municipal Water District (“District”), a municipal water district organized under the Municipal Water District Law of 1911, and Palomar Community College District (“Palomar”). Each of District and Palomar are interchangeably referred to as “Party” to the Amendment herein, and are collectively referred to as “Parties”.

**RECITALS**

A. District is a municipal water district organized pursuant to California Water Code Section 71000 *et seq.* District provides water and sewer service to properties within its service area.

B. Palomar is the owner of the real property located in the County of San Diego, and within the District service area, as more particularly described and depicted as County of San Diego TM 5338-1, Assessor Parcel Number 108-120-55 (the “Palomar College Site”).

C. District and Palomar entered into a Sewer Service Agreement dated May \_\_, 2018 which allows for the discharge of sewage to District facilities upon completion of the D.R. Horton Sewer Lift Station and connection of the Pala Mesa Sewer to the Palomar Sewer Line.

D. Said Sewer Service Agreement estimates the completion of the Lift Station to be late June/early July 2018 and requires completion of the connection between the Pala Mesa and Palomar sewer lines within three weeks of completion of the lift station.

F. Palomar will begin classes for students in June, 2018 and, by letter dated April 17, 2018, requested sewer service for operation of the campus prior to the completion of the Lift Station and connection of the Pala Mesa Sewer to the Palomar Sewer Line.

G. District, Passerelle and D.R. Horton entered into a First Amendment to Amended and Restated Sewer Service Agreement (“First Amendment”) dated October 26, 2015 which identified property acquired by D.R. Horton from Passerelle and certain rights and obligations assigned to D.R. Horton related to the Amended and Restated Sewer Service Agreement (“Agreement”) dated December 6, 2012 between the District and Passerelle. Section 2.e. of the

First Amendment states that the District shall not provide capacity to any third party's property in District's sewer system such that District would be precluded from providing capacity to Passerelle or D.R. Horton EDUs.

H. In May 2017 plans for a temporary bypass sewer pumping system were prepared by Dexter Wilson Engineering, Inc. and approved by the District. The temporary pump system was designed to accommodate up to 250 dwelling units being constructed by D.R. Horton until the permanent Lift Station is accepted by the District and becomes operational. Palomar sewage generation was not included in the capacity of the temporary pump system.

I. D.R. Horton, in cooperation with Palomar, authorized use of the temporary lift station by email correspondence to the District dated April 19, 2018.

J. District has received and reviewed preliminary design calculations and proposed pump upgrades which verify adequate capacity is available in the temporary lift station system to accommodate initial summer session staff and student sewer discharge volume without impact to the downstream District system.

### **AGREEMENT**

NOW, THEREFORE, for valuable and sufficient consideration, as condition of approval to temporarily discharge Palomar sewage to the sewer system and temporary lift station until the permanent D.R. Horton (Horse Creek) Lift Station is accepted by the District for operation, the Parties hereby amend the Agreement as follows:

1. Article 1, Section 1.1 Sewer Line Construction by Palomar. Add the following:

In addition to the construction of the water and sewer improvements identified in the plans prepared by Masson & Associates, Palomar shall abandon the manholes located along its westerly boundary. Said manholes shall be abandoned by removal, at a minimum, of the frames and covers (to be salvaged to District) and the top (cone) section of each manhole, then plug the sewer in each manhole with concrete slurry to a depth of 12" minimum above the top of pipe and fill the remainder to surface with clean, compacted fill material.

2. Article 1, Section 1.2 Costs of Improvements. Add the following:

Because the addition of two extra manholes to the project may/will benefit both Parties in the future for items such as sewage flow monitoring/measurement, waste stream sampling/monitoring, regulatory compliance, and determining flow based charges and fees, District will consider reimbursement to Palomar of up to 50% of the construction costs of the two manholes.

Palomar shall be responsible for the costs of abandoning the manholes located within a District easement along the Interstate 15/Palomar boundary. Upon abandonment, District shall Quit Claim the existing easement(s) to Palomar.

Article 1, Section 1.3 Construction Timeline. Replace the subsections as follows:

(c) Palomar agrees to complete construction no later than eight (8) weeks after completion of the Sewer Lift Station improvements stated in the Passerelle and D.R. Horton Agreement (the “D.R. Horton Completion Date”). In no instance shall Palomar be allowed to discharge sewage into the new Sewer Line after September 1, 2018.

(d) The Parties agree that should Palomar fail to complete construction within eight (8) weeks of the Sewer Lift Station Completion Date, or fail to complete construction before September 1, 2018, the District shall have the right to commence and/or prosecute to completion construction of the sewer line on Palomar’s property, meeting District’s reasonable requirements (consistent with any agreement reached pursuant to paragraph 1.1, if any) with all costs to be borne by Palomar, and to be paid by Palomar within thirty (30) days of receipt of the District’s invoice for all such costs.

3. Article 1, Section 1.5 Easement. Replace the section with the following:

Palomar has granted District a forty-five (45) foot wide easement per Document Number 2018-0010737, of Official Records, dated January 10, 2018. Palomar shall also grant an easement for access to the sewer manhole connecting the Pala Mesa sewer main to the Palomar sewer main, located near the westerly property line at Interstate 15. The District shall have authority to record the Easement Deeds, and the District’s authority shall not be subject to conditions. The District shall not be required to perform any obligation set forth herein, or to provide any sewer or other service to the Palomar College Site, unless and until the Easement Deeds are recorded.

IN WITNESS WHEREOF, the Parties, for themselves, do hereby agree to the full performance of the covenants herein and have caused this Amendment to be executed on the date first set forth above.

RAINBOW MUNICIPAL WATER DISTRICT

PALOMAR COMMUNITY COLLEGE DISTRICT

By: \_\_\_\_\_

By: \_\_\_\_\_

Name: Tom Kennedy

Name: \_\_\_\_\_

Title: General Manager

Title: \_\_\_\_\_

APPROVED AS TO FORM

APPROVED AS TO FORM

By: \_\_\_\_\_

By: \_\_\_\_\_

Name: Alfred E. Smith, II

Name: \_\_\_\_\_

Title: District’s General Counsel

Title: \_\_\_\_\_



---

**BOARD OF DIRECTORS**

5/22/2018

---

**SUBJECT**

DISCUSSION AND POSSIBLE ACTION ON REQUEST TO QUITCLAIM EASEMENTS FOR PALA MESA HIGHLANDS DEVELOPMENT TM 5187-1

**BACKGROUND**

The Pala Mesa Highlands development is a 124 lot subdivision located on Old Highway 395 south of Pala Mesa Drive. The District owns 20 foot wide easements which run through the Western parcels of the development for a 12" steel waterline which has been relocated into the street according to the improvement plans.

**DESCRIPTION**

Beazer Homes has completed the relocation of the waterline which formerly occupied the easements in question. The District no longer needs easement rights in this location to access and maintain the pipeline. Therefore, the easements can be quitclaimed. Quitclaiming the easements will relinquish rights back to the property owners. Beazer Homes has granted a replacement easement (Document 2015-0560078) for the remaining portion of the offsite waterline which is not in the road.

**POLICY/STRATEGIC PLAN KEY FOCUS AREA**

Strategic Focus Area Two: Asset Management. Replacing a 53 year old pipe and relocating it within the road of the new subdivision reduces the required maintenance effort for the pipe.

**BOARD OPTIONS/FISCAL IMPACTS**

No fiscal impacts to the District. Developer to pay for all costs of the Development.

- 1) Authorize the General Manager to execute the quitclaim deeds associated with the easements for the abandoned waterline.
- 2) Provide other direction to staff.

**STAFF RECOMMENDATION**

Staff recommends Option 1.



Michael Powers, P.E.  
Associate Engineer

May 22, 2018



**RECORDING REQUESTED BY:**

Rainbow Municipal Water District

**WHEN RECORDED RETURN TO:**

Rainbow Municipal Water District  
3707 Old Highway 395  
Fallbrook, California 92028

**EASEMENT QUITCLAIM DEED**

DEED TRANSFER TAX: \$ NONE NO CONSIDERATION  
EXEMPT UNDER SEC. 11922 REVENUE TAXATION CODE

Assessor's Parcel No.: **125-050-72**  
**125-051-03-10,26**  
**125-052-20-22**  
**125-053-24,33-35,57**

For valuable consideration Rainbow Municipal Water District, A Municipal Corporation, organized under the Municipal Water District Act of 1911 as amended, as Grantor, hereby remise, release and forever quitclaim to Beazer Homes Holdings, LLC, a Delaware limited liability company, successor by conversion to Beazer Homes Holdings Corp., a Delaware corporation, the following described real property:

The portion of that certain Grant of Right of Way recorded February 10, 1965 as File/Page No. 24052, of Official Records, in the County of San Diego, State of California, within County of San Diego Tract No. 5187-1, Map No. 16124, as depicted in **Exhibit "A"**, Sheet 21 of said Tract/Map, attached hereto and made a part hereof.

Rainbow Municipal Water District

Date: \_\_\_\_\_

By: \_\_\_\_\_  
District General Manager

A notary public or other officer completing this certificate verifies only the identity of the individual who signed the document to which this certificate is attached, and not the truthfulness, accuracy, or validity of that document.

State of California )  
County of San Diego )  
 )

On \_\_\_\_\_, before me, \_\_\_\_\_, Notary Public personally appeared \_\_\_\_\_ who proved to me on the basis of satisfactory evidence to be the person(s) whose name(s) is/are subscribed to the within instrument and acknowledged to me that he/she/they executed the same in his/her/their authorized capacity(ies), and that by his/her/their signature(s) on the instrument the person(s) or the entity upon behalf of which the person(s) acted, executed this instrument.

I certify under PENALTY OF PERJURY under the laws of the State of California that the foregoing paragraph is true and correct.

WITNESS my hand and official seal.

Signature \_\_\_\_\_  
Signature of Notary Public

MAP NO. 16124

COUNTY OF SAN DIEGO TRACT NO. 5187-1

SHEET 21 OF 22 SHEETS

① CENTERLINE OF AN EASEMENT, 20.00 FEET WIDE, GRANTED TO RANDOM MARSHALL UNDER DISTRICT FOR OCC 222, FEB. 10, 1983, P/P 24032 AND JAN. 10, 1984, P/P 4353, BOTH O.R. (TO BE CANCELLED FOLLOWING THE ACCEPTANCE OF THE NEW IMPROVEMENTS)

LINE TABLE		
NO.	BEARING	DISTANCE
L1	S40°32'17"E	40.79'
L2	S2°02'33"W	48.83'
L3	S3°21'49"E	58.11'
L4	S4°25'49"E	170.84'
L5	N12°04'04"W	91.30'

LINE TABLE		
NO.	BEARING	DISTANCE
L6	N10°04'04"W	82.00'
L7	N54°30'43"W	130.00'
L8	N35°30'17"E	83.30 L3'
L9	N6°20'17"E	719.27'

CURVE TABLE			
NO.	DELTA	RADIUS	LENGTH
C1	12°33'12"	800.00'	175.20'
C2	8°12'15"	600.00'	96.20'
C3	25°22'00"	400.00'	177.00'
C4	28°05'00"	700.00'	307.83'

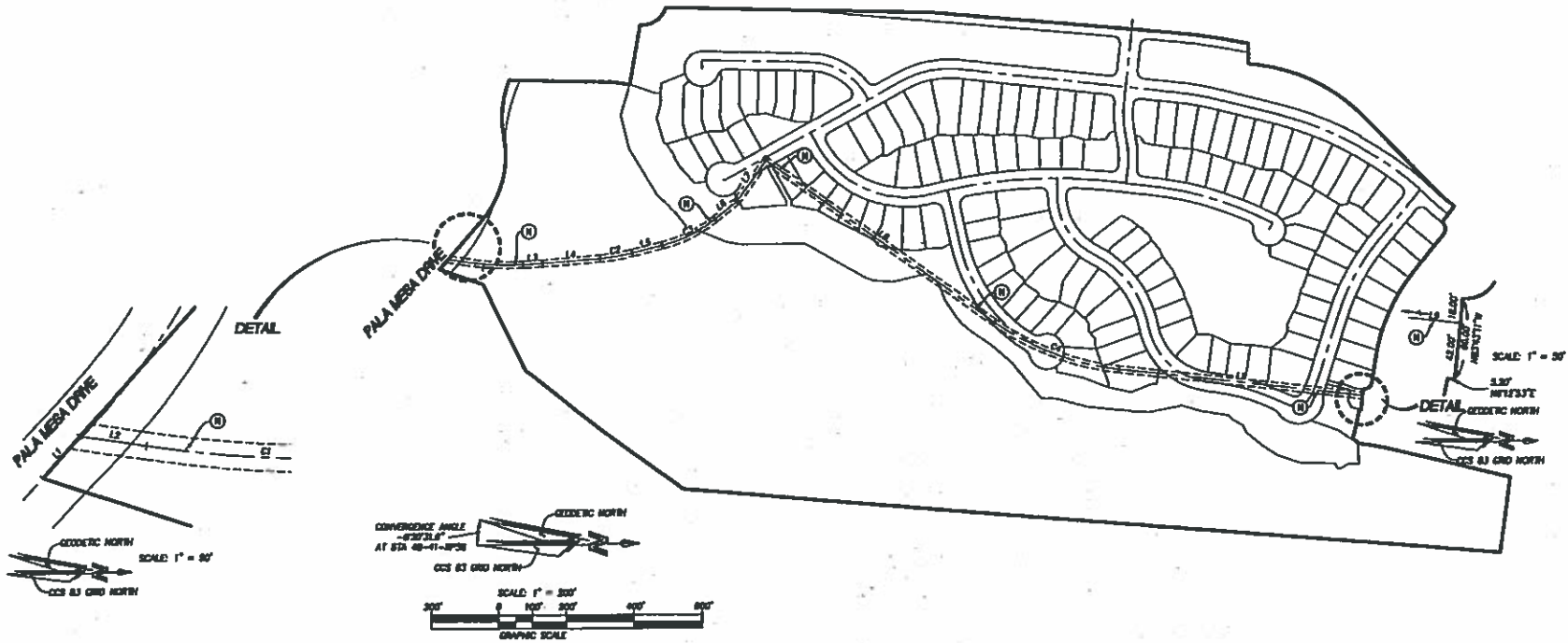

Page 115 of 194

EXHIBIT "A"



**RECORDING REQUESTED BY:**

Rainbow Municipal Water District

**WHEN RECORDED RETURN TO:**

Rainbow Municipal Water District  
3707 Old Highway 395  
Fallbrook, California 92028

**EASEMENT QUITCLAIM DEED**

DEED TRANSFER TAX. \$ NONE NO CONSIDERATION  
EXEMPT UNDER SEC. 11922 REVENUE TAXATION CODE

Assessor's Parcel No.: **125-050-72**  
**125-051-03-10,26**  
**125-052-20-22**  
**125-053-24,33-35,57**

For valuable consideration Rainbow Municipal Water District, A Municipal Corporation, organized under the Municipal Water District Act of 1911 as amended, as Grantor, hereby remise, release and forever quitclaim to Beazer Homes Holdings, LLC, a Delaware limited liability company, successor by conversion to Beazer Homes Holdings Corp., a Delaware corporation, the following described real property:

The portion of that certain Grant of Right of Way recorded January 10, 1966 as File/Page No. 4213, of Official Records, in the County of San Diego, State of California, within County of San Diego Tract No. 5187-1, Map No. 16124, as depicted in Exhibit "A", Sheet 21 of said Tract/Map, attached hereto and made a part hereof.

Rainbow Municipal Water District

Date: \_\_\_\_\_

By: \_\_\_\_\_  
District General Manager

A notary public or other officer completing this certificate verifies only the identity of the individual who signed the document to which this certificate is attached, and not the truthfulness, accuracy, or validity of that document.

State of California )  
County of San Diego )  
 )

On \_\_\_\_\_, before me, \_\_\_\_\_, Notary Public

personally appeared \_\_\_\_\_ who proved to me on the basis of satisfactory evidence to be the person(s) whose name(s) is/are subscribed to the within instrument and acknowledged to me that he/she/they executed the same in his/her/their authorized capacity(ies), and that by his/her/their signature(s) on the instrument the person(s) or the entity upon behalf of which the person(s) acted, executed this instrument.

I certify under PENALTY OF PERJURY under the laws of the State of California that the foregoing paragraph is true and correct.

WITNESS my hand and official seal.

Signature \_\_\_\_\_  
Signature of Notary Public

① CENTERLINE OF AN EASEMENT, 20.00 FEET WIDE GRANTED TO SANDROW MUNICIPAL WATER DISTRICT, PER DOC REC. FEB. 10, 1963, P/P 24022 AND JAN. 10, 1965, P/P 4213, BOTH O.A. (TO BE OUTLINED FOLLOWING THE ACCEPTANCE OF THE NEW IMPROVEMENTS)

LINE TABLE		
NO.	BEARING	DISTANCE
L1	S40°26'17"E	40.79'
L2	S50°25'27"W	48.83'
L3	S33°46'2"E	28.11'
L4	S43°46'2"E	170.84'
L5	N13°46'14"W	61.30'

LINE TABLE		
NO.	BEARING	DISTANCE
L6	N38°16'04"W	82.00'
L7	N54°26'43"W	150.00'
L8	N39°20'17"E	830.13'
L9	N42°01'7"E	718.27'

CURVE TABLE			
NO.	DELTA	RADIUS	LENGTH
C1	15°23'14"	800.00'	178.25'
C2	8°12'5"	800.00'	261.30'
C3	25°32'00"	400.00'	177.00'
C4	28°05'20"	784.00'	387.83'

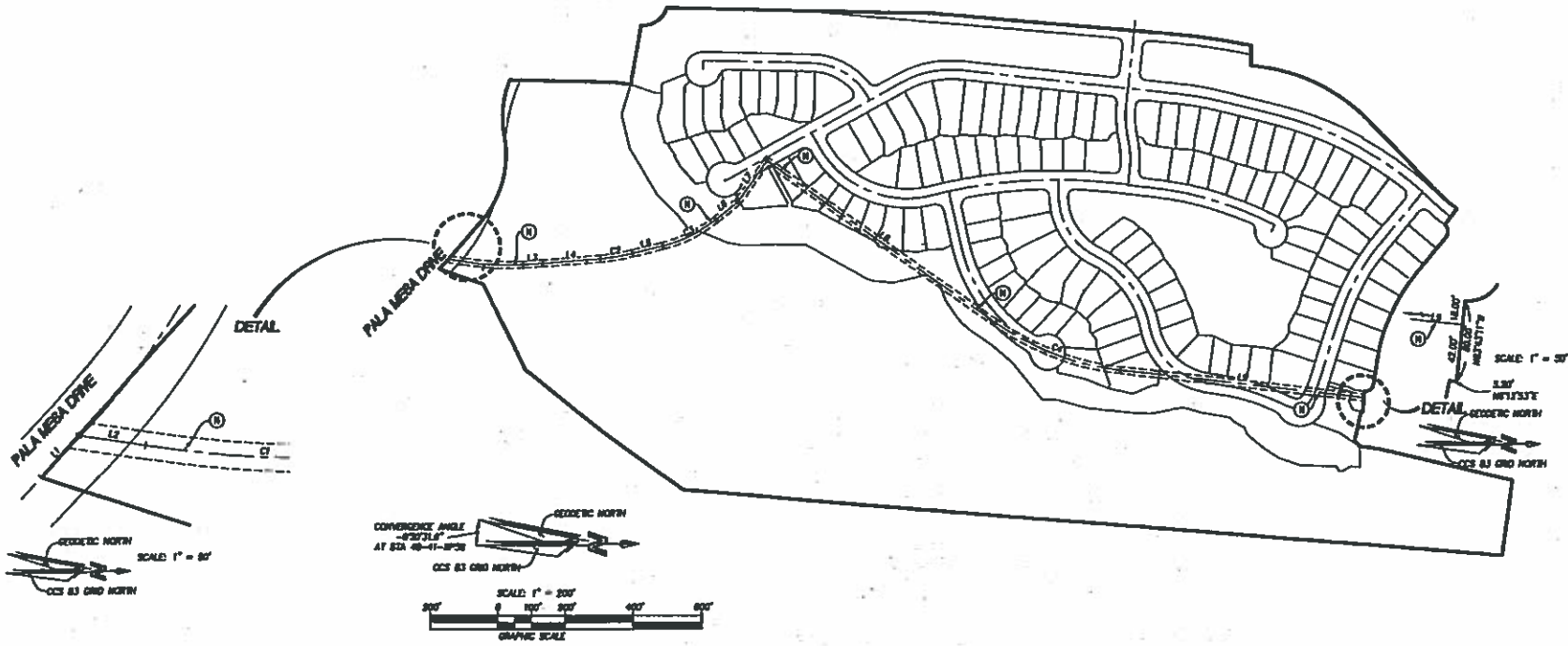

**RECORDING REQUESTED BY:**

Rainbow Municipal Water District

**WHEN RECORDED RETURN TO:**

Rainbow Municipal Water District  
3707 Old Highway 395  
Fallbrook, California 92028

NO FEE REQUIRED PER  
GOVERNMENT CODE SECTION 6103

**DOC# 2015-0560078**



Oct 27, 2015 10:12 AM

OFFICIAL RECORDS  
Ernest J. Dronenburg, Jr.,  
SAN DIEGO COUNTY RECORDER  
FEES: \$0.00

PAGES: 10

**GRANT OF RIGHT OF WAY**

DEED TRANSFER TAX: \$ 0  
EXEMPT UNDER SEC. 11922 OF  
REVENUE TAXATION CODE

Parcel No. **125-050-70 & 71**

For valuable consideration **BEAZER HOMES HOLDINGS CORP., a Delaware corporation** as Grantor, hereby grants to Rainbow Municipal Water District, A Municipal Corporation, organized under the Municipal Water District Act of 1911 as amended, as Grantee, its successors and assigns, an easement and right of way **20.00** feet in width in, upon, over, under, and across the lands hereinafter described, to erect, install, construct, reconstruct, replace, repair, alter, operate, maintain, inspect and use a pipeline or pipelines for any and all purposes, together with any easement roads and appurtenances within the right-of-way including but not limited to conduits and cables for communication purposes, at such location and elevations, upon, along, over and under the hereinafter described right-of-way as Grantee may now or hereafter deem convenient and necessary from time to time, together with right of ingress thereto and egress therefrom to and along said right-of-way by a practical route or routes, in, upon, over, and across the hereinafter described lands, together with the right to clear and keep clear said right-of-way from buildings and structures.

The lands in which said easement of right-of-way is hereby granted are situated in the County of San Diego, State of California, and are particularly described as follows, to wit:

**See Exhibit "A" and "B"**

Grantor hereby also grants to grantee the temporary use of such adjacent land of Grantor as is necessary to install the facilities provided for under the terms of the easement granted herein.

It is further understood and agreed that no other easement or easements shall be granted on, under, over said strip of land by the Grantor to any person, firm or corporation without the previous written consent of said grantee.

Grantor and **their** successors and assigns shall not erect or construct, or permit to be erected or constructed, any building, fences, walls, or other structures of any kind and no trees shall be installed, constructed, erected, placed, planted or maintained in any portion of the easement and right-of-way, and no shrubs or other, plants or vegetation shall be placed, planted or maintained in the portion of the easement and right-of-way which is included within any road, and that no changes in the alignment or grading of any such road will be made without prior written consent of Grantee. It is further understood and agreed the grantor shall not drill any well or wells within the limits of said right-of-way.

Grantee shall have the right to construct and utilize an access road within said easement and shall have the right to erect, maintain and use gates in all of Grantor's fences which now cross or shall hereafter

cross said route or routes, and to trim and cut and clear away any trees and brush whenever in its judgment the same shall be necessary for the convenient and safe exercise of the rights hereby granted, the right to transfer and assign this easement in whole or in part being hereby granted to the Grantee.

It is also understood and agreed by the parties hereto that the Grantor and successors or assigns, shall not increase or decrease, or permit to be increased or decreased the existing ground elevations of the above described right-of-way, existing at the time this document is executed, without the previous written consent of the Grantee.

IN WITNESS WHEREOF, the Grantor(s) executed this instrument this 6 day of August, 2015.

GRANTOR:  
Robert T. Shiota  
(Print Name)

[Signature]  
(Sign Name)

A notary public or other officer completing this certificate verifies only the identity of the individual who signed the document to which this certificate is attached, and not the truthfulness, accuracy, or validity of that document.

State of California )

County of Orange )

On August 7 2015, before me, Diana C Shellman, Notary Public

personally appeared Robert T Shiota who proved to me on the basis of satisfactory evidence to be the person(s) whose name(s) is/are subscribed to the within instrument and acknowledged to me that he/she/they executed the same in his/her/their authorized capacity(ies), and that by his/her/their signature(s) on the instrument the person(s) or the entity upon behalf of which the person(s) acted, executed this instrument.

I certify under PENALTY OF PERJURY under the laws of the State of California that the foregoing paragraph is true and correct.

WITNESS my hand and official seal.

Signature [Signature]  
Signature of Notary Public



**CERTIFICATE OF ACCEPTANCE**

This is to certify that the interest in real property conveyed by the Grant of Right of Way dated August 6, 2015 from Beazer Homes Holdings Corp. to the Rainbow Municipal Water District, organized under the Municipal Water District Act of 1911, is hereby accepted by order of Board of Director's Resolution No.02-13, dated July 3, 2002, authorizing the General Manager to accept and record Grants of Right of Way on behalf of said District.

**RAINBOW MUNICIPAL WATER DISTRICT**

Dated 8/20/15

By [Signature]  
General Manager

Project Pala Mesa Highlands TM 5187-1  
Water Atlas Page No. I-6 Checked by: [Signature] Date: 8/19/15

**EXHIBIT "A"**  
**WATERLINE EASEMENT**  
**LEGAL DESCRIPTION**

PAGE 1 OF 3  
APN 125-050-70 & 71

THE LAND DESCRIBED HEREIN IS LOCATED IN AN UNINCORPORATED AREA OF THE COUNTY OF SAN DIEGO, STATE OF CALIFORNIA, BEING A PORTION OF TRACT "A" OF MONSERATE RANCHO, ACCORDING TO MAP THEREOF ON FILE IN THE OFFICE OF THE SAN DIEGO COUNTY RECORDER IN BOOK 1, PAGE 108 OF PATENTS, BEING PORTIONS OF PARCELS "A" AND "B" PER THAT CERTAIN CERTIFICATE OF COMPLIANCE RECORDED SEPTEMBER 27, 2007, AS DOCUMENT NO. 2007-0630501, OF OFFICIAL RECORDS, MORE PARTICULARLY DESCRIBED AS FOLLOWS:

**PARCEL A**

BEGINNING AT THE EASTERLY CORNER OF LOT 9 OF THE COUNTY OF SAN DIEGO TRACT NO. 4729-1, ACCORDING TO MAP THEREOF NO. 14748, FILED MARCH 1, 2004, IN THE OFFICE OF THE SAN DIEGO COUNTY RECORDER, SAID POINT BEING ON THE SOUTHERLY RIGHT-OF WAY OF PALA MESA DRIVE, (60.00 FEET WIDE), AS SHOWN ON SAID MAP AND THE SOUTHERLY LINE OF THAT CERTAIN RIGHT-OF-WAY GRANTED TO RAINBOW MUNICIPAL WATER DISTRICT AS PARCEL A, PER DOCUMENT RECORDED SEPTEMBER 9, 1985, AS DOCUMENT NO. 85-329180, OF OFFICIAL RECORDS; THENCE ALONG SAID SOUTHERLY LINE THROUGH THE FOLLOWING COURSES: SOUTH 46°47'47" EAST 32.92 FEET (SOUTH 46°48'20" EAST 32.98 FEET PER SAID DOCUMENT) TO THE BEGINNING OF A TANGENT CURVE TO THE LEFT HAVING A RADIUS OF 530.00 FEET AND ALONG SAID CURVE 3.24 FEET THROUGH A CENTRAL ANGLE OF 00°21'00" TO A POINT FROM WHICH A RADIAL LINE BEARS NORTH 42°51'13" EAST, SAID POINT ALSO BEING THE TRUE POINT OF BEGINNING; THENCE CONTINUING ALONG SAID SOUTHERLY LINE AND THE ARC OF SAID CURVE, 23.73 FEET THROUGH A CENTRAL ANGLE OF 02°33'55" TO A POINT OF NON-TANGENCY, A RADIAL LINE TO SAID POINT BEARS SOUTH 40°17'18" WEST; THENCE LEAVING SAID SOUTHERLY LINE, SOUTH 09°01'23" WEST 5.11 FEET, TO THE BEGINNING OF A TANGENT CURVE TO THE LEFT HAVING A RADIUS OF 790.00 FEET; THENCE ALONG SAID CURVE 173.09 FEET THROUGH A CENTRAL ANGLE OF 12°33'12"; THENCE SOUTH 03°31'49" EAST 58.02 FEET; THENCE SOUTH 04°35'49" EAST 170.45 FEET TO THE BEGINNING OF A TANGENT CURVE TO THE LEFT HAVING A RADIUS OF 590.00 FEET; THENCE ALONG SAID CURVE 94.78

**EXHIBIT "A"**  
**WATERLINE EASEMENT**  
**LEGAL DESCRIPTION**

PAGE 2 OF 3  
APN 125-050-70 & 71

FEET THROUGH A CENTRAL ANGLE OF 09°12'15"; THENCE SOUTH 13°48'04" EAST 91.38 FEET TO THE BEGINNING OF A TANGENT CURVE TO THE LEFT HAVING A RADIUS OF 390.00 FEET; THENCE ALONG SAID CURVE 115.44 FEET THROUGH A CENTRAL ANGLE OF 16°57'35" TO A POINT OF NON-TANGENCY, A RADIAL LINE TO SAID POINT BEARS SOUTH 59°14'21" WEST; THENCE SOUTH 52°31'38" EAST 52.56 FEET; THENCE SOUTH 74°17'09" EAST 61.26 FEET TO A POINT ON A NON-TANGENT CURVE TO THE LEFT (PROPOSED PUBLIC RIGHT-OF-WAY VIA DE TODOS SANTOS) WITH A RADIUS OF 52.00 FEET, A RADIAL LINE FROM SAID POINT BEARS SOUTH 55°47'08" EAST; THENCE ALONG SAID PROPOSED RIGHT-OF-WAY AND THE ARC OF SAID CURVE 32.53 FEET THROUGH A CENTRAL ANGLE OF 35°50'32" TO A POINT OF NON-TANGENCY, A RADIAL LINE TO SAID POINT BEARS SOUTH 88°22'19" WEST; THENCE LEAVING SAID PROPOSED RIGHT-OF-WAY, NORTH 74°17'09" WEST 12.03 FEET; THENCE NORTH 15°42'51" EAST 12.00 FEET; THENCE NORTH 74°17'09" WEST 52.75 FEET; THENCE NORTH 52°31'38" WEST 60.20 FEET, TO THE BEGINNING OF A NON-TANGENT CURVE TO THE RIGHT WITH A RADIUS OF 410.00 FEET, A RADIAL LINE FROM SAID POINT BEARS NORTH 58°41'43" EAST; THENCE ALONG SAID CURVE 125.25 FEET THROUGH A CENTRAL ANGLE OF 17°30'13"; THENCE TANGENT TO SAID CURVE, NORTH 13°48'04" WEST 91.38 FEET TO THE BEGINNING OF A TANGENT CURVE TO THE RIGHT HAVING A RADIUS OF 610.00 FEET; THENCE ALONG SAID CURVE 97.99 FEET THROUGH A CENTRAL ANGLE OF 09°12'15"; THENCE NORTH 04°35'49" WEST 170.63 FEET; THENCE NORTH 03°31'49" WEST 58.20 FEET TO THE BEGINNING OF A TANGENT CURVE TO THE RIGHT HAVING A RADIUS OF 810.00 FEET' THENCE ALONG SAID CURVE 177.47 FEET THROUGH A CENTRAL ANGLE OF 12°33'12"; THENCE NORTH 09°01'23" EAST 17.87 FEET TO THE TRUE POINT OF BEGINNING.

CONTAINS: 16,949 SQUARE FEET OR 0.3891 ACRES OF LAND, MORE OR LESS.

**PARCEL B**

BEGINNING AT A POINT ON THE CENTERLINE OF OLD HIGHWAY 395, SHOWN AS STATION 2297+03.07 B.C. "FL-A" LINE PER THE STATE DEPARTMENT OF TRANSPORTATION MONUMENTATION MAP, FILED AS MISCELLANEOUS SURVEY

**EXHIBIT "A"**  
**WATERLINE EASEMENT**  
**LEGAL DESCRIPTION**

PAGE 3 OF 3  
APN 125-050-70 & 71

865 WITH THE SAN DIEGO COUNTY SURVEYOR, THENCE ALONG SAID CENTERLINE, SOUTH 05°00'20" WEST 1002.90 FEET (SOUTH 05°00'00" WEST PER MS 865) TO THE INTERSECTION WITH THE CENTERLINE OF MOHEGAN LANE (PROPOSED PUBLIC RIGHT-OF-WAY); THENCE ALONG SAID CENTERLINE, NORTH 83°38'15" WEST 120.03 FEET; THENCE LEAVING SAID CENTERLINE, NORTH 06°21'45"EAST 30.00 FEET TO NORTHERLY RIGHT-OF-WAY OF SAID MOHEGAN LANE AND THE TRUE POINT OF BEGINNING; THENCE ALONG SAID NORTHERLY RIGHT-OF-WAY, NORTH 83°38'15" WEST 35.06 FEET TO THE BEGINNING OF A TANGENT CURVE TO THE RIGHT HAVING A RADIUS OF 20.00 FEET; THENCE ALONG SAID CURVE 4.99 FEET THROUGH A CENTRAL ANGLE OF 14°17'12" TO A POINT OF NON-TANGENCY, A RADIAL LINE TO SAID POINT BEARS SOUTH 20°38'57" WEST; THENCE LEAVING SAID NORTHERLY RIGHT-OF-WAY, NORTH 06°21'45" EAST 12.58 FEET; THENCE SOUTH 83°38'15" EAST 40.00 FEET; THENCE SOUTH 06°21'45" WEST 13.20 FEET TO SAID NORTHERLY RIGHT-OF-WAY AND THE TRUE POINT OF BEGINNING.

CONTAINS 527 SQUARE FEET OR 0.0121 ACRES OF LAND, MORE OR LESS.

ALL SUBJECT TO ALL COVENANTS, EASEMENTS AND AGREEMENTS OF RECORD.

ALL AS SHOWN ON EXHIBIT "B", ATTACHED HERETO AND BY THIS REFERENCE MADE A PART HEREOF.

DATED THIS 24<sup>th</sup> DAY OF July, 2015.

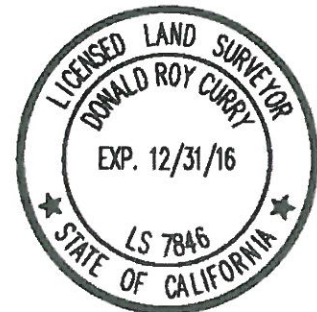

Donald Roy Curry  
DONALD ROY CURRY, L.S. 7846  
EXP. 12/31/16

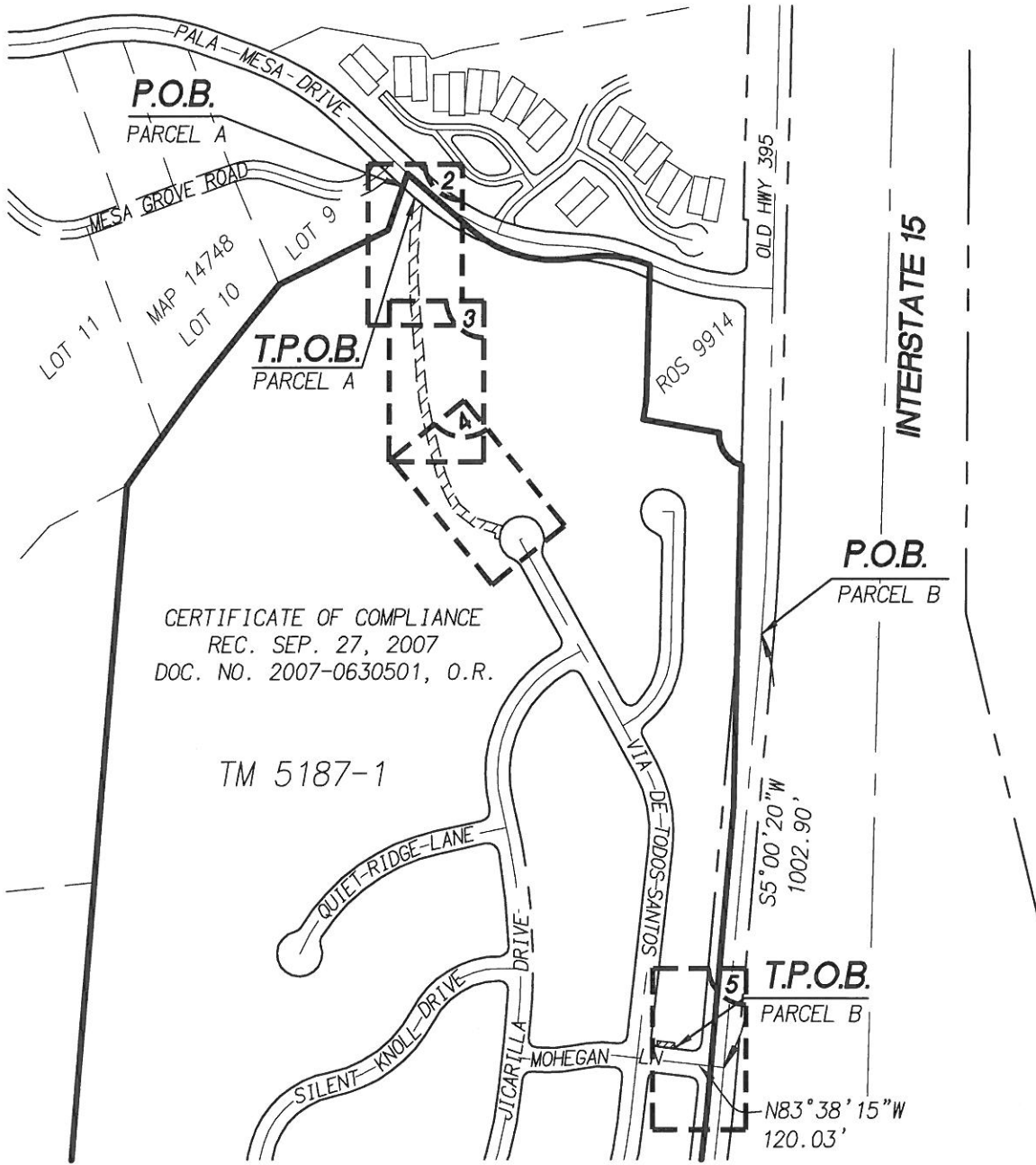



CERTIFICATE OF COMPLIANCE  
 REC. SEP. 27, 2007  
 DOC. NO. 2007-0630501, O.R.

TM 5187-1

S5°00'20"W  
 1002.90'

N83°38'15"W  
 120.03'

**LEGEND**

-  INDICATES MAP BOUNDARY
-  INDICATES PROPOSED STREET CENTERLINE
-  INDICATES RMWD EASEMENT

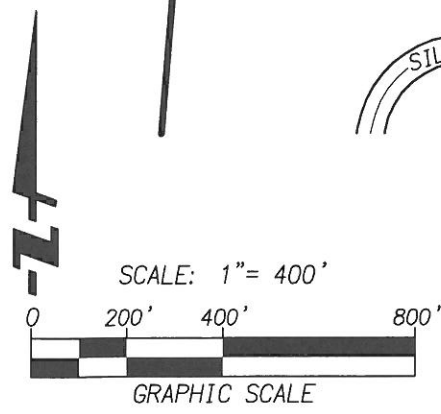

**RAINBOW MUNICIPAL WATER DISTRICT**

Date: 07-24-15  
 Scale: 1" = 400'  
 A.P.N. 125-050-70 & 71

**GRANT OF WATER EASEMENT**  
**BEAZER HOMES**  
 Page 123 of 194

Drawn By: FUSCOE ENG.  
 Doc. No.  
 RMWD Chk:



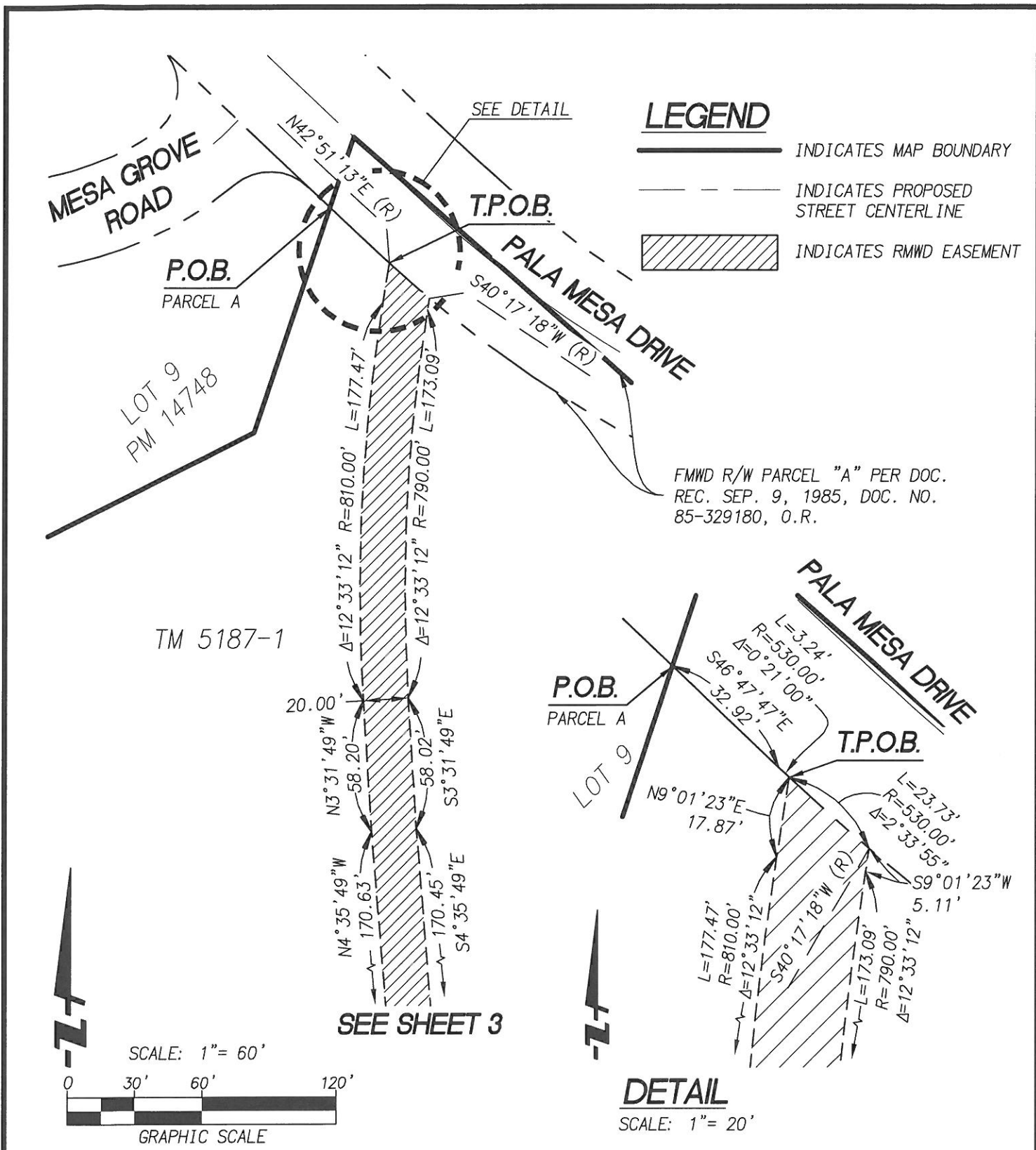

**RAINBOW MUNICIPAL WATER DISTRICT**

Date: 07-24-15	<b>GRANT OF WATER EASEMENT</b> <b>BEAZER HOMES</b> Page 124 of 194	Drawn By: FUSCOE ENG.
Scale: 1" = 60'		Doc. No.
A.P.N. 125-050-70 & 71		RMWD Chk:

M:\PROJECTS\02778 BEAZER HOMES SOUTHERN CA\001-02 PALA MESA HIGHLANDS\MAP\CAD\LEGAL DESCRIPTIONS\RMWD EASEMENTS\NEW\RMWD EASEMENT\RMWD PAGE 2.DWG (07-24-15 4:12:06PM)

SEE SHEET 2

LEGEND



INDICATES RMWD EASEMENT

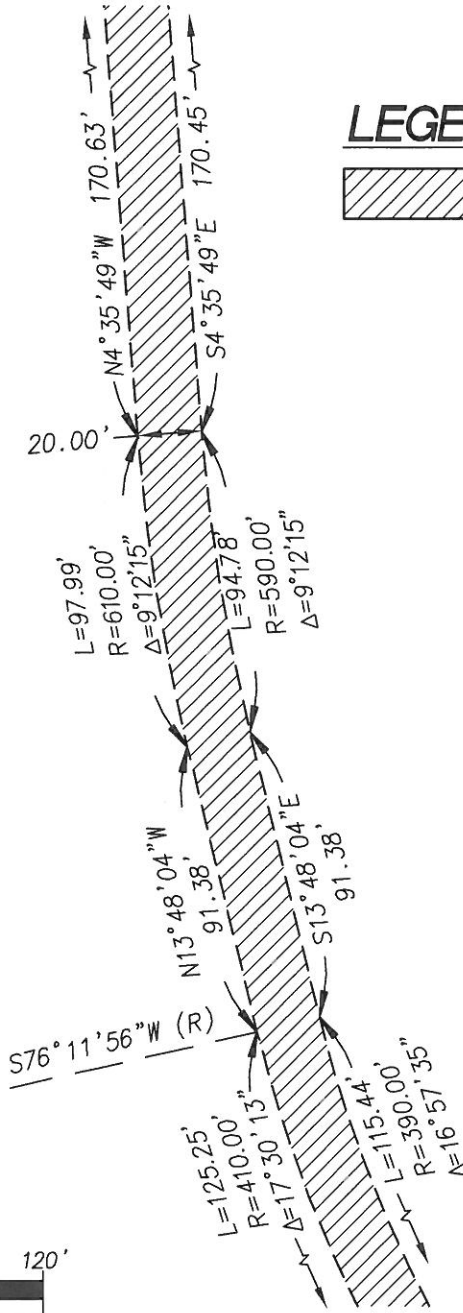

TM 5187-1

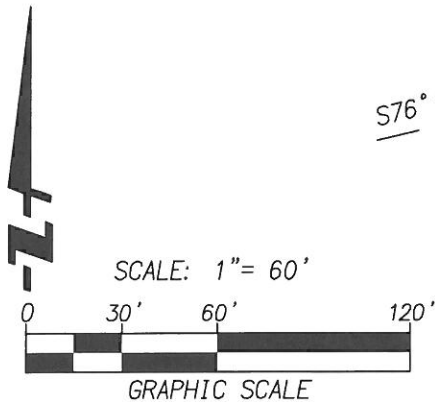

SEE SHEET 4

RAINBOW MUNICIPAL WATER DISTRICT

Date: 07-24-15

Scale: 1" = 60'

A.P.N. 125-050-70 & 71

GRANT OF WATER EASEMENT

BEAZER HOMES  
Page 125 of 194





Drawn By: FUSCOE ENG.

Doc. No.

RMWD Chk:

SEE SHEET 3

**LEGEND**

-  INDICATES MAP BOUNDARY
-  INDICATES PROPOSED STREET CENTERLINE
-  INDICATES FUTURE R/W
-  INDICATES RMWD EASEMENT

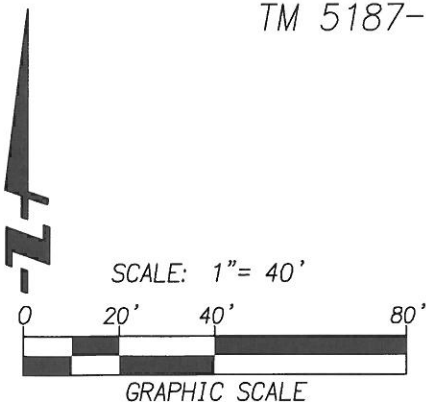
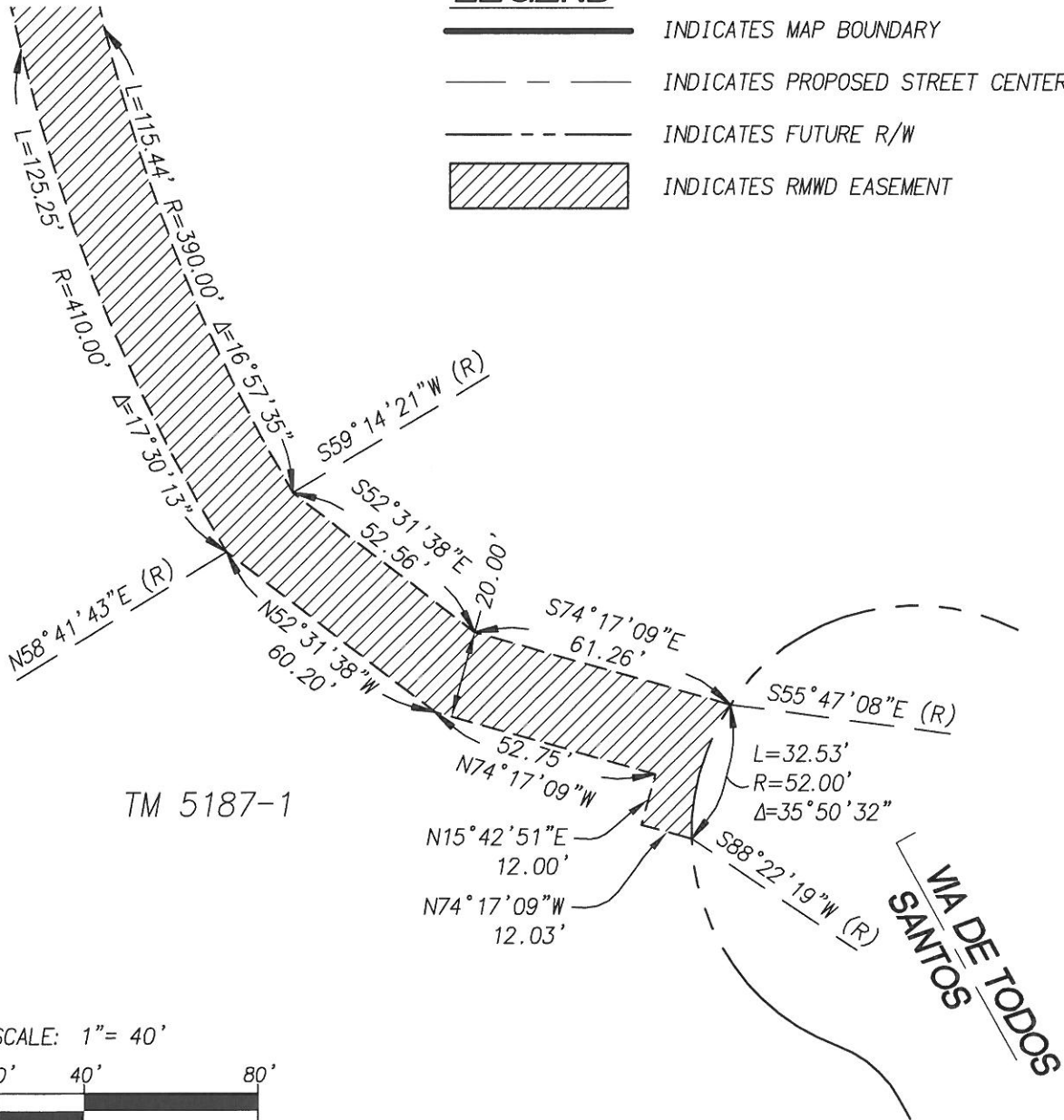

**RAINBOW MUNICIPAL WATER DISTRICT**



**GRANT OF WATER EASEMENT**

**BEAZER HOMES**  
Page 126 of 194

Date: 07-24-15  
Scale: 1" = 40'  
A.P.N. 125-050-70 & 71

Drawn By: FUSCOE ENG.  
Doc. No.  
RMWD Chk:

**LEGEND**

-  INDICATES MAP BOUNDARY
-  INDICATES STREET CENTERLINE
-  INDICATES RMWD EASEMENT

CURVE TABLE			
NO.	DELTA	RADIUS	LENGTH
C1	14° 17' 12"	20.00'	4.99'

LINE TABLE		
NO.	BEARING	DISTANCE
L1	N83° 38' 15"W	35.06'
L2	N6° 21' 45"E	12.58'
L3	S83° 38' 15"E	40.00'
L4	S6° 21' 45"W	13.20'

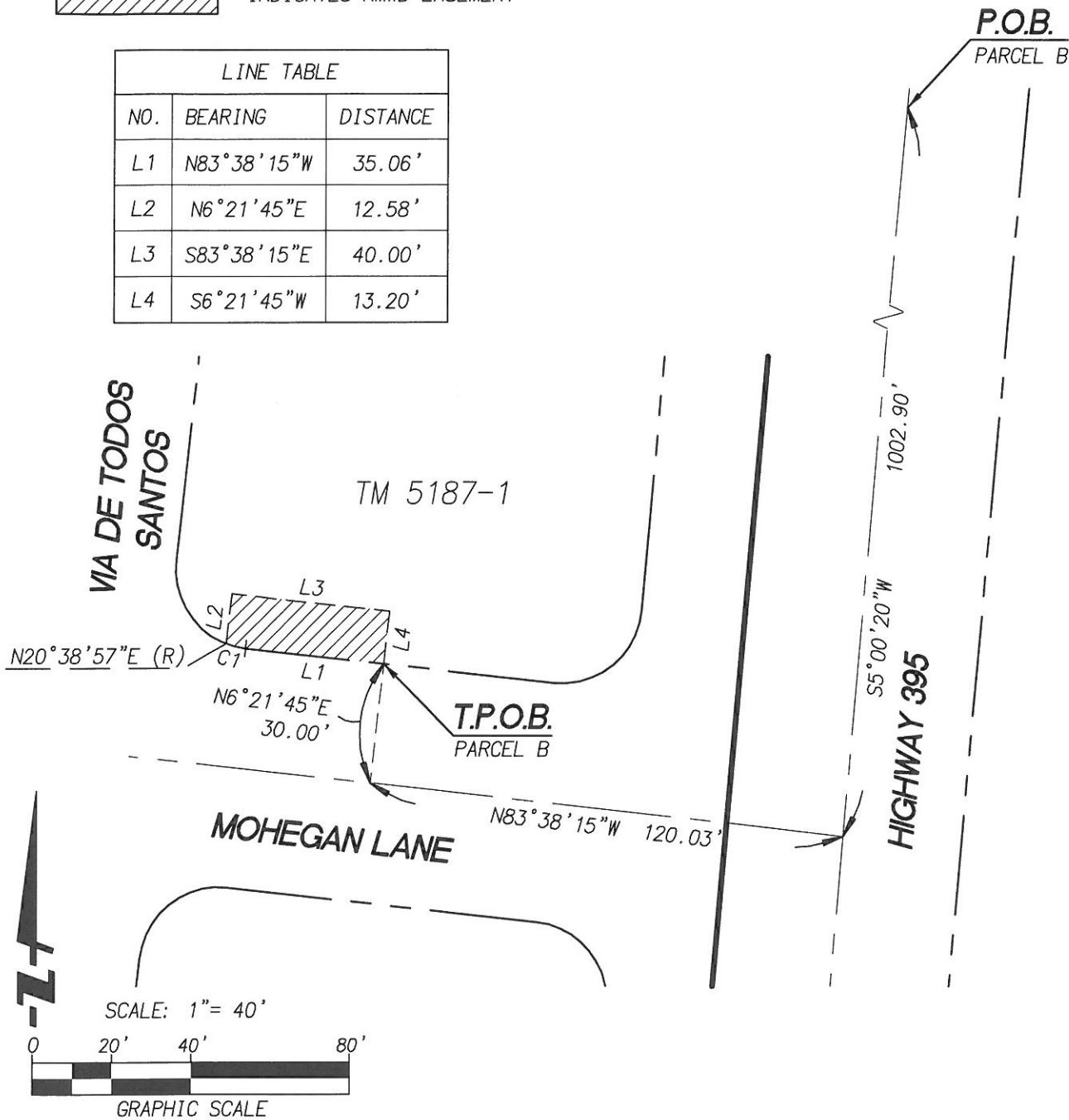

**RAINBOW MUNICIPAL WATER DISTRICT**

Date: 07-24-15

SCALE: 1" = 40'

A.P.N. 125-050-70 & 71

**GRANT OF WATER EASEMENT**

**BEAZER HOMES**  
Page 127 of 194

Drawn By: FUSCOE ENG.

Doc. No.

RMWD Chk:

---

**BOARD OF DIRECTORS**

May 22, 2018

---

**SUBJECT**

DISCUSSION AND POSSIBLE ACTION TO APPROVE A CHANGE ORDER FOR REDESIGN SERVICES FOR THE RAINBOW HEIGHTS PUMP STATION REHABILITATION PROJECT

---

**BACKGROUND**

The Rainbow Heights Pump Station is the largest of the District's seven pump stations. It pumps water from the North Zone to the four-million-gallon Rainbow Heights Tank which supplies water at a hydraulic grade line of 1,967 feet. The Rainbow Heights Zone extends north to the Magee Pump Station, which serves the Magee Zone, and is separated from the Gomez Zone to the east and south by closed valves. The Rainbow Heights Zone is the sole supply to the Magee Zone and serves as an emergency supply for the Gomez, Vallecitos, and North Zones. Demands in the Rainbow Heights Zone are approximately 0.54 MGD and are a mix of domestic and agriculture use.

The Rainbow Heights Pump Station Rehabilitation Project originally included replacement of the two larger natural gas motors due to Air Pollution Control Board permitting, age, and maintenance costs. Other improvements included minor upgrades to the mechanical, electrical, and communications systems.

The Board approved a project design change order in December, 2016, which included removal of the existing concrete building, replacing it with a new metal building to house the four pumps/motors and electrical equipment/control centers, as well as site security lighting and conduit for a future security system.

The total design contract amount to date is \$182,139. The construction cost estimate is \$1,650,000.

**DESCRIPTION**

Metropolitan Water District has an easement/right of way across the easterly half of the pump station property. The two electric motor pumps are located within the MWD easement, requiring their approval of design and improvements. The plans were submitted to them for review in December 2017 and they notified us in January 2018 that the location of the proposed improvements within their easement, including the existing pumps, canopy and fencing was not acceptable.

Staff reviewed the scope of the project and it was determined that the pumping capacity required for the supply within the zones could be met with two pumps and a standby. With some minor piping, the third pump can be located next to the two existing natural gas motors/pumps within a

smaller building. The two existing electric motors/pumps within the easement can be abandoned, with the expectation that those motors will replace the natural gas motors.

The redesign concept was sent to MWD for comment in March 2018 and they responded in writing in April that the location of the building and other proposed improvements were acceptable. Final plans are to be submitted to them for review and approval.

Staff requested a proposal for redesign from Infrastructure Engineering Corporation (IEC), the design engineer. They submitted a proposal dated April 27, 2018 for redesign of the project for a not-to-exceed fee of \$70,827. The total design/redesign budget for the project will increase to \$252,966 with approval of this proposed change order.

The revised construction cost estimate is \$1,530,00, which is a reduction of \$120,000 from the original estimate.

The Engineering Services Committee reviewed this proposal at their May 2, 2018 meeting and recommended approval of the proposed scope change and change order amount

**POLICY/STRATEGIC PLAN KEY FOCUS AREA**

Strategic Focus Area 2: Asset Management. Rehabilitation of existing District facilities is essential to maintaining reliable water supplies to customers. Planning for and implementing replacement of aging infrastructure and mechanical systems is part of the District's Capital Improvement Program.

**BOARD OPTIONS/FISCAL IMPACTS**

- 1) Approve the revised project scope and Change Order #05 to provide redesign services for the Rainbow Heights Pump Station Rehabilitation Project with additional scope fees not to exceed \$70,827.
- 2) Provide other direction to staff.

**STAFF RECOMMENDATION**

Staff recommends Option 1.



Ken Gerdes, PE  
Interim District Engineer

May 22, 2018



## CONTRACT CHANGE ORDER 05

Date: May 22, 2018

Project No. 600-600001  
Contract No. 16-12

**Infrastructure Engineering Corporation**  
14271 Danielson Street  
Poway, CA 92064

Project Title: Rainbow Heights Pump Station Natural Gas Motor Replacements

This Change Order provides for: Additional fees for redesign services necessary due to MWD rejection of original design within MWD Easement. Professional Service Agreement, Contract Number 16-12, dated September 12, 2016, and extended by Change Orders #02, #03 and #04.

Total Cost: \$70,827 (Per attached IEC Proposal dated April 27, 2018)

Schedule: Professional Services Agreement expiration date extended to August 31, 2018.

CONTRACT SUMMARY			
Original Contract Amount	Previous Change Orders	This Change Order	Total Contract Amount
\$107,493	CO# 01: \$61,296		\$168,789
	CO# 02: \$0		\$168,789
	CO# 03: \$7,245		\$176,034
	CO# 04: \$6,105		\$182,139
		CO# 05: \$70,827	\$252,966

Recommended by: \_\_\_\_\_  
Engineering Manager

Date: \_\_\_\_\_

Approved by: \_\_\_\_\_  
General Manager

Date: \_\_\_\_\_

Approved by: \_\_\_\_\_  
Consultant

Date: \_\_\_\_\_

Notice to Proceed: Signature acknowledgment above authorizes Infrastructure Engineering Corporation to continue work as prescribed in this Change Order.





April 27, 2018

Mr. Ken Gerdes, PE  
Interim District Engineer  
Rainbow Municipal Water District  
3707 Old Hwy 395  
Fallbrook, CA 92028

**RE: Proposal for Redesign of the Rainbow Heights Pump Station, Project No. 600-600001,  
Based on agreed upon changes between Metropolitan Water District and RMWD**

Dear Mr. Gerdes:

Infrastructure Engineering Corporation (IEC) is pleased to provide design services for the referenced project. This proposal is based on recommended modifications by Rainbow Municipal Water District (District) and the review of the proposed recommendation by the Metropolitan Water District (MWD) dated April 9, 2018.

**SCOPE OF SERVICES**

We propose to provide a set of bid documents as a change order to IEC's existing Contract No. 16-12, dated September 12, 2016.

The proposed scope of services is included in Attachment A.

**FEE**

The estimated fee and level of effort for the proposed services is summarized in the table in Attachment B. Fees for services performed will be billed on a time and materials basis toward the not-to-exceed limit in accordance with the rate schedule attached.

We sincerely appreciate the opportunity to provide this proposal and assist the District with this project. Please contact me at (760) 214-2300 should you have any questions or need further information regarding this project.

Sincerely,



Richard H. Kennedy, PE  
Senior Project Manager

Cc: Robert Weber, PE

**ATTACHMENT "A"**  
**SCOPE OF SERVICES**  
**RAINBOW HEIGHTS PUMP STATION REHABILITATION**

**Scope of Services**

IEC will provide the following services to modify the existing design of the Rehabilitation Rainbow Heights Pump Station, within a period of 3 months following the notice to proceed, per the tasks below:

**Task 1 Project Management**

The Consultant's project manager shall prepare and submit during the last week of each calendar month as prescribed in the Professional Services Agreement a written report to address the progress of work on each task and to identify any areas of concern regarding project design execution and design delivery schedule. (Duration of the redesign is assumed to be 3 months.)

**Task 2 Basis of Design Report Modifications**

Prepare a one to three-page technical memorandum (TM) explaining the basic changes that have occurred since the original Basis of Design (BODR) Report. The TM shall be designed to be included within the original BODR binder for future reference. Replacement drawings for original BODR will not be produced. After the District reviews the draft TM, make agreed upon changes and submit the final TM.

**Task 3 Revise Bid Documents**

Revise the existing bid drawings as listed below:

- G-1 Title Sheet
- D-1 Existing Site Demolition Plan
- D-2 Existing Pump Station Demolition Plan
- C-1 Proposed Site Layout and Grading Plan
- M-1 Proposed Pump Station Building Plan
- M-2 Proposed Pump Station Sections and Details
- M-3 Proposed Pump Station Building Elevations 1
- M-4 Proposed Pump Station Building Elevations 2
- MD-3 Mechanical Details
- S-4 Foundation Plan
- S-5 Structural Details
- E-1 Standard Electrical Symbols & Abbreviations
- E-2 Electrical Site Plan
- E-3 Single Line Diagram
- E-4 Elevations
- E-5 Pump Station Power and Signal Plan
- E-6 Pump Station Lighting and Receptacle Plan

- E-7 Controls 1
- E-8 Controls 2
- E-9 Electrical Schedules
- E-10 Electrical Details
- E-11 Electrical Demolition Plan
- E-12 RTU Controls
- E13- RTU Layout
- I-1 Standard P&ID Symbols and Abbreviations
- I-2- P&ID 1
- I-3 Pump Station P&ID – 2 Of 2
- I-5 System Architecture

Revise the existing specifications listed below:

Front End

01010 Summary of Work

01039 Coordination and Meetings

01115 Construction Sequence and Coordination (MOFO)

01116 New Vertical Turbine Pumps

15100 Valves

15805 Ventilation Equipment

Division 16/17 Specifications

The drawings and specs will be submitted at 100% complete. After District review make agreed upon changes and submit the final bid documents.

#### **Task 4 SDG&E coordination**

Coordinate the modified electrical design with SDG&E.

#### **Task 5 Cost Opinion**

Prepare an updated Opinion of Probable Construction Cost as part of the BODR TM and at the 100% submittal. A Final Engineer's Estimate corresponding shall be submitted with the final submittal.

**Rainbow Municipal Water District  
Redsign of the Rainbow Heights Pump Station Rehabilitation**

Task/ Subtask	Task/Subtask Description	Principal	Sr. Project Manager	Project Engineer/ Designer	Engineer II/ CAD II Designer	Word Processor/ Admin Support	Subtask Labor-Hours	Subtask Labor Cost	Direct Cost	Kelsey Structural	Morales Pham & Associates	Total Cost
		\$245.00	\$230.00	\$165.00	\$140.00	\$98.00						
<b>TASK 1</b>	<b>Project Management</b>											<b>\$1,674</b>
	Progress Reporting and Invoicing		6			3	9	\$1,674	\$0		\$0	\$1,674
<b>TASK 2</b>	<b>PDR Revision</b>										\$3,000	<b>\$5,764</b>
	General and Mechanical		4	8		2	14	\$2,436	\$0		\$0	\$2,436
	Electrical		1			1	2	\$328	\$0		\$3,000	\$3,328
<b>TASK 3</b>	<b>Design</b>										\$26,513	<b>\$60,159</b>
	<i>Revise Existing Drawings</i>						0					
	G-1 Title Sheet			2	2		4	\$610	\$0		\$0	\$610
	D-1 Existing Site Demolition Plan		1	2	8		11	\$1,680	\$0		\$0	\$1,680
	D-2 Existing Pump Station Demolition Plan			2	6		8	\$1,170	\$0		\$0	\$1,170
	C-1 Proposed Site Layout and Grading Plan		2	4	16		22	\$3,360	\$0		\$0	\$3,360
	M-1 Proposed Pump Station Building Plan		4	8	30		42	\$6,440	\$0		\$0	\$6,440
	M-2 Proposed Pump Station Sections and Details		2	4	16		22	\$3,360	\$0		\$0	\$3,360
	M-3 Proposed Pump Station Building Elevations 1		2	4	12		18	\$2,800	\$0		\$0	\$2,800
	M-4 Proposed Pump Station Building Elevations 2		1	4	12		17	\$2,570	\$0		\$0	\$2,570
	MD-3 Mechanical Details			2	4		6	\$890	\$0		\$0	\$890
	S-4 Foundation Plan S-5				0.2		0.2	\$28	\$0	\$2,100	\$0	\$2,128
	S-5 Structural Details				0.2		0.2	\$28	\$0	\$2,100	\$0	\$2,128
	E-1 Standard Electrical Symbols & Abbreviations				0.2		0.2	\$28	\$0		\$105	\$133
	E-2 Electrical Site Plan		1		0.2		1.2	\$258	\$0		\$2,048	\$2,306
	E-3 Single Line Diagram E-4 Elevations		1		0.2		1.2	\$258	\$0		\$2,100	\$2,358
	E-4 Elevations				0.2		0.2	\$28	\$0		\$2,100	\$2,128
	E-5 Pump Station Power and Signal Plan		2		0.2		2.2	\$488	\$0		\$8,610	\$9,098
	E-6 Pump Station Lighting and Receptacle Plan		1		0.2		1.2	\$258	\$0		\$2,100	\$2,358
	E-7 Controls 1				0.2		0.2	\$28	\$0		\$105	\$133
	E-8 Controls 2				0.2		0.2	\$28	\$0		\$105	\$133
	E-9 Electrical Schedules E-10 Electrical Details		1		0.2		1.2	\$258	\$0		\$2,100	\$2,358
	E-10 Electrical Details				0.2		0.2	\$28	\$0		\$105	\$133
	E-11 Electrical Demolition Plan E-12 RTU Controls		1		0.2		1.2	\$258	\$0		\$2,100	\$2,358
	E-12 RTU Controls				0.2		0.2	\$28	\$0		\$105	\$133
	E13- RTU Layout				0.2		0.2	\$28	\$0		\$105	\$133
	I-1 Standard P&ID Symbols and Abbreviations				0.2		0.2	\$28	\$0		\$105	\$133
	I-2 P&ID 1				0.2		0.2	\$28	\$0		\$315	\$133
	I-3 Pump Station P&ID		1	2	6		9	\$1,400	\$0		\$315	\$1,715
	I-4 Pump Station P&ID				0.2		0.2	\$28	\$0		\$315	\$343
	I-5 System Architecture				0.2		0.2	\$28	\$0		\$315	\$343
	<i>Revise Existing Specifications</i>											
	Front End, Division 1, and Mechanical			28		2	30	\$4,816	\$0			\$4,816
	Division 16 & 17					1	1	\$98			\$1,680	\$1,778
<b>TASK 4</b>	<b>SDG&amp;E coordination</b>										\$840	<b>\$1,070</b>
	Coordination		1				1	\$230	\$0		\$840	\$1,070
<b>TASK 5</b>	<b>Construction Cost Opinion</b>										\$840	<b>\$2,160</b>
	Compile Construction Costs			8			8	\$1,320	\$0		\$840	\$2,160
		0.00	32.00	78.00	115.80	9.00	234.80	\$37,324				
		\$0	\$7,360	\$12,870	\$16,212	\$882		\$37,324	\$0	\$4,200	\$29,513	<b>\$70,827</b>

**TOTAL NOT-TO-EXCEED FEE (without authorization): \$70,827**

**NOTES:**

1. Subconsult Fees include a 5% markup.



**RAINBOW MWD 2017 RATES  
HOURLY CHARGE RATE AND  
EXPENSE REIMBURSEMENT SCHEDULE**

**Professional**

Engineering Intern/Technician .....	\$ 75
CADD Designer I/Engineer I .....	\$ 125
Graphic Designer .....	\$ 130
CADD Designer II/Engineer II .....	\$ 140
CADD Designer III/Engineer III .....	\$ 150
Designer/Project Engineer .....	\$ 165
Senior Project Engineer .....	\$ 180
Senior Project Engineer Planning & IS .....	\$ 195
Project Manager .....	\$ 215
Senior Project Manager .....	\$ 230
Principal .....	\$ 245
Principal Planning & IS .....	\$ 245

**Surveying**

Principal Surveyor .....	\$ 165
Project Surveyor .....	\$ 140
Field – 2 Man Crew .....	\$ 250
Survey Assistant I .....	\$ 120

**Surveying-Equipment Rental**

GPS	
Daily .....	\$ 320
Weekly .....	\$ 1,100
Monthly Rate .....	\$ 3,200
Total Station	
Daily .....	\$ 140
Weekly .....	\$ 550
Monthly .....	\$ 1,560
Robotic Total Station	
Daily .....	\$ 350
Weekly .....	\$ 1,210
Monthly .....	\$ 3,440

**Environmental**

Intern/Technician .....	\$ 75
Env Specialist I/Project Coord I .....	\$ 115
Technical Editor .....	\$ 105
Lead Technical Editor .....	\$ 125
Graphic Artist .....	\$ 118
Env Specialist II/Project Coord II .....	\$ 140
Env Specialist III/Project Coord III .....	\$ 155
Project Manager I .....	\$ 165
Project Manager II .....	\$ 177
Senior Technical Staff .....	\$ 190
Senior Project Manager .....	\$ 220
Principal .....	\$ 230

**Construction\***

Construction Inspector .....	\$ 128
Senior Construction Inspector .....	\$ 141
Resident Engineer .....	\$ 158
Construction Manager .....	\$ 180
Sr. Construction Manager .....	\$ 205
CM Coordinator .....	\$ 115
Asst CM Coordinator .....	\$ 95

**Flow Monitoring**

Field Tech I .....	\$ 75
Field Tech II .....	\$ 95
Field Tech III .....	\$ 105
Field Supervisor .....	\$ 118
Field Operations Manager .....	\$ 145
Project/Data Manager .....	\$ 160

**Administrative**

Administrative Clerk .....	\$ 75
Word Processor/Admin Support .....	\$ 98

Sub-consultants will be billed at cost plus 10% unless specified otherwise in the agreement.

All base rates will escalate by 3% per annum.

**Reimbursable Costs**

Reproduction, special photography, postage, delivery services, express mail, printing, travel, parking, and any other specialty services performed by subcontractor will be billed at cost plus 15%.

Mileage will be billed at the current IRS allowed rate.

\* Field personnel rates are inclusive of vehicle, mileage, phone, computer, etc. Inspection rates shown are for prevailing wage projects. Inspection rates for non-prevailing wage contracts are \$15 dollars an hour less than the listed rate. Inspection rates for overtime are \$30 dollars an hour more than the listed rate.



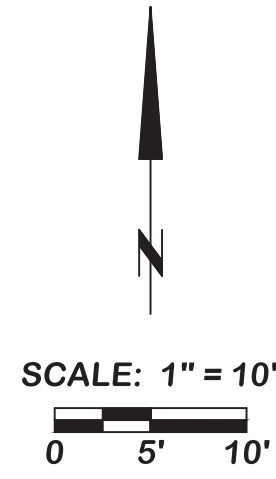

SCALE: 1" = 10'  
0 5' 10'

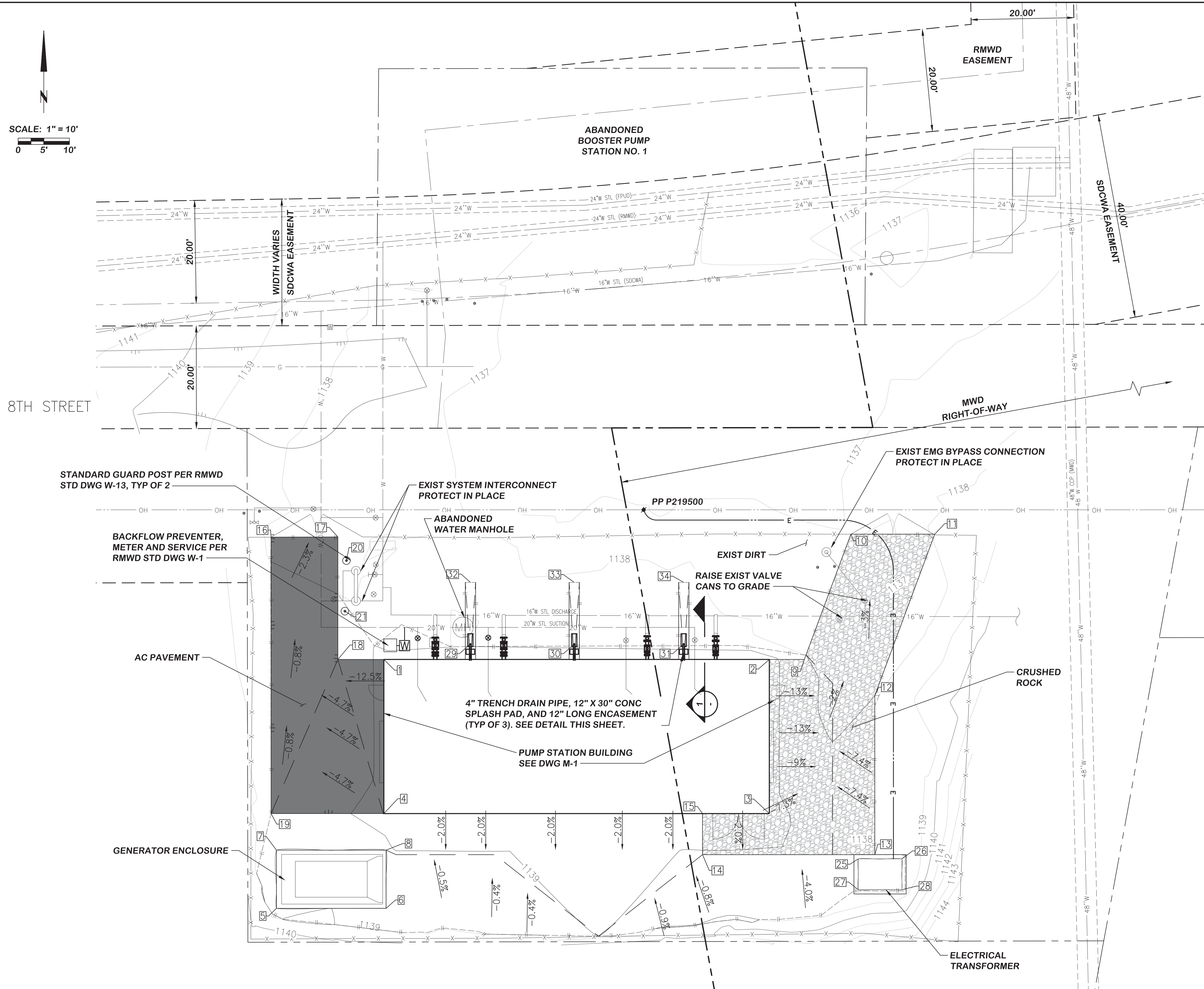

COORDINATE TABLE				
NO	NORTHING	EASTING	ELEVATION	DESCRIPTION
1	2094030.41	6289664.03	1139.25	FG @ BLDG & GRAVEL
2	2094030.41	6289739.03	1139.25	FG @ BLDG & AC
3	2094000.41	6289739.03	1139.25	FG @ BLDG & AC
4	2094000.41	6289664.03	1139.25	FG @ BLDG & GRAVEL
5	2093981.97	6289643.13	0.00	FG @ PAD
6	2093981.97	6289664.46	0.00	FG @ PAD
7	2093993.30	6289643.13	0.00	FG @ PAD
8	2093993.30	6289664.46	0.00	FG @ PAD
9	2094030.41	6289745.84	1138.14	AC
10	2094054.79	6289754.90	1137.55	AC
11	2094054.79	6289771.22	1138.13	AC
12	2094023.38	6289759.55	1138.00	AC
13	2093992.41	6289759.55	1138.80	AC
14	2093992.41	6289726.03	1138.90	AC
15	2094000.41	6289726.02	1139.25	FG @ BLDG & AC
16	2094054.21	6289642.07	1137.81	GRAVEL
17	2094054.25	6289655.07	1137.77	GRAVEL
18	2094030.41	6289655.07	1138.14	GRAVEL
19	2094000.41	6289642.07	1138.39	GRAVEL
20	2094049.66	6289656.74	1137.87	BOLLARD
21	2094039.81	6289656.43	1138.04	BOLLARD
25	2093991.60	6289756.32	1138.82	FG @ PAD
26	2093991.60	6289764.82	1138.82	FG @ PAD
27	2093985.60	6289756.32	1138.85	FG @ PAD
28	2093985.60	6289764.82	1138.85	FG @ PAD
29	2094033.41	6289680.86	1138.47	DRAIN IE
30	2094033.41	6289701.08	1138.47	DRAIN IE
31	2094033.41	6289722.36	1138.47	DRAIN IE
32	2094045.41	6289680.88	1138.21	FL
33	2094045.41	6289701.07	1138.17	FL
34	2094045.41	6289722.38	1138.12	FL

NOTES:

- 6" OF CRUSHED ROCK INSTALLED OVER 12" SUBGRADE, COMPACTED TO 90%
- SOIL STERILANT SHALL BE APPLIED TO COMPACTED SUBGRADE PRIOR TO PLACEMENT OF CRUSHED ROCK.
- RELOCATE EXIST GRAVEL ON-SITE PRIOR TO GRADING. EXIST GRAVEL TO BE DISTRIBUTED AFTER GRADING TO ALL LOCATIONS NOT INDICATED FOR PAVEMENT OR CRUSHED ROCK.

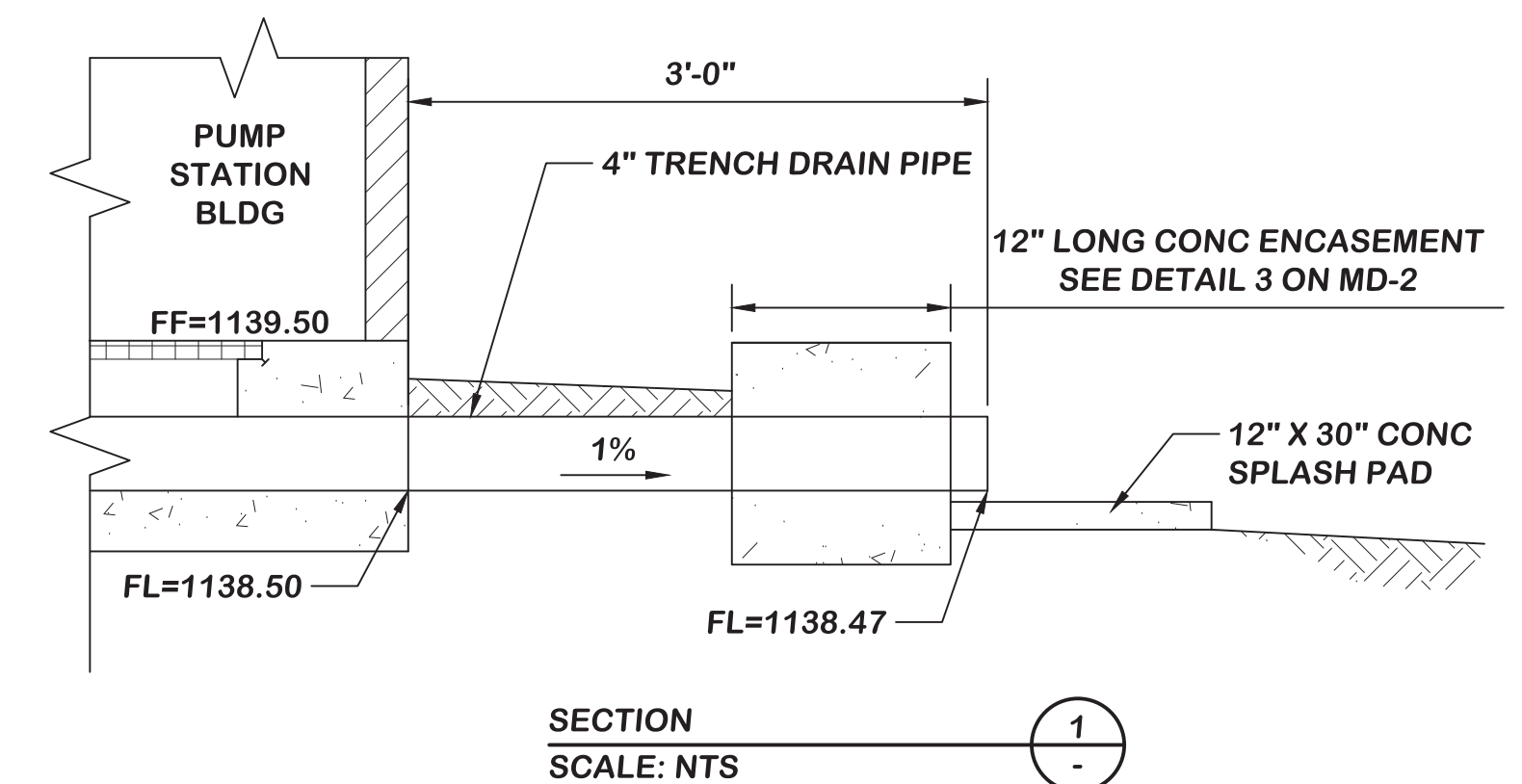

**DIGALERT**  
DIAL TOLL FREE 811  
AT LEAST TWO DAYS BEFORE YOU DIG  
UNDERGROUND SERVICE ALERT OF SOUTHERN CALIFORNIA

NO.	DESCRIPTION	DATE	APPROVED

DESIGNED BY: RWM  
DRAWN BY: ARW  
CHECKED BY: RHK

**Infrastructure**  
ENGINEERING CORPORATION  
14271 Danielson Street  
Portland, Oregon 97206  
T 858.413.2400 F 858.413.2440  
www.iecorporation.com

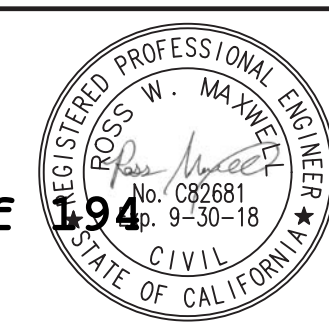

**RAINBOW**  
MUNICIPAL WATER DISTRICT  
Committed to Excellence

**RAINBOW HEIGHTS PUMP STATION REHABILITATION**  
**PROPOSED SITE LAYOUT & GRADING PLAN**

DRAWING NO: **C-1**  
SHEET NO: **6 OF 36**  
PROJECT NO: **600-60001**

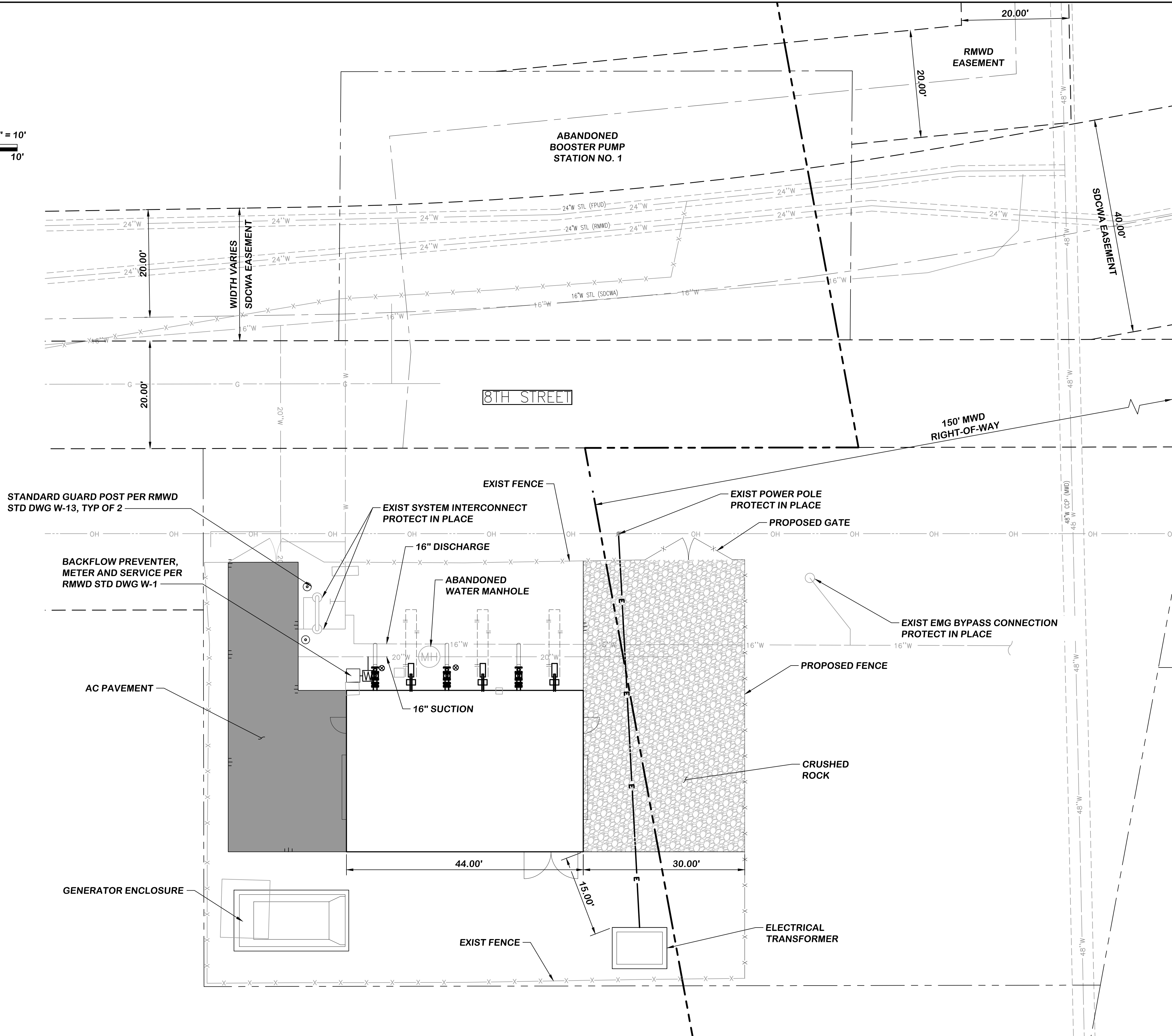
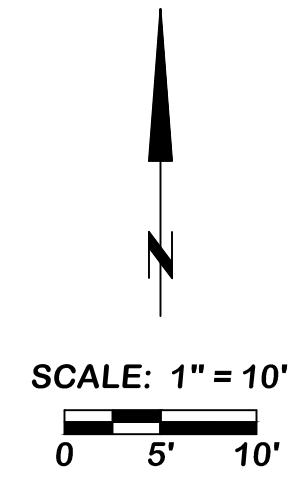
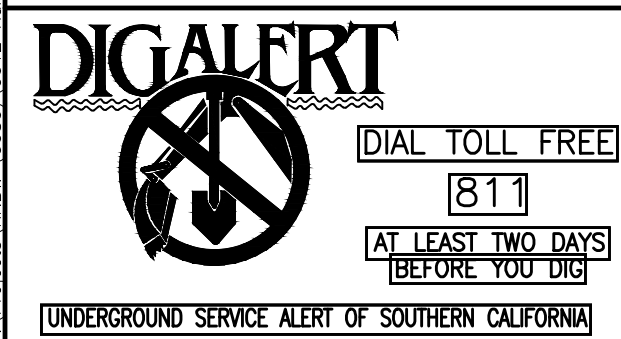

FIGURE 2



NO.	DESCRIPTION	DATE	APPROVED

DESIGNED BY:  
RWM  
DRAWN BY:  
ARW  
CHECKED BY:  
RHK

**Infrastructure**  
ENGINEERING CORPORATION  
14271 Danielson Street  
P.O. Box 13920  
T 858.413.2400 F 858.413.2440  
www.iecorporation.com



**RAINBOW HEIGHTS PUMP STATION REHABILITATION**  
**PROPOSED SITE LAYOUT & GRADING PLAN**

DRAWING NO:  
**C-1**  
SHEET NO:  
**6 OF 36**  
PROJECT NO:  
**600-600001**

P:\Projects\2018\02\20180212\_Rainbow\_Height\_Pump\_Station\_Rehabilitation\Drawings\18-03-12-Exhibit-C-01.dwg - 03/15/2018 16:12  
 P:\Projects\2018\02\20180212\_Rainbow\_Height\_Pump\_Station\_Rehabilitation\Drawings\18-03-12-Exhibit-C-01.dwg - 03/15/2018 16:12



## MEETINGS/SEMINARS/CONFERENCES/WORKSHOPS

<b>VARIABLE</b>					
<b>DATE</b>	<b>2018</b>	<b>MEETING</b>	<b>LOCATION</b>	<b>ATTENDEES</b>	<b>POST</b>
June	14	SDCWA Special Board Meeting	SDCWA	GM	N/A
June	*	CSDA – San Diego Chapter	(Location to be Announced) 6:00 p.m.	Mack	N/A
June	*	LAFCO Special Meeting	County Admin Center, Room 302 – 9:30am	(As Advised by GM)	N/A
June	*	Santa Margarita River Watershed Watermaster Steering Committee	Rancho California Water District	Hamilton	N/A

\* To Be Announced

## MEETINGS/SEMINARS/CONFERENCES/WORKSHOPS

<b>RECURRING</b>					
<b>DATE</b>	<b>2018</b>	<b>MEETING</b>	<b>LOCATION</b>	<b>ATTENDEES</b>	<b>POST</b>
June	4	LAFCO	County Admin. Center Room 302 9:00 am	As Advised by GM	N/A
June	6	Engineering Committee Meeting	RMWD Board Room 3:00 p.m.	Appointed Director, General Manager	5/30
June	7	Communications Committee Mtg.	RMWD Board Room 3:30 p.m.	Appointed Director, General Manager	5/30
June	12	Budget & Finance Committee Mtg.	RMWD Board Room 1:00 p.m.	Appointed Director, General Manager	4/26
June	15	NC Managers	Golden Egg 7:45 a.m.	General Manager	N/A
June	19	SDCWA GM's Meeting	SDCWA, San Diego 9:30 a.m.	General Manager	N/A
June	19	Council of Water Utilities	Hotel Karlan 14455 Penasquitos Drive San Diego 7:15 a.m. Poway	All Directors, General Manager	N/A
June	26	RMWD General Board	RMWD Board Room (Start Time to Be Determined)	All Directors	6/21
June	27	North County Water Group	Rincon Del Diablo, Escondido 7:30 a.m.	All Directors on a Rotating Schedule, General Manager	N/A
June	27	San Luis Rey Watershed Council	Pala Administration Building 1:00 p.m.	Stewart	N/A
June	28	SDCWA Full Board Meeting	SDCWA Board Room, 3-5 p.m.	General Manager	N/A

**BOARD OF DIRECTORS**

May 22, 2018

---

**SUBJECT**

Operations Report for April 2018

---

**DESCRIPTION**

Activities for Operations & Maintenance Division

---

**CONSTRUCTION & MAINTENANCE DEPARTMENT:**

The Construction Crews repaired five (5) leaks, two (2) main line repairs, two (2) services and one (1) appurtenance. The crew performed three (3) planned/emergency shutdowns. They also began the installation of the new pressure station at Ascot Park. The department installed one (1) 8” and replaced one (1) 6” gate valve. The crew prepped for a new 8” plug valve for the new water main on Sagewood. The crew maintained District easements as well as completed work within the District Yard.

**WATER OPERATIONS & VALVE MAINTENANCE DEPARTMENT:**

<b>Monthly Totals</b>	<b>Valves (Distribution)</b>	<b>Appurtenance Valves</b>	<b>Appurtenances</b>
<b>Exercised</b>	41	66	N/A
<b>Inoperable</b>	0	0	5
<b>Repaired</b>	0	0	0
<b>Replaced</b>	1	0	5
<b>Installed</b>	1	0	0

Water Operations completed and/or oversaw the following:

- Completed thirteen (13) monthly tank inspections and three (3) reservoir cover inspections
- Assisted with and/or performed five (6) water quality complaints
- Completed maintenance/cleaning and/or repairs to four (4) pressure stations
- Canonita Tank was removed from service for re-coating inside
- Hutton and Turner Tanks were cleaned and disinfected

Valve Maintenance completed and/or oversaw the following:

- 177 utility locates completed
- Assisted with 9 shutdowns and 1 leak repair
- Located easements in Lilac Fire area
- Replaced three (3) fire hydrants
- Replaced one (1) air vac / one (1) wharf-head

## WASTEWATER DEPARTMENT:

### Monthly, Semi Annual and Annual Reports:

California Integrated Water Quality System (CIWQS): Confirmation #2515375 Reported "No Spill Report" for month of April 2018.

'NON-District Affiliated' – April 23, 2018 California Integrated Water Quality System (CIWQS): Event #846673 Reportable Sanitary Sewer Overflow (SSO) under Order #2006-0003 State Water Resources Control Board - Address: 5816 Lake Vista Drive Bonsall (Private 3" abs sewer lateral release Category 1).

### Lift Stations Pumps / Preventative Maintenance:

March 30, 2018: Monthly sample at Stallion flow meter.

April 25, 2018: Performed 9 sample locations for Total Suspended Solids (TSS) on collection system.

### Flow Meter Demo - Hach Company:

Continuing demo trial per Engineering – April 2018 (Monitor sewer flow) / Capturing upstream flows from Pala Mesa / Set up confined space entry and set-up of flow meter.

### Sewer Line Cleaning:

March 29, 2018 – April 4, 2018 = 5,640'

April 5, 2018 – April 11, 2018 = 4,438'

April 12, 2018 – April 18, 2018 = 2,130'

April 19, 2018 – April 25, 2018 = 310

April 26, 2018 – May 2, 2018 = 3,395

Total footage cleaned for March = **15,193'**

### High Frequency:

March 29, 2018 – April 4, 2018 = 1,161'

April 05, 2018 – April 11, 2018 = 875'

April 12, 2018 – April 18, 2018 = 2,265'

April 19, 2018 – April 25, 2018 = 254'

April 26, 2018 – May 2, 2018 = 1,410'

Total High Frequency footage cleaned: **5,965'**

### Manhole Inspections:

March 29, 2018 – April 4, 2018 = 26 manholes inspected

April 5, 2018 – April 11, 2018 = 22 manholes inspected

April 12, 2018 – April 18, 2018 = 49 manholes inspected

April 19, 2018 – April 25, 2018 = 38 manholes inspected

April 26, 2018 – May 2, 2018 = 43 manholes inspected

Total manholes inspected for month: **178**

### CCTV/CONTRACTOR:

March 29, 2018 – April 4, 2018 = 459'

April 12, 2018 – April 18, 2018 = 7,900'

April 19, 2018 – April 25 ,2018 = 9,659'

April 26, 2018 – May 2, 2018 = 7,885'

Total sewer lines CCTV: **25,903'**

Smart/Cover Alarm Units:

April 1, 2018 – High level (Siphon)

April 23, 2018 – High level alarm (Siphon)

**TECHNICAL SERVICES DEPARTMENT:**

Fleet/Garage:

Repairs, maintenance or priority inspections for the month of April 2018:

- Vehicle maintenance (3)
- Vehicles with emergency repairs (3)
- Small equipment repairs (6)
- New vehicle preparation (1)
- Off-road equipment / trailer repairs & maintenance (5)
- Off-road equipment / trailer emergency repairs (1)
- Large vehicles maintenance / repairs (1)
- Large equipment emergency repairs (1)
- Safety recalls (0)
- BIT Inspections (16)
- Decommission of vehicles and prepared for GovDeals auction (0)
- Gasboy fuel cube installation, maintenance or troubleshoot (8)
- Gasboy fuel trouble-shooting (1)
- Scheduled crane inspections (0)

Water Quality:

- 22 - Distribution system coliform monitoring
- 16 - Water quality calls
- 2 - Special Bac-T samples for tanks (Turner/Hutton)
- 15 - Nitrification samples
- 453 - Backflow tests/inspections completed
- Submitted Annual Discharge Permit (NPDES)
- Submitted Draft 2017 CCR to DDW for review

## Electrical/SCADA:

Status update provided below on District-wide projects supported by Electrical/SCADA Staff:

- Flow meters at Gopher, Turner, Hutton Tanks and Morro Reservoir: Ongoing
- TDS Meter temporary install at Gopher Tank for testing: Meter is installed and communicating
- Motor control maintenance at Lift Station #3: Ongoing
- Motor control maintenance at Lift Station #2 (Old River Road): Ongoing
- Motor control maintenance at Rainbow Hills Pump Station: Ongoing
- Security light installation at Gomez Pump Station: Ongoing
- Mechanic Shop sub-panel installation and circuits to tire balancer and vehicle hoist: Complete
- Engineering Office Trailer: Complete
- New SCADA panel installation at Gopher Tank: Complete
- New Gopher Tank radio equipment installation: Complete
- Cement Tank relocation of SCADA equipment: Ongoing

## **EMPLOYEE RECOGNITION – OPERATIONS & MAINTENANCE DIVISION**

### ***District's Monthly "Excellence Program" Coin Award Winners***

- None awarded for this month

### ***Special Awards Received***

- Employer Support of the Guard & Reserve (ESGR) recognized the following Board Members, General Manager and staff for their efforts in supporting employees for their military commitments:

#### *Above & Beyond Award Recipient:*

- Board of Directors

#### *7 Seals Award Recipient:*

- Tom Kennedy

#### *Patriot Award Recipients:*

- John Maccarrone
- Marc Walker
- Ramon Zuniga
- Ken Gerdes
- Michael Powers
- Vanessa Martinez
- Karleen Harp

### ***New Certifications***

- Gerardo Cancino received the following certifications:
  - Water Treatment Operator 2
  - Water Distribution Operator 3



---

Darren S. Milner  
Operations Manager

5/22/18

**BOARD OF DIRECTORS**

May 22, 2018

---

**SUBJECT**

Engineering Report for April 2018

---

**DESCRIPTION**

---

**CAPITAL PROJECTS:**

Bonsall Basin Imported Return Flow: Consultant is working on updating the Imported Return Flow model and confirming legal water rights.

Condition Assessment of Water Facilities: The Consultant has submitted a final draft of the technical memorandum.

Gird to Monserate Hill: Final plans, specs and environmental documents reviewed by staff. Pursuing alternative design with lower construction cost.

Horse Creek Lift Station: The Lift Station is scheduled to be completed by the end of June 2018.

Lift Station 1 Replacement: New design underway with equalization basin at Thoroughbred Lift Station site and Schoolhouse Lift Station.

Moosa Crest Waterline (Emergency) Project: Received all unconditional releases from the contractor and retention was released for payment.

Rainbow Height's Pump Station Rehabilitation: Metropolitan Water District denied working in their easement. Staff submitted alternatives/redesign for smaller station. Received redesign proposal for smaller pump station. Advertise for bids in Summer 2018.

Wastewater Outfall Replacement: Project on hold until further evaluation from local water alternatives. Project may take the form of rehabilitation with equalization basin.

Weese Filtration Plant Interconnect: IEC submitted the 90% design. Staff comments to be submitted by May 16, 2018. Final design due in June 2018.

**DEVELOPER PROJECTS:**

Golf Green Estates (Development Solutions): 94 SFR / 102.46 EDUs - Planned across from Bonsall Elementary School on Old River Road. Contractor completed installing all the below ground water and sewer main. CCTV needs to be completed for sewer. Models completed and 23 water meters purchased to date.

Horse Creek Ridge (D.R. Horton): 751 WMs / 754 EDUs - Off of Highway 76 and Horse Ranch Creek Road. Models completed and 240 water meters purchased to date.

Malabar Ranch (Davidson Communities): 31 SFR / 29 EDUs - Off of Via Monserate/La Canada. There are 17 out of 31 homes built. Contractor completing waterline relocation and punch list items.

Nessy Burger: Nessy Burger is constructing a permanent building. Staff is working with owners on options concerning the wastewater disposal. Possible options would be to upgrade the existing private lift station or construct a lateral to the sewer main being constructed in Old Highway 395 to serve Pala Mesa Highlands.

Pala Mesa Highlands (Beazer Homes): 124 SFR / 124 EDUs - On Old Highway 395. Contractor has been installing 8" and 12" water and sewer mains. Sewer service agreement approved at the April 2018 Board Meeting. Models expected by Summer 2018 and 2 irrigations meters purchased to date.

Palomar College: 1 WM / 100 EDUs - Sewer service agreement approved at the April 2018 Board Meeting. Sewerline construction completed to connection point. Connection to existing sewer is scheduled after the Horse Creek Lift Station is completed and operational. Waterline construction completed. Palomar's 4" water meter has been installed.

Topa Topa Place (Frulla Inc.): Waterline relocation. Construction agreement was executed on April 13, 2018. Staff reviewing submittals.

**OTHER:**

ITEMS	NO#	ITEMS	NO#
Water Availability Letters	2	Water Meters Purchased	19
Sewer Availability Letters	2	Sewer EDUs Purchased	0
Water Commitment Letters	0	Developer Shutdowns	0
Sewer Commitment Letters	0	Jobs Closed: Highway 76 E. Seg.	1

  
 Michael Powers, P.E. 5/22/18  
 Associate Engineer



**BOARD OF DIRECTORS**

April 10, 2018

**SUBJECT**

March: Customer Service & Meter Services

**DESCRIPTION**

**METER SERVICES:**

Meter Services completed 887 service orders. Here is a summary of the most pertinent service orders shown by category.

SERVICE ORDERS	COMPLETED
Check Reads	450
Transfers	76
Locked	36
Unlocked	29
Pressure Calls	19
Leaks	20
Drought	2

**CUSTOMER SERVICE:**

SERVICE ORDERS	COMPLETED
Lockbox Payments (mailed-in)	2,149
Online Payments	1127
Recurring Online Payments	1503
Locked for Non-Payment	27
48 Hour Notices	71
Cycle 01 Billing Service Orders	157
Cycle 02 Billing Service Orders	152
Cycle 03 Billing Service Orders	117

SERVICE ORDERS	COMPLETED
Courtesy Calls Cycle 01	87
Courtesy Calls Cycle 02	76
Courtesy Calls Cycle 03	89
Shut Off Notices Cycle 01	29
Shut Off Notices Cycle 02	41
Shut Off Notices Cycle 03	42



Vanessa Martinez  
Finance Manager

5/08/2018



Kenny Diaz  
Meter Services Crew Leader

5/08/2018



**BOARD OF DIRECTORS**

April 10, 2018

**SUBJECT**

April: Customer Service & Meter Services

**DESCRIPTION**

**METER SERVICES:**

Meter Services completed 592 service orders. Here is a summary of the most pertinent service orders shown by category.

SERVICE ORDERS	COMPLETED
Check Reads	228
Transfers	72
Locked	27
Unlocked	28
Pressure Calls	19
Leaks	34
Drought	2

**CUSTOMER SERVICE:**

SERVICE ORDERS	COMPLETED
Lockbox Payments (mailed-in)	1,993
Online Payments	1364
Recurring Online Payments	1154
Locked for Non-Payment	27
48 Hour Notices	71
Cycle 01 Billing Service Orders	66
Cycle 02 Billing Service Orders	70
Cycle 03 Billing Service Orders	80

SERVICE ORDERS	COMPLETED
Courtesy Calls Cycle 01	109
Courtesy Calls Cycle 02	76
Courtesy Calls Cycle 03	96
Shut Off Notices Cycle 01	42
Shut Off Notices Cycle 02	29
Shut Off Notices Cycle 03	37



Vanessa Martinez  
Finance Manager

5/08/2018



Kenny Diaz  
Meter Services Crew Leader

5/08/2018





## BOARD INFORMATION

### BOARD OF DIRECTORS

May 22, 2018

---

#### SUBJECT

HUMAN RESOURCES REPORT FOR APRIL/MAY 2018

---

#### DESCRIPTION

Personnel changes, human resources activities, and safety report for April/May 2018

---

#### STAFFING AND PERSONNEL CHANGES:

- One Construction Utility Worker III left the District on April 23, 2018.
- One Construction Utility Worker II began a leave of absence that is expected to last until July.
- One Customer Service Representative will temporarily transfer to construction while the District recruits for a full-time replacement.
- A temporary Customer Service Representative will be contracted to backfill the vacancy created by the transfer to construction.

#### **Environmental Health and Safety Officer**

Charmaine Esnard started with the District on May 14, 2018. Ms. Esnard is a 22-year veteran of the United States Marine Corps, where her assignments included Power Plants Division Chief and Ground Safety Manager at MCAS Miramar.

#### **District Engineer**

Steven Strapac is scheduled to start on June 11, 2018. Mr. Strapac is a licensed Professional Engineer (PE) and Land Surveyor, who is also a rate-payer of the District, and served on the Engineering Committee from 2008-2015. Most recently he was City Engineer for the City of Oceanside, and has served the cities of Poway, Rancho Santa Margarita, Moreno Valley, and El Cerrito in various contract and full-time public works administration and civil engineering roles.

#### **Lead Operator**

The promotional opportunity for the newly created Lead Operator position was posted and two employees applied for the position. Interviews were scheduled for May 10, 2018.

## **EMPLOYEE RECOGNITION:**

### **Excellence Coin Awards**

The following coin was issued in April:

#### **Responsibility**

**Ahmed Khattab** - The GM has tasked Rainbow and Nobel to enter 480 inoperable valves that were discovered and documented by the valve maintenance team into the EAM system. The task of entering them individually would have taken a substantial amount of labor hours. Ahmed, took the information and moved the data into the Infor system, producing over 480 individual work orders. Ahmed's extensive knowledge of EAM and code writing allowed the mission to be completed quickly and efficiently, saving a substantial amount of team hours.

#### **Teamwork**

**Chris Hoelscher, Chris Waite, Kenny Diaz** – During this year's "Price of Water" presentation at Bonsall High School for the demonstration portion of the program we were unable to utilize the conservation district staff. With very little notice, they stepped up to the plate, created an activity sheet for the students and put on several educational and captivating demonstrations for over 100 students. Their willingness to work outside their normal roles, make time in their busy schedules and put in an amazing amount of effort to instruct and educate students on water use efficiencies and minimizing water loss exceeded my expectations. Without their assistance and accommodating spirit this year's program would not have been the success that it was.

#### **Professionalism**

**Justin Demary** - At the Avocado Festival, a customer approached the booth specifically to compliment Justin Demary for his diplomacy during a leak. He had responded after hours while on Standby. Their neighbor had a leak that was going to undermine their driveway. The neighbor didn't want to fix it because it was minor, but Justin explained that it would get worse over time and would be less expensive to fix it before it caused damage to the neighbor's driveway. He convinced the neighbor to fix it and avoided a dispute. The customer was very impressed with his diplomacy in this situation.

## **EMPLOYEE EVENTS:**

### **Inaugural Take Your Kids to Work Day and Family Health Fair– April 26, 2018**

This was the first time the District invited families to see what our employees do every day and learn about our jobs. Nearly 30 kids and many spouses participated in the event. Employees from all areas of the District contributed to making the event highly successful:

**Cynthia Gray** - Planned logistics of event schedule, directed and led rehearsals of department presentations, designed the tour format, ensured the District grounds and buildings were clean and presentable, and presented an over view of the District to kick off the event.

**Karleen Harp** - Planned Health Fair portion of event and lunch for employees and families, co-planned the event schedule and tour logistics, and presented the District's values and coin program to families.

**Dawn Washburn, Jerry Kraft, Chris Waite, and Laura Martinez** – Acted as tour guides for the family members who participated in the event to ensure each group stayed on schedule and in authorized areas to keep everyone safe.

**Ramon Zuniga and Wastewater Crew** – Presented to families and demonstrated how the sewer lines get cleaned, what the vac truck does, and what happens if you flush a toy or other debris.

**Bryan Rose and Scott Simpson** - Demonstrated how we use valves to control the flow of water, how we freeze a line.

**Kenny Diaz and Justin Chandler**– Demonstrated what meters do, and all the meter sizes we have at the District.

**Kyle Schilling and Wayne Nault** – Demonstrated our welding shop, what welders do, and the importance of personal protective equipment to stay safe at all times.

**Justin Demary and Carlos Ramos** – Showed families the dump truck and backhoe, and allowed kids to take photos sitting in the trucks.

**Rene Del Rio** – Discussed fleet vehicle maintenance.

**Marc Walker and Ed Bradley** – Demonstrated how the SCADA system works and how they use it to monitor and control the flow of water.

**Michael Powers** – Showed families what engineering plans look like, and how to identify water lines, sewer lines, and manholes on the plans.

### **NEOGOV:**

#### **Insight Module**

We currently have 2,190 active email subscriptions for notifications of job openings.

#### **Perform Module**

Due to turnover and a leave of absence of DREAM team members, meetings were delayed until new members were selected from one of the bargaining units. The next meetings are scheduled for May 16 and May 23, 2018.

### **LILAC FIRE UPDATE:**

The District has applied for and been approved for two FEMA grants. The District is having ongoing correspondence with California Office of Emergency Services to document associated project costs.

### **SAFETY:**

#### **Incidents**

A slip and fall incident was reported on May 4, 2018. There was no lost time or modified duty related to the incident.

#### **Safety Training**

Target Solutions online training: 10 completions for April 2018

#### **Tailgate Trainings**

Insect Awareness – 32 employees

Valve Machine to iPad – 22 employees

Working Hot Weather Awareness – 32 employees



---

Karleen Harp, COSM  
Human Resources Manager

05/22/2018





**Interim Financials**  
**Period: March 2018**



		Budget Amount	Period Amount	YTD Amount	YTD Variance	% Available
<b>Fund 01: Water</b>						
<b>Operating Revenues:</b>						
	Water Revenues	\$38,224,699	\$2,398,312	\$31,751,700	\$6,472,999	17%
	Other Revenues	\$536,500	\$170	\$309,988	\$226,512	42%
<b>Total Revenues:</b>		<b>\$38,761,199</b>	<b>\$2,398,482</b>	<b>\$32,061,688</b>	<b>\$6,699,511</b>	<b>17%</b>
<b>Operating Expenses:</b>						
	Cost of Water Sold	\$26,397,085	\$1,300,105	\$21,717,112	\$4,679,973	18%
	Labor	\$0	\$8,347	\$44,466	(\$44,466)	0%
	Overhead Transfer to General	\$3,843,297	\$0	\$0	\$3,843,297	100%
	Debt Service	\$1,120,142	\$0	\$0	\$1,120,142	100%
<b>Department Expenses</b>						
	Pumping					
	31 Labor	\$99,434	\$5,301	\$45,651	\$53,783	54%
	Expenses	\$590,500	\$37,493	\$364,365	\$226,135	38%
	Operations					
	32 Labor	\$1,180,319	\$119,804	\$829,416	\$350,903	30%
	Expenses	\$983,343	\$12,423	\$653,453	\$329,890	34%
	Valve Maintenance					
	33 Labor	\$479,381	\$33,615	\$273,019	\$206,362	43%
	Expenses	\$102,500	\$16,647	\$69,665	\$32,835	32%
	Water Distribution					
	34 Labor	\$1,480,763	\$134,230	\$965,740	\$515,023	35%
	Expenses	\$536,300	\$99,281	\$406,194	\$130,106	24%
	Meter Services					
	35 Labor	\$687,123	\$69,176	\$440,063	\$247,060	36%
	Expenses	\$409,000	\$75,396	\$294,547	\$114,453	28%
	Capital	\$145,000	\$30,831	\$319,802	(\$174,802)	0%
<b>Total Operating Expenses:</b>		<b>\$38,054,187</b>	<b>\$1,942,649</b>	<b>\$26,423,494</b>	<b>\$11,630,693</b>	<b>31%</b>
<b>Water Fund Totals:</b>		<b>\$707,012</b>	<b>\$455,833</b>	<b>\$5,638,195</b>	<b>\$4,931,183</b>	
<b>Fund 02: Wastewater</b>						
<b>Operating Revenues:</b>						
	Wastewater Revenues	\$2,395,500	\$211,366	\$1,979,478	\$416,022	17%
	Other Revenues	\$40,000	\$0	\$34,536	\$5,464	14%
<b>Total Revenues:</b>		<b>\$2,435,500</b>	<b>\$211,366</b>	<b>\$2,014,014</b>	<b>\$421,486</b>	<b>17%</b>
<b>Operating Expenses:</b>						
	Overhead Transfer to General	\$901,514	\$0	\$0	\$901,514	100%
<b>Department Expenses</b>						
	Wastewater					
	61 Labor	\$707,197	\$54,529	\$444,641	\$262,556	37%
	Expenses	\$1,418,000	\$43,960	\$166,100	\$1,251,900	88%
	Capital	\$25,000	\$0	\$10,340	\$14,660	59%
<b>Total Operating Expenses:</b>		<b>\$3,051,711</b>	<b>\$98,490</b>	<b>\$621,080</b>	<b>\$2,430,631</b>	<b>80%</b>
<b>Wastewater Fund Totals:</b>		<b>(\$616,211)</b>	<b>\$112,876</b>	<b>\$1,392,934</b>	<b>\$2,009,145</b>	

**Interim Financials**  
**Period: March 2018**



		<b>Budget Amount</b>	<b>Period Amount</b>	<b>YTD Amount</b>	<b>YTD Variance</b>	<b>% Available</b>
<b>Fund 03: General</b>						
<b>Operating Revenues:</b>						
	Overhead Transfers	\$4,744,811	\$0	\$0	\$4,744,811	100%
	Other Revenues	\$433,470	\$34,696	\$418,914	\$14,556	3%
	<b>Total Revenues:</b>	<b>\$5,178,281</b>	<b>\$34,696</b>	<b>\$418,914</b>	<b>\$4,759,367</b>	<b>92%</b>
<b>Operating Expenses:</b>						
	Other Expenses	\$0	\$85,523	\$256,608	(\$256,608)	0%
<b>Department Expenses</b>						
	Board of Directors					
	20 Labor	\$19,613	\$1,453	\$11,734	\$7,879	40%
	Expenses	\$20,300	\$839	\$10,570	\$9,730	48%
	Garage					
	36 Labor	\$147,989	\$12,887	\$97,457	\$50,532	34%
	Expenses	\$244,500	\$18,800	\$145,525	\$98,975	40%
	Capital	\$309,500	\$109,526	\$303,118	\$6,382	2%
	Administration					
	41 Labor	\$698,344	\$82,169	\$537,850	\$160,494	23%
	Expenses	\$1,271,978	\$106,938	\$1,193,758	\$78,220	6%
	Capital	\$100,000	\$0	\$95,184	\$4,816	5%
	Human Resources					
	42 Labor	\$171,149	\$21,382	\$109,727	\$61,422	36%
	Expenses	\$169,150	\$14,227	\$78,233	\$90,917	54%
	Safety					
	43 Labor	\$144,288	\$5,151	\$93,782	\$50,506	35%
	Expenses	\$76,350	\$2,163	\$42,736	\$33,614	44%
	Finance					
	51 Labor	\$522,628	\$50,694	\$353,292	\$169,336	32%
	Expenses	\$131,500	\$4,545	\$101,846	\$29,654	23%
	Customer Service					
	52 Labor	\$288,513	\$38,313	\$205,195	\$83,318	29%
	Expenses	\$239,500	\$17,895	\$183,966	\$55,534	23%
	Engineering					
	91 Labor	\$756,216	\$67,630	\$450,565	\$305,651	40%
	Expenses	\$325,529	\$31,220	\$305,560	\$19,969	6%
	<b>Total Operating Expenses:</b>	<b>\$5,637,047</b>	<b>\$671,357</b>	<b>\$4,576,707</b>	<b>\$1,060,340</b>	<b>19%</b>
	<b>General Fund Totals:</b>	<b>(\$458,766)</b>	<b>(\$636,660)</b>	<b>(\$4,157,793)</b>	<b>(\$3,699,027)</b>	
	<b>Net Income</b>	<b>(\$367,965)</b>	<b>(\$67,951)</b>	<b>\$2,873,336</b>	<b>\$3,241,301</b>	

# YTD Labor Costs (March 2018)

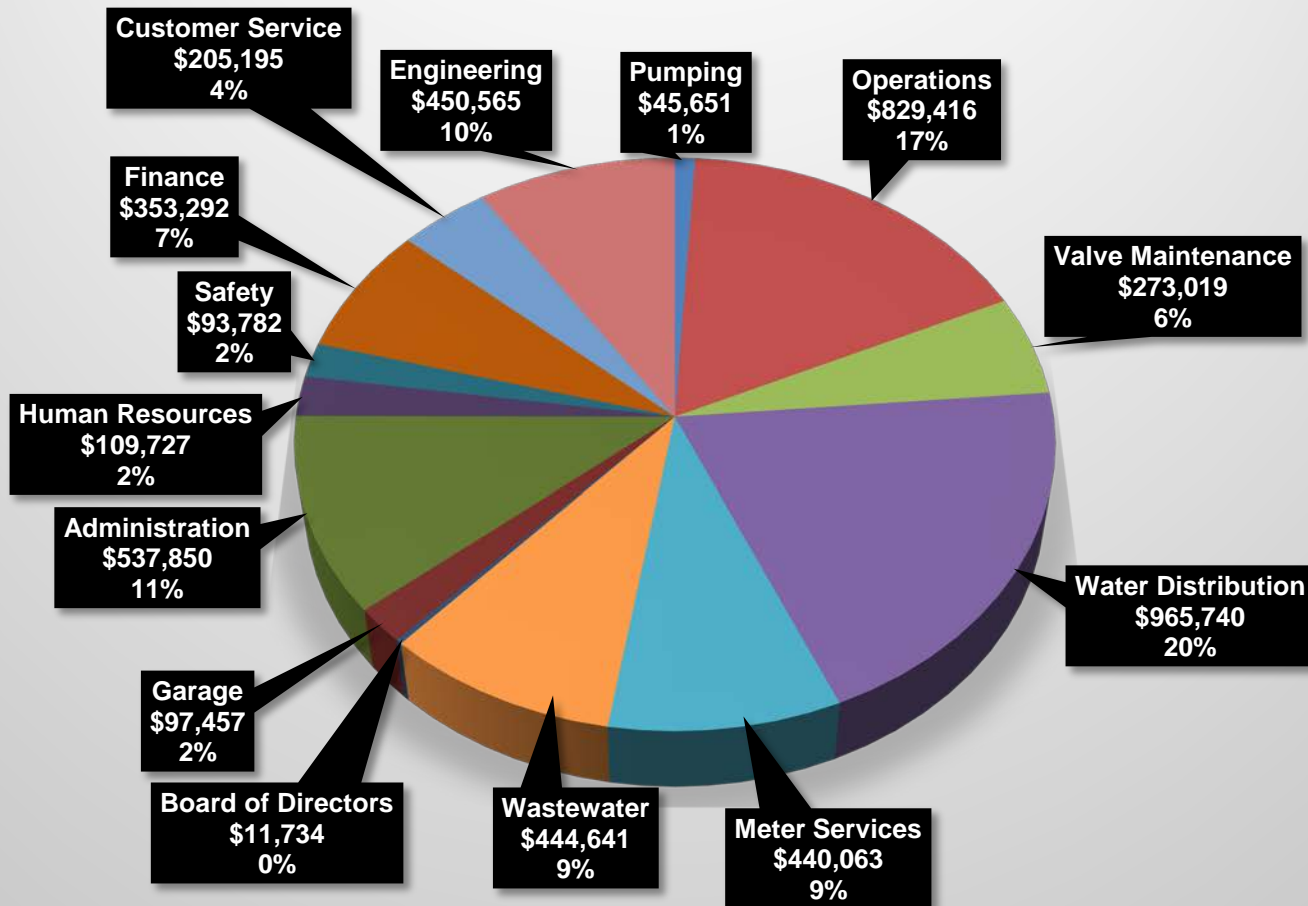

# YTD Expense Allocation (March 2018)

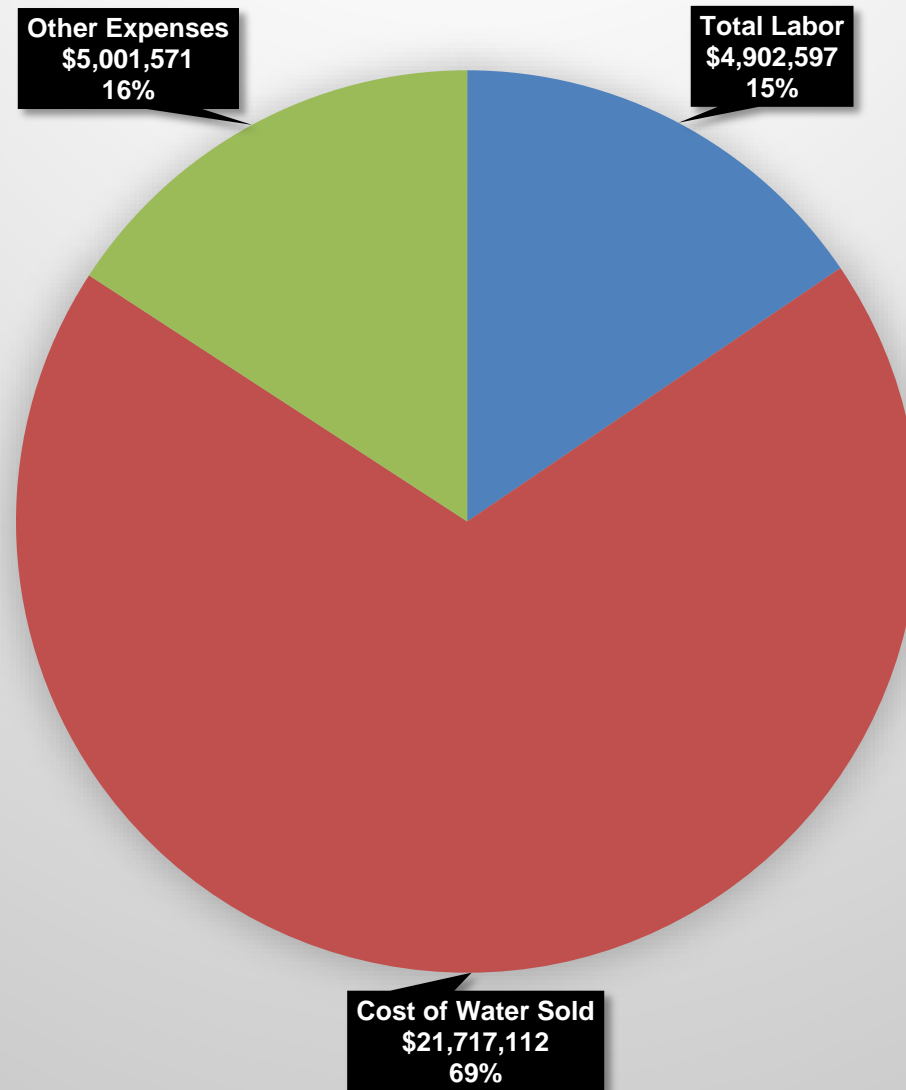

**RAINBOW MUNICIPAL WATER DISTRICT**  
**TREASURER'S MONTHLY REPORT OF INVESTMENTS**  
**PORTFOLIO SUMMARY**  
**3/31/2018**



TYPE	ISSUER	CUSIP	Bond Rating	Date of Maturity	Cost Basis	Market Value	Interest Rate	Yield to Maturity	Next Interest Payment Date	Semi-Annual Interest	Days to Maturity	Fund
Money Market Funds	JP MORGAN MONEY MARKET	48125C068S	N/A		\$ 1,109,204	\$ 1,109,204						
Total Cash & Cash Equivalents					\$ 1,109,204	\$ 1,109,204						
Callable Note	FEDERAL HOME LN MTG CORP	3134G3F96	Aaa	08/28/20	\$ 1,032,851	\$ 996,172	1.660%	1.320%	02/28/18	\$ 8,573	881	53 13108
Callable Note	FEDERAL NATL MTG ASSN	3135GOT45	Aaa	04/05/22	\$ 1,002,910	\$ 973,780	1.875%	1.810%	04/05/18	\$ 9,402	1466	60 13108
Callable Note	FEDERAL FARM CR BKS	3133EHRU9	Aaa	07/19/22	\$ 200,938	\$ 194,058	1.900%	1.800%	01/19/18	\$ 1,909	1571	53 13108
Callable Note	FEDERAL HOME LN MTG CORP	3134GBS94	Aaa	10/26/22	\$ 651,918	\$ 635,609	2.100%	1.800%	04/26/18	\$ 6,845	1670	53 13108
Callable Note	FEDERAL NATL MTG ASSN	3135GOT94	Aaa	01/19/23	\$ 515,226	\$ 513,811	2.375%	2.410%	07/19/18	\$ 6,118	1755	13 13108
Callable Note	FEDERAL NATL MTG ASSN	3135GOT94	Aaa	01/19/23	\$ 480,034	\$ 478,716	2.375%	2.600%	07/19/18	\$ 5,700	1755	53 13108
Callable Note	FEDERAL NATL MTG ASSN	3135GOT94	Aaa	01/19/23	\$ 465,211	\$ 463,932	2.375%	2.600%	07/19/18	\$ 5,524	1755	13 13108
Total Government Obligations					\$ 4,349,087	\$ 4,256,078						
Callable Note	CATERPILLAR FINL CORP	14912HSR2	A2	09/15/21	\$ 1,000,000	\$ 942,160	1.600%	1.600%	03/15/18	\$ 8,000	1264	13 13108
Callable Note	ORACLE CORP	68389XBKO	A1	09/15/21	\$ 1,011,470	\$ 965,460	1.910%	1.900%	03/15/18	\$ 9,660	1264	13 13108
Callable Note	WELLS FARGO	95000U2B8	A2	07/22/22	\$ 989,232	\$ 947,944	2.625%	2.410%	01/22/18	\$ 12,984	1574	13 13108
FDIC Ins. CD	AMERICAN EXPRESS FED SVGS BK	02587CED8	Aaa	07/29/20	\$ 248,000	\$ 245,327	2.360%	2.340%	01/29/18	\$ 2,926	851	60 13108
Callable Note	BARCLAYS BK DEL	06740JKJ4	Aaa	09/16/20	\$ 245,000	\$ 242,993	2.210%	2.200%	03/16/18	\$ 2,707	900	60 13108
FDIC Ins. CD	AMERICAN EXPRESS CENTRN	02587DB64	Aaa	09/23/20	\$ 250,000	\$ 247,093	2.310%	2.300%	03/23/18	\$ 2,888	907	53 13108
FDIC Ins. CD	DISCOVER BANK	254672F29	N/A	08/10/21	\$ 248,000	\$ 238,618	1.500%	1.500%	02/10/18	\$ 1,860	1228	53 13108
FDIC Ins. CD	WELLS FARGO BANK NATL ASSN	949763AF3	N/A	08/17/21	\$ 98,000	\$ 94,113	1.550%	1.550%	02/17/18	\$ 760	1235	53 13108
FDIC Ins. CD	WELLS FARGO BANK NATL ASSN	949763AF3	N/A	08/17/21	\$ 150,000	\$ 144,051	1.550%	1.550%	02/17/18	\$ 1,163	1235	13 13108
FDIC Ins. CD	STATE BK INDIA NEW YORK NY	8562846U3	Aaa	03/14/22	\$ 250,000	\$ 245,543	2.250%	2.250%	03/14/18	\$ 2,813	1444	13 13108
FDIC Ins. CD	SALLIE MAE BK SLT LAKE CITY	79540ZW8	Aaa	03/22/22	\$ 250,000	\$ 246,443	2.340%	2.340%	03/22/18	\$ 2,925	1452	60 13108
FDIC Ins. CD	SYNCHRONY BK RETAIL	87165EMKO	N/A	05/26/22	\$ 240,000	\$ 236,707	2.400%	2.400%	05/26/18	\$ 2,880	1517	53 13108
FDIC Ins. CD	GOLDMAN SACHS BK USA NY	38148PKT3	N/A	06/14/22	\$ 245,000	\$ 241,048	2.350%	2.350%	12/14/18	\$ 2,879	1536	53 13108
FDIC Ins. CD	CAPITAL ONE NATL ASSN VA	14042RKL4	N/A	11/22/22	\$ 250,000	\$ 245,498	2.400%	2.400%	05/22/18	\$ 3,000	1697	53 13108
FDIC Ins. CD	MORGAN STANLEY	61747MF634	N/A	01/11/23	\$ 246,000	\$ 243,988	2.650%	2.650%	07/11/18	\$ 3,260	1747	53 13108
FDIC Ins. CD	BMW BANK NORTH AMER	05580AMB7	N/A	03/29/23	\$ 240,000	\$ 240,434	2.900%	2.900%	09/29/18	\$ 3,480	1824	53 13108
Total Corporate Obligations					\$ 5,960,702	\$ 5,767,419						
Callable Note	AUSTRALIA & NEW ZEALA BKG	05253JAM3	Aa2	06/01/21	\$ 517,228	\$ 487,555	2.300%	1.550%	12/01/17	\$ 5,948	1158	53 13108
Callable Note	NATIONAL AUSTRALIA BK NY	63254AAR9	Aa2	07/12/21	\$ 508,870	\$ 480,265	1.875%	1.880%	01/12/18	\$ 4,771	1199	53 13108
Callable Note	BANK OF MONTREAL	06367TJX90	Aa3	08/27/21	\$ 1,011,840	\$ 960,470	1.900%	1.900%	02/27/18	\$ 9,612	1245	60 13108
Total Non-US Securities					\$ 2,037,938	\$ 1,928,290						
Subtotal Long Term					\$ 13,456,930	\$ 13,060,991						
Pooled Investment	Local Agency Investment Fund (LAIF)				\$ 7,584,576	\$ 7,584,576	1.172%					
Portfolio Totals					<b>\$ 21,041,506</b>	<b>\$ 20,645,567</b>						

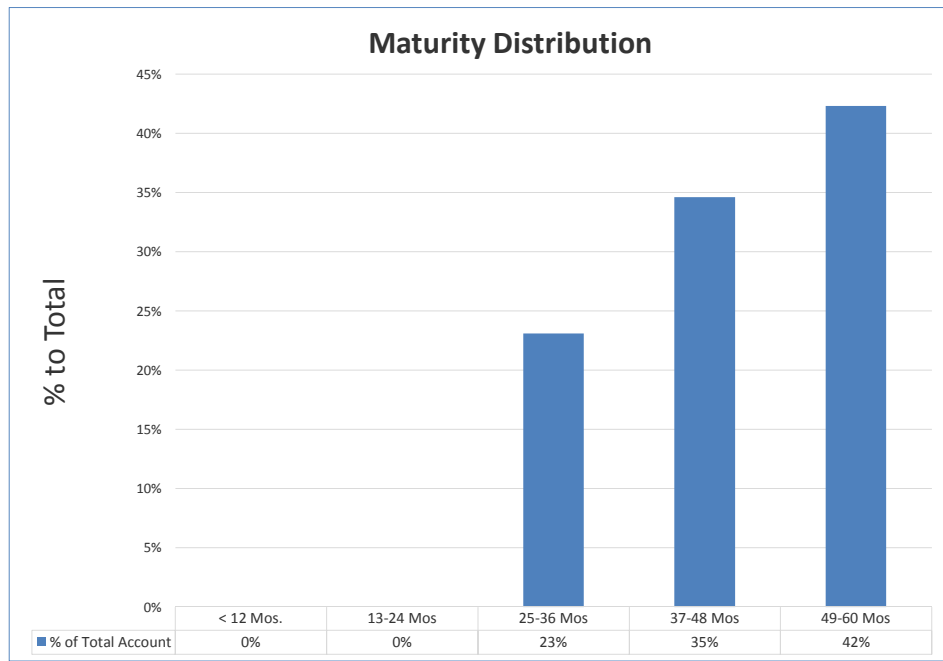
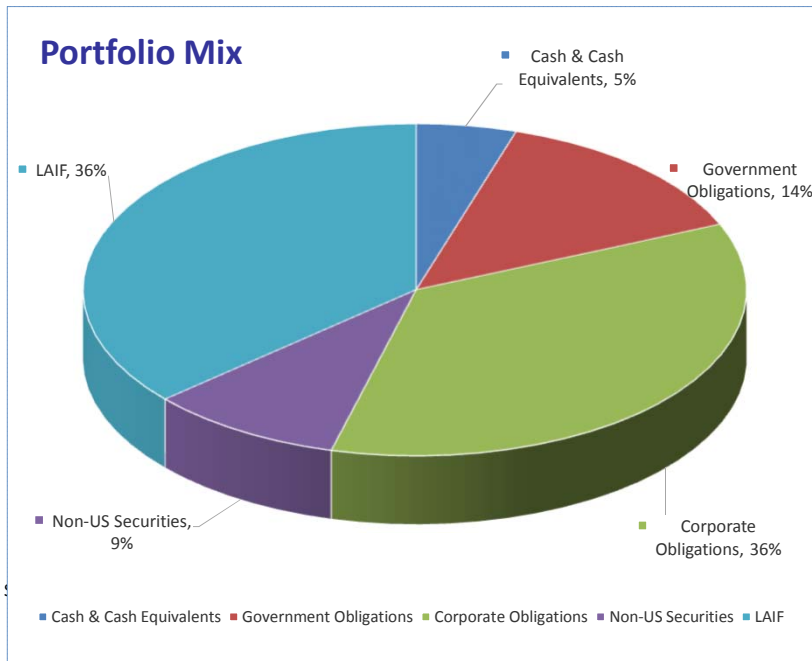

This monthly report accurately reflects all District pooled investments. It is in conformity with the Investment Administrative code section 5.03.080. The District has sufficient cash flow to meet six months of obligations. This is in effect is in compliance with the current Investment Policy.

5/8/2018

Vanessa Martinez, Treasurer

Accounts Payable  
 March American Express



Check Number	Check Date		Amount
<b>245 - ABCANA INDUSTRIES Line Item Account</b>			
4121801	04/12/2018		
Inv	1020528		
	<u>Line Item Date</u>	<u>Line Item Description</u>	<u>Line Item Account</u>
	02/09/2018	UN1791 HYPOCHLORITE SOLUTION 12.5% 8PG III	01-32-72000 747.49
	Inv 1020528 Total		747.49
Inv	1021228		
	<u>Line Item Date</u>	<u>Line Item Description</u>	<u>Line Item Account</u>
	02/28/2018	UN1791 HYPOCHLORITE SOLUTION 12.5% 8PG III	01-32-72000 1,195.98
	Inv 1021228 Total		1,195.98
4121801 Total:			1,943.47
<b>245 - ABCANA INDUSTRIES Total:</b>			1,943.47
<b>310 - ACWA Line Item Account</b>			
4121802	04/12/2018		
Inv	INV18476-R9T5L5		
	<u>Line Item Date</u>	<u>Line Item Description</u>	<u>Line Item Account</u>
	03/01/2018	2018 ACWA SPRING CONFERENCE - MMACK	03-20-75300 699.00
	Inv INV18476-R9T5L5 Total		699.00
4121802 Total:			699.00
<b>310 - ACWA Total:</b>			699.00
<b>603308 - ALASKA AIRLINES Line Item Account</b>			
4121803	04/12/2018		
Inv	DXSDOL		
	<u>Line Item Date</u>	<u>Line Item Description</u>	<u>Line Item Account</u>
	03/14/2018	CONFERENCES AND TRAINING- KHARP	03-43-75300 363.60
	Inv DXSDOL Total		363.60
4121803 Total:			363.60

**603308 - ALASKA AIRLINES Total:** 363.60

**280 - AMAZON.COM Line Item Account**

4121804 04/12/2018

Inv 2679373-1640250

<u>Line Item Date</u>	<u>Line Item Description</u>	<u>Line Item Account</u>	
03/09/2018	MONEY TREE	03-41-56513	10.99

Inv 2679373-1640250 Total 10.99

Inv 3608324-3423429

<u>Line Item Date</u>	<u>Line Item Description</u>	<u>Line Item Account</u>	
03/20/2018	APC 1500VA Compact UPS Battery Backup & Surge Protectc	03-41-60100	192.29

Inv 3608324-3423429 Total 192.29

Inv 4539704-8571432

<u>Line Item Date</u>	<u>Line Item Description</u>	<u>Line Item Account</u>	
03/28/2018	Monoprice 18-Inch SATA III 6.0 Gbps Cable with Locking La	03-41-60100	8.23
03/28/2018	Corsair Dual SSD Mounting Bracket 3.5" CSSD-BRKT2	03-41-60100	15.09

Inv 4539704-8571432 Total 23.32

Inv 5869815-5405846

<u>Line Item Date</u>	<u>Line Item Description</u>	<u>Line Item Account</u>	
03/16/2018	HEADSET	03-52-72000	21.32

Inv 5869815-5405846 Total 21.32

Inv 6542781-0145827

<u>Line Item Date</u>	<u>Line Item Description</u>	<u>Line Item Account</u>	
03/22/2018	DUAL MONITOR STAND FOR AHMED AND DARREN'S	03-41-60100	409.42

Inv 6542781-0145827 Total 409.42

Inv 6557662-5429027

<u>Line Item Date</u>	<u>Line Item Description</u>	<u>Line Item Account</u>	
03/28/2018	SSD Drives for Ahmed and Tom's Computers	03-41-60100	275.50

Inv 6557662-5429027 Total 275.50

Inv 6995892-3941000

<u>Line Item Date</u>	<u>Line Item Description</u>	<u>Line Item Account</u>	
02/22/2018	Box of blue pens	01-32-72000	23.68
02/22/2018	Laptop back pack	01-32-72000	110.92
02/22/2018	Aluminum form holder	01-32-72000	23.69

Inv 6995892-3941000 Total 158.29



Inv	8576972-5790613				
	<u>Line Item Date</u>	<u>Line Item Description</u>	<u>Line Item Account</u>		
	03/16/2018	TELEPHONE ADAPTER	03-52-72000	11.49	
	Inv 8576972-5790613 Total				11.49
Inv	9502947-7157004				
	<u>Line Item Date</u>	<u>Line Item Description</u>	<u>Line Item Account</u>		
	03/28/2018	Video Card for Tom's Computer	03-41-60100	253.34	
	Inv 9502947-7157004 Total				253.34
4121804 Total:					1,355.96
<b>280 - AMAZON.COM Total:</b>					1,355.96
<b>603481 - AMERICAN PUBLIC WORKS ASSOCIATION Line Item Account</b>					
4121805	04/12/2018				
Inv	030518				
	<u>Line Item Date</u>	<u>Line Item Description</u>	<u>Line Item Account</u>		
	03/05/2018	US INDIVIDUAL MEMBERSHIP	03-42-72400	123.00	
	Inv 030518 Total				123.00
Inv	16257				
	<u>Line Item Date</u>	<u>Line Item Description</u>	<u>Line Item Account</u>		
	03/05/2018	JOB POSTING-DISTRICT ENGINEER	03-42-72400	485.00	
	Inv 16257 Total				485.00
4121805 Total:					608.00
<b>603481 - AMERICAN PUBLIC WORKS ASSOCIATION Total:</b>					608.00
<b>220 - APPLE, INC Line Item Account</b>					
4121806	04/12/2018				
Inv	W605404901				
	<u>Line Item Date</u>	<u>Line Item Description</u>	<u>Line Item Account</u>		
	03/26/2018	15-inch MacBook Pro - Space Gray - Touch Bar and Touch ID	03-41-60100	2,832.41	
	Inv W605404901 Total				2,832.41
Inv	W605404901 (2)				
	<u>Line Item Date</u>	<u>Line Item Description</u>	<u>Line Item Account</u>		
	03/26/2018	USB-C to Lightning Cable (1 m)	03-41-60100	27.19	
	Inv W605404901 (2) Total				27.19

Inv	W605404901 (3)			
	<u>Line Item Date</u>	<u>Line Item Description</u>	<u>Line Item Account</u>	
	03/26/2018	USB-C to USB Adapter	03-41-60100	20.66
	03/26/2018	Moshi USB-C to DisplayPort Cable	03-41-60100	108.64
	Inv W605404901 (3) Total			129.30
4121806 Total:				2,988.90
<b>220 - APPLE, INC Total:</b>				2,988.90
<b>603346 - BEST BUY Line Item Account</b>				
4121807	04/12/2018			
Inv	805535827760			
	<u>Line Item Date</u>	<u>Line Item Description</u>	<u>Line Item Account</u>	
	03/19/2018	OtterBox - Defender Series Case for Apple® iPhone® 6 Plus a	03-41-60100	30.26
	Inv 805535827760 Total			30.26
4121807 Total:				30.26
<b>603346 - BEST BUY Total:</b>				30.26
<b>603474 - BOXWOOD TECHNOLOGY Line Item Account</b>				
4121808	04/12/2018			
Inv	3171915			
	<u>Line Item Date</u>	<u>Line Item Description</u>	<u>Line Item Account</u>	
	03/05/2018	JOB POSTING- ENGINEERING MANAGER	03-42-75500	545.00
	Inv 3171915 Total			545.00
4121808 Total:				545.00
<b>603474 - BOXWOOD TECHNOLOGY Total:</b>				545.00
<b>4970 - BRADY SAND &amp; MATERIAL, INC. Line Item Account</b>				
4121809	04/12/2018			
Inv	201802-23			
	<u>Line Item Date</u>	<u>Line Item Description</u>	<u>Line Item Account</u>	
	02/12/2018	CLASS II, THE YARD FTBILL 72950 & 72956	01-34-72000	1,165.14
	Inv 201802-23 Total			1,165.14
Inv	201802-30			
	<u>Line Item Date</u>	<u>Line Item Description</u>	<u>Line Item Account</u>	
	02/28/2018	CLASS II, THE YARD FTBILL 72967	01-34-72000	616.56
	Inv 201802-30 Total			616.56

Inv	201802-31				
	<u>Line Item Date</u>	<u>Line Item Description</u>	<u>Line Item Account</u>		
	02/28/2018	CLASS II, THE YARD FTBILL 72968 & 72969	01-34-72000	1,180.61	
	Inv 201802-31 Total				1,180.61
4121809 Total:				2,962.31	
<b>4970 - BRADY SAND &amp; MATERIAL, INC. Total:</b>				2,962.31	
<b>603218 - BROWN &amp; CALDWELL, BC WATER Line Item Account</b>					
4121810	04/12/2018				
Inv	237830				
	<u>Line Item Date</u>	<u>Line Item Description</u>	<u>Line Item Account</u>		
	03/12/2018	RECRUITMENT SERVICES DUES	03-43-72400	200.00	
	Inv 237830 Total				200.00
4121810 Total:				200.00	
<b>603218 - BROWN &amp; CALDWELL, BC WATER Total:</b>				200.00	
<b>603475 - BUYSHADE.COM Line Item Account</b>					
4121811	04/12/2018				
Inv	91529				
	<u>Line Item Date</u>	<u>Line Item Description</u>	<u>Line Item Account</u>		
	03/26/2018	SIDEWALL IMPRINT, LOGO, FRAME	03-41-56513	1,256.20	
	Inv 91529 Total				1,256.20
4121811 Total:				1,256.20	
<b>603475 - BUYSHADE.COM Total:</b>				1,256.20	
<b>1965 - CALIFORNIA SPECIAL DISTRICTS ASSOCIATION Line Item Account</b>					
4121812	04/12/2018				
Inv	42448				
	<u>Line Item Date</u>	<u>Line Item Description</u>	<u>Line Item Account</u>		
	03/01/2018	AB1825 TRAINING - BSTEWART (REFUND)	03-20-75300	-25.00	
	Inv 42448 Total				-25.00
Inv	66471				
	<u>Line Item Date</u>	<u>Line Item Description</u>	<u>Line Item Account</u>		
	03/01/2018	AB1825 TRAINING - BSTEWART	03-20-75300	25.00	

Inv 66471 Total				25.00
Inv 67192				
	<u>Line Item Date</u>	<u>Line Item Description</u>	<u>Line Item Account</u>	
	03/28/2018	2018 SPECIAL DISTRICT LEGISLATIVE DAYS REGISTR	03-20-75300	275.00
	03/28/2018	2018 SPECIAL DISTRICT LEGISLATIVE DAYS REGISTR	03-20-75300	275.00
	03/28/2018	2018 SPECIAL DISTRICT LEGISLATIVE DAYS REGISTR	03-41-75300	275.00
Inv 67192 Total				825.00
4121812 Total:				825.00
<b>1965 - CALIFORNIA SPECIAL DISTRICTS ASSOCIATION Total:</b>				825.00
<b>2885 - CORELOGIC INFORMATION Line Item Account</b>				
4121813	04/12/2018			
Inv 81873490				
	<u>Line Item Date</u>	<u>Line Item Description</u>	<u>Line Item Account</u>	
	02/28/2018	REALQUEST.COM GEOGRAPHIC PACKAGE	03-91-63102	192.50
Inv 81873490 Total				192.50
Inv 81873633				
	<u>Line Item Date</u>	<u>Line Item Description</u>	<u>Line Item Account</u>	
	02/28/2018	REALQUEST.COM SALE DOC	03-91-63102	10.00
Inv 81873633 Total				10.00
4121813 Total:				202.50
<b>2885 - CORELOGIC INFORMATION Total:</b>				202.50
<b>2027 - CULLIGAN OF ESCONDIDO Line Item Account</b>				
4121814	04/12/2018			
Inv 022818				
	<u>Line Item Date</u>	<u>Line Item Description</u>	<u>Line Item Account</u>	
	02/28/2018	WATER SOFTNER, SERVICE PERIOD 03/01-03/31	03-41-63401	70.78
Inv 022818 Total				70.78
4121814 Total:				70.78
<b>2027 - CULLIGAN OF ESCONDIDO Total:</b>				70.78
<b>603482 - CUSTOMINK.COM Line Item Account</b>				
4121815	04/12/2018			

Inv	19521526				
	<u>Line Item Date</u>	<u>Line Item Description</u>	<u>Line Item Account</u>		
	03/26/2018	EMPLOYEE POLO SHIRTS W/ CUSTOM LOGO	03-41-56513	563.67	
	Inv 19521526 Total				563.67
4121815 Total:					563.67
<b>603482 - CUSTOMINK.COM Total:</b>					563.67
<b>603477 - DOTSTER.COM Line Item Account</b>					
4121816	04/12/2018				
Inv	166352983				
	<u>Line Item Date</u>	<u>Line Item Description</u>	<u>Line Item Account</u>		
	03/06/2018	2-YEAR SUBSCRIPTION	03-41-72400	34.98	
	Inv 166352983 Total				34.98
4121816 Total:					34.98
<b>603477 - DOTSTER.COM Total:</b>					34.98
<b>603473 - FACEBOOK Line Item Account</b>					
4121817	04/12/2018				
Inv	3287707				
	<u>Line Item Date</u>	<u>Line Item Description</u>	<u>Line Item Account</u>		
	02/03/2018	FACEBOOK ADS- JOB POSTING	03-42-75500	25.00	
	Inv 3287707 Total				25.00
Inv	3325180				
	<u>Line Item Date</u>	<u>Line Item Description</u>	<u>Line Item Account</u>		
	03/18/2018	FACEBOOK ADS- JOB POSTING	03-42-75500	31.54	
	Inv 3325180 Total				31.54
Inv	3325181				
	<u>Line Item Date</u>	<u>Line Item Description</u>	<u>Line Item Account</u>		
	03/18/2018	FACEBOOK ADS- JOB POSTING	03-42-75500	18.46	
	Inv 3325181 Total				18.46
Inv	3326764				
	<u>Line Item Date</u>	<u>Line Item Description</u>	<u>Line Item Account</u>		
	03/19/2018	FACEBOOK ADS- JOB POSTING	03-42-75500	2.17	
	Inv 3326764 Total				2.17

Inv	3326765			
	<u>Line Item Date</u>	<u>Line Item Description</u>	<u>Line Item Account</u>	
	03/19/2018	FACEBOOK ADS- JOB POSTING	03-42-75500	1.54
	Inv 3326765 Total			1.54
4121817 Total:				78.71
<b>603473 - FACEBOOK Total:</b>				78.71
<b>3325 - GRAINGER, W.W. INC. Line Item Account</b>				
4121818	04/12/2018			
Inv	9700906523			
	<u>Line Item Date</u>	<u>Line Item Description</u>	<u>Line Item Account</u>	
	02/15/2018	Striking wrench 1-1/8"	01-33-72000	111.93
	02/15/2018	SAFETY YELLOW SPRAY PAINT	01-00-14610	217.22
	02/15/2018	Item # 2ZZG4 Flexible Cylinder Hone Bore Dia. 4 In. 180 Grit	03-36-73000	79.97
	02/15/2018	BLACK MARKING PAINT	01-00-14610	97.95
	02/15/2018	BLUE MARKING PAINT	01-00-14610	102.15
	02/15/2018	PURPLE MARKING PAINT	01-00-14610	20.94
	02/15/2018	Item # 2ZYX6 Flexible Cylinder Hone Bore Dia. 2 In. Abrasi	03-36-73000	26.99
	02/15/2018	Item # 2 ZPJ9 Engine Cylinder Hone Adjustable from 2" - 7"	03-36-73000	39.80
	Inv 9700906523 Total			696.95
Inv	9720623934			
	<u>Line Item Date</u>	<u>Line Item Description</u>	<u>Line Item Account</u>	
	03/07/2018	HACK SAW BLADES	01-00-14610	68.96
	03/07/2018	TEFLON PIPE DOPE 1/2 PINT	01-00-14610	58.32
	03/07/2018	MASKING TAPE	01-00-14610	51.01
	03/07/2018	PRIMER CLEANER PURPLE 8OZ	01-00-14610	17.07
	03/07/2018	ROUND SHOVEL	01-00-14610	42.74
	Inv 9720623934 Total			238.10
Inv	9720623942			
	<u>Line Item Date</u>	<u>Line Item Description</u>	<u>Line Item Account</u>	
	03/07/2018	SAFETY YELLOW SPRAY PAINT	01-00-14610	86.89
	Inv 9720623942 Total			86.89
Inv	9724873097			
	<u>Line Item Date</u>	<u>Line Item Description</u>	<u>Line Item Account</u>	
	03/12/2018	1" CHIP CHINA HAIR PAINT BRUSH	01-00-14610	20.94
	Inv 9724873097 Total			20.94
Inv	9732473427			
	<u>Line Item Date</u>	<u>Line Item Description</u>	<u>Line Item Account</u>	
	03/19/2018	Screwdriver set, 6pc no. 10J319	01-32-73000	69.00
	03/19/2018	4FZZ7 Extension cord, 20A, 10/3 ga., 50ft	01-32-73000	116.44

03/19/2018	52YX11 Impact wrench, 18v, 1/2"	01-32-73000	462.80
03/19/2018	30F063 Case, 13-1/2 in Lx10-1/8 Wx3, Black	01-32-73000	22.80
03/19/2018	4ORC5 Impact socket set 1/2" Dr.	01-32-73000	310.13
03/19/2018	2A527 Rip Hammer, fiberglass, 20oz	01-32-73000	27.38
03/19/2018	34E641 Striaight bucket, 150lb, Canvas	01-32-73000	132.44
Inv 9732473427 Total			1,140.99

4121818 Total: 2,183.87

**3325 - GRAINGER, W.W. INC. Total:** 2,183.87

**603478 - HOTELS.COM Line Item Account**

4121819	04/12/2018		
Inv	146515602276		
<u>Line Item Date</u>	<u>Line Item Description</u>	<u>Line Item Account</u>	
03/22/2018	6/4-6/7/17 CONFERENCE ROOM STAY-AKHATTAB	03-41-75300	823.95
Inv 146515602276 Total			823.95

4121819 Total: 823.95

**603478 - HOTELS.COM Total:** 823.95

**603476 - INFOR TECHED Line Item Account**

4121820	04/12/2018		
Inv	107999273		
<u>Line Item Date</u>	<u>Line Item Description</u>	<u>Line Item Account</u>	
03/22/2018	INFOR CONFERENCE-AKHATTAB	03-41-75300	1,599.00
Inv 107999273 Total			1,599.00

4121820 Total: 1,599.00

**603476 - INFOR TECHED Total:** 1,599.00

**603431 - LINKEDIN CORPORATION Line Item Account**

4121821	04/12/2018		
Inv	2955907936		
<u>Line Item Date</u>	<u>Line Item Description</u>	<u>Line Item Account</u>	
03/02/2018	JOB POSTING-DISTRICT ENGINEER	03-42-75500	85.97
Inv 2955907936 Total			85.97

Inv 2956062726

<u>Line Item Date</u>	<u>Line Item Description</u>	<u>Line Item Account</u>	
03/01/2018	JOB POSTING- RIGHT-OF-WAY AND FACILITIES COOR	03-42-75500	255.50

	Inv 2956062726 Total			255.50
Inv	2979884716			
	<u>Line Item Date</u>	<u>Line Item Description</u>	<u>Line Item Account</u>	
	03/14/2018	JOB POSTING- SAFETY OFFICER	03-42-75500	20.40
	Inv 2979884716 Total			20.40
Inv	2991898666			
	<u>Line Item Date</u>	<u>Line Item Description</u>	<u>Line Item Account</u>	
	03/20/2018	JOB POSTING- SAFETY OFFICER	03-42-75500	85.10
	Inv 2991898666 Total			85.10
Inv	3002703726			
	<u>Line Item Date</u>	<u>Line Item Description</u>	<u>Line Item Account</u>	
	03/26/2018	JOB POSTING-SAFETY OFFICER	03-42-75500	40.40
	Inv 3002703726 Total			40.40
Inv	3930769403			
	<u>Line Item Date</u>	<u>Line Item Description</u>	<u>Line Item Account</u>	
	03/02/2018	REFUND FOR ORDER 2956062726	03-42-75500	-127.40
	Inv 3930769403 Total			-127.40
Inv	648897626			
	<u>Line Item Date</u>	<u>Line Item Description</u>	<u>Line Item Account</u>	
	03/02/2018	JOB POSTING- RIGHT-OF-WAY AND FACILITIES COOR	03-42-75500	2.80
	Inv 648897626 Total			2.80
	4121821 Total:			362.77
	<b>603431 - LINKEDIN CORPORATION Total:</b>			362.77
	<b>5310 - NATIONAL NOTARY ASSOCIATION Line Item Account</b>			
	4121822	04/12/2018		
Inv	5674726			
	<u>Line Item Date</u>	<u>Line Item Description</u>	<u>Line Item Account</u>	
	03/05/2018	RENEW PACKAGE, 4 YEAR MEMBERSHIP, SOFTCOVEI	03-41-72400	722.90
	Inv 5674726 Total			722.90
	4121822 Total:			722.90
	<b>5310 - NATIONAL NOTARY ASSOCIATION Total:</b>			722.90
	<b>603404 - NATUREBOX Line Item Account</b>			



4121823	04/12/2018			
Inv	00151507			
	<u>Line Item Date</u>	<u>Line Item Description</u>	<u>Line Item Account</u>	
	03/17/2018	EMPLOYEE SNACKS, BOX UNLIMITED	03-41-56513	750.00
	Inv 00151507 Total			750.00

4121823 Total: 750.00

**603404 - NATUREBOX Total:** 750.00

**5286 - NOSSAMAN, LLP Line Item Account**

4121824	04/12/2018			
Inv	475679			
	<u>Line Item Date</u>	<u>Line Item Description</u>	<u>Line Item Account</u>	
	01/24/2018	GENERAL COUNSEL SERVICES THROUGH 12/31/17	03-91-70000	248.50
	01/24/2018	GENERAL COUNSEL SERVICES THROUGH 12/31/17	60-00-11168	284.00
	01/24/2018	GENERAL COUNSEL SERVICES THROUGH 12/31/17	03-41-70300	4,260.00
	Inv 475679 Total			4,792.50

Inv	477712			
	<u>Line Item Date</u>	<u>Line Item Description</u>	<u>Line Item Account</u>	
	02/26/2018	GENERAL COUNSEL SERVICES THROUGH 1/31/18	03-91-70000	602.50
	02/26/2018	GENERAL COUNSEL SERVICES THROUGH 1/31/18	26-00-11122	1,597.50
	02/26/2018	GENERAL COUNSEL SERVICES THROUGH 1/31/18	03-41-70300	9,905.50
	02/26/2018	GENERAL COUNSEL SERVICES THROUGH 1/31/18	60-00-11168	319.50
	Inv 477712 Total			12,425.00

Inv	477713			
	<u>Line Item Date</u>	<u>Line Item Description</u>	<u>Line Item Account</u>	
	02/26/2018	GENERAL COUNSEL SERVICES THROUGH 1/31/18	03-41-70300	1,430.00
	02/26/2018	GENERAL COUNSEL SERVICES THROUGH 1/31/18	26-00-11122	130.00
	Inv 477713 Total			1,560.00

4121824 Total: 18,777.50

**5286 - NOSSAMAN, LLP Total:** 18,777.50

**5425 - OFFICE DEPOT Line Item Account**

4121825	04/12/2018			
Inv	107301977001			
	<u>Line Item Date</u>	<u>Line Item Description</u>	<u>Line Item Account</u>	
	02/13/2018	INK TONER - YELLOW	03-91-72000	91.27
	02/13/2018	INK TONER - MAGENTA	03-91-72000	91.26
	02/13/2018	LETTER-SIZE WALL FILES	03-91-72000	20.16
	02/13/2018	NK TONER - CYAN	03-91-72000	91.26

	Inv 107301977001 Total			293.95
Inv	107622697001			
	<u>Line Item Date</u>	<u>Line Item Description</u>	<u>Line Item Account</u>	
	02/14/2018	FILE, STORAGE	03-41-72000	58.72
	Inv 107622697001 Total			58.72
Inv	111296947-001			
	<u>Line Item Date</u>	<u>Line Item Description</u>	<u>Line Item Account</u>	
	02/26/2018	Log Books	02-61-72000	215.41
	Inv 111296947-001 Total			215.41
Inv	111525543-001			
	<u>Line Item Date</u>	<u>Line Item Description</u>	<u>Line Item Account</u>	
	02/28/2018	MESH ORGANIZER, BLACK	03-41-72900	32.09
	Inv 111525543-001 Total			32.09
Inv	111527974-001			
	<u>Line Item Date</u>	<u>Line Item Description</u>	<u>Line Item Account</u>	
	02/27/2018	Xerox 008R13061 Waste Toner Bottle	01-00-14610	140.32
	02/27/2018	Xerox 008R12941 Staple Cartridges	01-00-14610	161.62
	Inv 111527974-001 Total			301.94
Inv	112611302-001			
	<u>Line Item Date</u>	<u>Line Item Description</u>	<u>Line Item Account</u>	
	02/27/2018	RETURNED ITEMS-ORGANIZER, WALL FILE	03-41-72900	-32.09
	Inv 112611302-001 Total			-32.09
Inv	112611373-001			
	<u>Line Item Date</u>	<u>Line Item Description</u>	<u>Line Item Account</u>	
	03/02/2018	Log Books	02-61-72000	-53.85
	Inv 112611373-001 Total			-53.85
Inv	113640134-001			
	<u>Line Item Date</u>	<u>Line Item Description</u>	<u>Line Item Account</u>	
	03/06/2018	SINGLE WALL POCKETS, LETTER SIZE, BLACK, 3-PAC	03-41-72900	25.63
	03/06/2018	Log Books	02-61-72000	53.85
	03/06/2018	MESH ORGANIZER, BLACK (ITEM #314934)	03-41-72900	6.46
	Inv 113640134-001 Total			85.94
Inv	113874766001			
	<u>Line Item Date</u>	<u>Line Item Description</u>	<u>Line Item Account</u>	
	03/07/2018	#389723 NAVY LINEN PRESENTATION COVERS	01-41-72000	53.87
	03/07/2018	#531824 CLEAR BINDING COVERS	01-41-72000	32.31

	Inv 113874766001 Total			86.18
Inv	115399816001			
	<u>Line Item Date</u>	<u>Line Item Description</u>	<u>Line Item Account</u>	
	03/14/2018	ACCU-STAMP2, PRE-INK MESSAGE STAMP, "POSTED",	03-41-72900	11.30
	03/14/2018	OFFICE DEPOT BRAND, GRN HANGING FOLDERS, LEC	03-41-72900	18.39
	03/14/2018	OFFICE DEPOT BRAND, HANGING FOLDER TABS, 3 1/2	03-41-72900	8.28
	Inv 115399816001 Total			37.97
Inv	115400662001			
	<u>Line Item Date</u>	<u>Line Item Description</u>	<u>Line Item Account</u>	
	03/14/2018	ACCU-STAMP2, SHUTTER ONE-COLOR STAMP, "COMF	03-41-72900	8.29
	Inv 115400662001 Total			8.29
Inv	115422968001			
	<u>Line Item Date</u>	<u>Line Item Description</u>	<u>Line Item Account</u>	
	03/14/2018	MONTHLY DESK PAD CALENDAR, 17" X 22", BLACK, (	03-41-72900	19.60
	Inv 115422968001 Total			19.60
Inv	115423271001			
	<u>Line Item Date</u>	<u>Line Item Description</u>	<u>Line Item Account</u>	
	03/13/2018	MONTHLY DESK PAD CALENDAR, 17" X 22" (ITEM #74	03-41-72900	17.22
	Inv 115423271001 Total			17.22
	4121825 Total:			1,071.37
	<b>5425 - OFFICE DEPOT Total:</b>			1,071.37
	<b>5910 - PACIFIC PIPELINE SUPPLY Line Item Account</b>			
	4121826	04/12/2018		
Inv	319854			
	<u>Line Item Date</u>	<u>Line Item Description</u>	<u>Line Item Account</u>	
	01/30/2018	6-8" 150# T316 SS FLG BOLT KIT	01-00-14610	637.88
	Inv 319854 Total			637.88
Inv	320126			
	<u>Line Item Date</u>	<u>Line Item Description</u>	<u>Line Item Account</u>	
	02/12/2018	RESIDENTIAL FIRE HYDRANT	01-00-14610	5,933.45
	Inv 320126 Total			5,933.45
Inv	320186			
	<u>Line Item Date</u>	<u>Line Item Description</u>	<u>Line Item Account</u>	
	02/12/2018	4" 150# WELD FLANGE	01-00-14610	285.11
	02/12/2018	4" 150# FLANGED DUCTILE 90	01-00-14610	314.63

	02/12/2018	4" 150# T316 SS FLG BOLT KIT	01-00-14610	290.92
	Inv 320186 Total			890.66
Inv	320222			
	<u>Line Item Date</u>	<u>Line Item Description</u>	<u>Line Item Account</u>	
	02/16/2018	4" 300# T316 SS FLG BOLT KIT	01-00-14610	517.20
	02/16/2018	6" 300# T316 SS FLG BOLT KIT	01-00-14610	694.99
	Inv 320222 Total			1,212.19
Inv	320417			
	<u>Line Item Date</u>	<u>Line Item Description</u>	<u>Line Item Account</u>	
	02/22/2018	2" BRASS PIPE	01-00-14610	3,883.31
	02/22/2018	2" BRASS 90	01-00-14610	804.25
	02/22/2018	1/2" Teflon Tape	01-00-14610	42.56
	02/22/2018	3/4" Teflon Tape	01-00-14610	71.11
	Inv 320417 Total			4,801.23
Inv	320418			
	<u>Line Item Date</u>	<u>Line Item Description</u>	<u>Line Item Account</u>	
	02/22/2018	6" #38 DRESSER COUPLING	01-00-14610	345.66
	Inv 320418 Total			345.66
4121826 Total:				13,821.07
<b>5910 - PACIFIC PIPELINE SUPPLY Total:</b>				13,821.07
<b>603187 - PERRAULT CORPORATION Line Item Account</b>				
4121827	04/12/2018			
Inv	98605			
	<u>Line Item Date</u>	<u>Line Item Description</u>	<u>Line Item Account</u>	
	02/01/2018	1" MINUS	01-34-72000	117.75
	Inv 98605 Total			117.75
Inv	98610			
	<u>Line Item Date</u>	<u>Line Item Description</u>	<u>Line Item Account</u>	
	01/24/2018	1" MINUS	01-34-72000	301.31
	Inv 98610 Total			301.31
Inv	98628			
	<u>Line Item Date</u>	<u>Line Item Description</u>	<u>Line Item Account</u>	
	02/05/2018	1" MINUS	01-34-72000	250.00
	Inv 98628 Total			250.00

Inv	98682			
	<u>Line Item Date</u>	<u>Line Item Description</u>	<u>Line Item Account</u>	
	02/06/2018	1" MINUS	01-34-72000	412.13
	Inv 98682 Total			412.13
Inv	98683			
	<u>Line Item Date</u>	<u>Line Item Description</u>	<u>Line Item Account</u>	
	02/07/2018	CLASS II BASE, 1" MINUS	01-34-72000	1,012.66
	Inv 98683 Total			1,012.66
Inv	98701			
	<u>Line Item Date</u>	<u>Line Item Description</u>	<u>Line Item Account</u>	
	02/08/2018	CLASS II BASE, 1" MINUS	01-34-72000	483.93
	Inv 98701 Total			483.93
Inv	98702			
	<u>Line Item Date</u>	<u>Line Item Description</u>	<u>Line Item Account</u>	
	02/09/2018	1" MINUS	01-34-72000	1,059.75
	Inv 98702 Total			1,059.75
Inv	98872			
	<u>Line Item Date</u>	<u>Line Item Description</u>	<u>Line Item Account</u>	
	02/20/2018	CLASS II BASE	01-34-72000	525.89
	Inv 98872 Total			525.89

4121827 Total: 4,163.42

**603187 - PERRAULT CORPORATION Total:** 4,163.42

**603118 - POWELL'S OFFICE FURNITURE Line Item Account**

4121828 04/12/2018

Inv	9584			
	<u>Line Item Date</u>	<u>Line Item Description</u>	<u>Line Item Account</u>	
	03/08/2018	Desk 66"x30", 48" return, two sets of drawers	03-41-63401	641.63
	03/08/2018	Cubicle Partition Foot	03-41-63401	29.36
	03/08/2018	Desk 66"x30", 42" return, two sets of drawers	03-41-63401	641.63
	03/08/2018	Lateral Files	03-41-63401	386.06
	03/08/2018	Cubicle Partition	03-41-63401	233.81
	03/08/2018	Desk 66"x30"	03-41-63401	228.38
	03/08/2018	Desk 6'x3', 4' return, two sets of drawers	03-41-63401	760.16
	Inv 9584 Total			2,921.03

4121828 Total: 2,921.03

**603118 - POWELL'S OFFICE FURNITURE Total:** 2,921.03

**603480 - POWER SYSTEMS PLUS, INC. Line Item Account**

4121829 04/12/2018

Inv 18-894

<u>Line Item Date</u>	<u>Line Item Description</u>	<u>Line Item Account</u>	
03/01/2018	HOTSTART ENGINE BLOCK HEATER	02-61-72000	381.11

Inv 18-894 Total 381.11

4121829 Total: 381.11

**603480 - POWER SYSTEMS PLUS, INC. Total:** 381.11

**5976 - PRUDENTIAL OVERALL SUPPLY Line Item Account**

4121830 04/12/2018

Inv 130800868

<u>Line Item Date</u>	<u>Line Item Description</u>	<u>Line Item Account</u>	
01/16/2018	MATS & MISC	03-41-63401	160.86
01/16/2018	MONTHLY UNIFORMS	03-41-56511	140.28

Inv 130800868 Total 301.14

Inv 130800869

<u>Line Item Date</u>	<u>Line Item Description</u>	<u>Line Item Account</u>	
01/16/2018	MONTHLY UNIFORMS	03-41-56511	99.80

Inv 130800869 Total 99.80

Inv 130802369

<u>Line Item Date</u>	<u>Line Item Description</u>	<u>Line Item Account</u>	
01/23/2018	MATS & MISC	03-41-63401	7.30
01/23/2018	MONTHLY UNIFORMS	03-41-56511	134.30

Inv 130802369 Total 141.60

Inv 130802370

<u>Line Item Date</u>	<u>Line Item Description</u>	<u>Line Item Account</u>	
01/23/2018	MONTHLY UNIFORMS	03-41-56511	100.91

Inv 130802370 Total 100.91

Inv 130803885

<u>Line Item Date</u>	<u>Line Item Description</u>	<u>Line Item Account</u>	
01/30/2018	MATS & MISC	03-41-63401	160.86
01/30/2018	MONTHLY UNIFORMS	03-41-56511	135.94

Inv 130803885 Total 296.80

Inv	130803886				
	<u>Line Item Date</u>	<u>Line Item Description</u>	<u>Line Item Account</u>		
	01/30/2018	MONTHLY UNIFORMS	03-41-56511	100.91	
	Inv 130803886 Total				100.91
Inv	130805375				
	<u>Line Item Date</u>	<u>Line Item Description</u>	<u>Line Item Account</u>		
	02/06/2018	MONTHLY UNIFORMS	03-41-56511	129.09	
	02/06/2018	MATS & MISC	03-41-63401	7.30	
	Inv 130805375 Total				136.39
Inv	130805376				
	<u>Line Item Date</u>	<u>Line Item Description</u>	<u>Line Item Account</u>		
	02/06/2018	MONTHLY UNIFORMS	03-41-56511	100.91	
	Inv 130805376 Total				100.91
Inv	130806889				
	<u>Line Item Date</u>	<u>Line Item Description</u>	<u>Line Item Account</u>		
	02/27/2018	MATS & MISC	03-41-63401	160.86	
	02/27/2018	MONTHLY UNIFORMS	03-41-56511	136.70	
	Inv 130806889 Total				297.56
Inv	130806890				
	<u>Line Item Date</u>	<u>Line Item Description</u>	<u>Line Item Account</u>		
	02/13/2018	MONTHLY UNIFORMS	03-41-56511	100.91	
	Inv 130806890 Total				100.91
Inv	130808396				
	<u>Line Item Date</u>	<u>Line Item Description</u>	<u>Line Item Account</u>		
	02/20/2018	MATS & MISC	03-41-63401	7.30	
	02/20/2018	MONTHLY UNIFORMS	03-41-56511	146.96	
	Inv 130808396 Total				154.26
Inv	130808397				
	<u>Line Item Date</u>	<u>Line Item Description</u>	<u>Line Item Account</u>		
	02/20/2018	MONTHLY UNIFORMS	03-41-56511	100.91	
	Inv 130808397 Total				100.91
Inv	130809949				
	<u>Line Item Date</u>	<u>Line Item Description</u>	<u>Line Item Account</u>		
	02/27/2018	MATS & MISC	03-41-63401	160.86	
	02/27/2018	MONTHLY UNIFORMS	03-41-56511	136.70	
	Inv 130809949 Total				297.56

Inv	130809950				
	<u>Line Item Date</u>	<u>Line Item Description</u>	<u>Line Item Account</u>		
	02/27/2018	MONTHLY UNIFORMS	03-41-56511	100.91	
	Inv 130809950 Total				100.91
Inv	130811469				
	<u>Line Item Date</u>	<u>Line Item Description</u>	<u>Line Item Account</u>		
	03/06/2018	MATS & MISC	03-41-63401	7.30	
	03/06/2018	MONTHLY UNIFORMS	03-41-56511	129.85	
	Inv 130811469 Total				137.15
Inv	130811470				
	<u>Line Item Date</u>	<u>Line Item Description</u>	<u>Line Item Account</u>		
	03/06/2018	MONTHLY UNIFORMS	03-41-56511	100.91	
	Inv 130811470 Total				100.91
Inv	130813010				
	<u>Line Item Date</u>	<u>Line Item Description</u>	<u>Line Item Account</u>		
	03/13/2018	MONTHLY UNIFORMS	03-41-56511	163.33	
	03/13/2018	MATS & MISC	03-41-63401	160.86	
	Inv 130813010 Total				324.19
Inv	130813011				
	<u>Line Item Date</u>	<u>Line Item Description</u>	<u>Line Item Account</u>		
	03/13/2018	MONTHLY UNIFORMS	03-41-56511	100.91	
	Inv 130813011 Total				100.91
Inv	130814528				
	<u>Line Item Date</u>	<u>Line Item Description</u>	<u>Line Item Account</u>		
	03/20/2018	MATS & MISC	03-41-63401	7.30	
	03/20/2018	MONTHLY UNIFORMS	03-41-56511	130.07	
	Inv 130814528 Total				137.37
Inv	130814529				
	<u>Line Item Date</u>	<u>Line Item Description</u>	<u>Line Item Account</u>		
	03/20/2018	MONTHLY UNIFORMS	03-41-56511	100.91	
	Inv 130814529 Total				100.91
	4121830 Total:				3,232.01
	<b>5976 - PRUDENTIAL OVERALL SUPPLY Total:</b>				3,232.01
	<b>603175 - RODRIGUEZ, MANDY Line Item Account</b>				



4121831	04/12/2018				
Inv	022197				
	<u>Line Item Date</u>	<u>Line Item Description</u>	<u>Line Item Account</u>		
	03/07/2018	EVENT COORDINATOR - BRING YOUR KIDS TO WORK	03-42-56513	575.00	
	Inv 022197 Total				575.00
4121831 Total:					575.00
<b>603175 - RODRIGUEZ, MANDY Total:</b>					575.00
<b>6646 - SAN DIEGO COUNTY TREAS. - TAX Line Item Account</b>					
4121832	04/12/2018				
Inv	1528992				
	<u>Line Item Date</u>	<u>Line Item Description</u>	<u>Line Item Account</u>		
	03/07/2018	1ST AND 2ND INSTALLMENT FOR PARCEL 126-452-01-4	52-00-11158	51.07	
	Inv 1528992 Total				51.07
4121832 Total:					51.07
<b>6646 - SAN DIEGO COUNTY TREAS. - TAX Total:</b>					51.07
<b>603309 - SOUTHWEST AIRLINES Line Item Account</b>					
4121833	04/12/2018				
Inv	5261420982568-1				
	<u>Line Item Date</u>	<u>Line Item Description</u>	<u>Line Item Account</u>		
	03/05/2018	2018 ACWA SPRING CONFERENCE-FLIGHT FEE (MACK	03-20-75300	208.96	
	Inv 5261420982568-1 Total				208.96
Inv	5261420982568-2				
	<u>Line Item Date</u>	<u>Line Item Description</u>	<u>Line Item Account</u>		
	03/05/2018	2018 ACWA SPRING CONFERENCE-EARLY BIRD FEE (M	03-20-75300	15.00	
	Inv 5261420982568-2 Total				15.00
Inv	5261420982568-3				
	<u>Line Item Date</u>	<u>Line Item Description</u>	<u>Line Item Account</u>		
	03/05/2018	2018 ACWA SPRING CONFERENCE-EARLY BIRD FEE (M	03-20-75300	15.00	
	Inv 5261420982568-3 Total				15.00
Inv	5261429449539				
	<u>Line Item Date</u>	<u>Line Item Description</u>	<u>Line Item Account</u>		
	03/28/2018	2018 ACWA SPRING CONFERENCE-FLIGHT BOOKING I	03-20-75300	25.80	
	Inv 5261429449539 Total				25.80

Inv	5261429821469			
	<u>Line Item Date</u>	<u>Line Item Description</u>	<u>Line Item Account</u>	
	03/29/2018	2018 ACWA SPRING CONFERENCE-FLIGHT FEE (KENN	03-41-75300	212.96
	Inv 5261429821469 Total			212.96

4121833 Total: 477.72

**603309 - SOUTHWEST AIRLINES Total:** 477.72

**603406 - THE FRUIT GUYS Line Item Account**

4121834	04/12/2018			
Inv	5210195			
	<u>Line Item Date</u>	<u>Line Item Description</u>	<u>Line Item Account</u>	
	03/06/2018	EMPLOYEE SNACKS, HARVEST-SMALL	03-41-56513	38.25
	Inv 5210195 Total			38.25

Inv	5213102			
	<u>Line Item Date</u>	<u>Line Item Description</u>	<u>Line Item Account</u>	
	03/13/2018	EMPLOYEE SNACKS, HARVEST-SMALL	03-41-56513	76.50
	Inv 5213102 Total			76.50

Inv	5216178			
	<u>Line Item Date</u>	<u>Line Item Description</u>	<u>Line Item Account</u>	
	03/20/2018	EMPLOYEE SNACKS, HARVEST-SMALL	03-41-56513	38.25
	Inv 5216178 Total			38.25

Inv	5219159			
	<u>Line Item Date</u>	<u>Line Item Description</u>	<u>Line Item Account</u>	
	03/27/2018	EMPLOYEE SNACKS, HARVEST-SMALL	03-41-56513	76.50
	Inv 5219159 Total			76.50

4121834 Total: 229.50

**603406 - THE FRUIT GUYS Total:** 229.50

**7770 - U.S. POSTAL SERVICE Line Item Account**

4121835	04/12/2018			
Inv	1873262173			
	<u>Line Item Date</u>	<u>Line Item Description</u>	<u>Line Item Account</u>	
	03/07/2018	48-HOUR NOTICE PREPAY BALANCE RECHARGE	03-51-69000	300.00
	Inv 1873262173 Total			300.00

Inv	1875294555				
	<u>Line Item Date</u>	<u>Line Item Description</u>	<u>Line Item Account</u>		
	03/09/2018	48-HOUR NOTICE PREPAY BALANCE RECHARGE	03-51-69000	300.00	
	Inv 1875294555 Total				300.00
4121835 Total:				600.00	
<b>7770 - U.S. POSTAL SERVICE Total:</b>				600.00	
<b>603419 - UBER Line Item Account</b>					
4121836	04/12/2018				
Inv	AV3N0X5G				
	<u>Line Item Date</u>	<u>Line Item Description</u>	<u>Line Item Account</u>		
	03/20/2018	CONFERENCE UBER RIDE TIP- KHARP	03-42-75300	3.15	
	Inv AV3N0X5G Total				3.15
Inv	N8Z3C21G				
	<u>Line Item Date</u>	<u>Line Item Description</u>	<u>Line Item Account</u>		
	03/20/2018	CONFERENCE UBER RIDE- KHARP	03-42-75300	21.00	
	Inv N8Z3C21G Total				21.00
4121836 Total:				24.15	
<b>603419 - UBER Total:</b>				24.15	
<b>603479 - UNITED AIRLINES Line Item Account</b>					
4121837	04/12/2018				
Inv	7339135572902				
	<u>Line Item Date</u>	<u>Line Item Description</u>	<u>Line Item Account</u>		
	03/22/2018	AIRFARE CONFERENCE-AKHATTAB	03-41-75300	334.60	
	Inv 7339135572902 Total				334.60
4121837 Total:				334.60	
<b>603479 - UNITED AIRLINES Total:</b>				334.60	
<b>8155 - WESTERN WATER WORKS SUPPLY Line Item Account</b>					
4121838	04/12/2018				
Inv	481285-00				
	<u>Line Item Date</u>	<u>Line Item Description</u>	<u>Line Item Account</u>		
	02/19/2018	12" 3/16 THK X 40' LONG WB WSP CMLC	01-00-14610	3,609.72	
	02/19/2018	12X12 WIDE DIAPER	01-00-14610	53.61	
	Inv 481285-00 Total				3,663.33

Inv	483207-00			
	<u>Line Item Date</u>	<u>Line Item Description</u>	<u>Line Item Account</u>	
	03/20/2018	6X20X1/8 THICK ONE PIECE BUTT STRAP W/2" LIP TOG	01-00-14610	4,163.46
	03/20/2018	8X20X1/8 THICK ONE PIECE BUTT STRAP W/2" LIP TOG	01-00-14610	5,365.95
	Inv 483207-00 Total			9,529.41
Inv	483214-00			
	<u>Line Item Date</u>	<u>Line Item Description</u>	<u>Line Item Account</u>	
	02/20/2018	8-5/8 OD 10 GA STL PIPE WBXPE X40' LG CMLXCMC	01-34-72000	3,529.03
	Inv 483214-00 Total			3,529.03
Inv	483245-00			
	<u>Line Item Date</u>	<u>Line Item Description</u>	<u>Line Item Account</u>	
	03/02/2018	Meter box lid hook	01-00-14610	152.90
	03/02/2018	CMLC PIPE 8"	01-00-14610	2,646.77
	Inv 483245-00 Total			2,799.67
Inv	485543-00			
	<u>Line Item Date</u>	<u>Line Item Description</u>	<u>Line Item Account</u>	
	03/20/2018	6" 300# WELD FLANGE	01-00-14610	363.34
	Inv 485543-00 Total			363.34

4121838 Total: 19,884.78

**8155 - WESTERN WATER WORKS SUPPLY Total:** 19,884.78

**603450 - YOURMEMBERSHIP.COM Line Item Account**

4121839	04/12/2018			
Inv	1700289			
	<u>Line Item Date</u>	<u>Line Item Description</u>	<u>Line Item Account</u>	
	03/12/2018	JOB POSTING- ENVIRONMENTAL HEALTH AND SAFE]	03-42-75500	499.00
	Inv 1700289 Total			499.00

4121839 Total: 499.00

**603450 - YOURMEMBERSHIP.COM Total:** 499.00

**603437 - ZIPRECRUITER Line Item Account**

4121840	04/12/2018			
Inv				
	<u>Line Item Date</u>	<u>Line Item Description</u>	<u>Line Item Account</u>	
	02/28/2018	MONTHLY SUBSCRIPTION, 3 JOBS, STARTER PLAN	03-42-75500	249.00

	Inv Total			249.00
Inv	2942681			
	<u>Line Item Date</u>	<u>Line Item Description</u>	<u>Line Item Account</u>	
	03/12/2018	JOB POSTING-ENRIONMENTAL HEALTH AND SAFETY	03-42-75500	120.00
	Inv 2942681 Total			120.00
	4121840 Total:			369.00
	<b>603437 - ZIPRECRUITER Total:</b>			369.00
	<b>603451 - ZOHO CORP Line Item Account</b>			
	4121841	04/12/2018		
Inv	63500371			
	<u>Line Item Date</u>	<u>Line Item Description</u>	<u>Line Item Account</u>	
	03/08/2018	MONTHLY SUBSCRIPTION	01-35-72000	25.00
	Inv 63500371 Total			25.00
	4121841 Total:			25.00
	<b>603451 - ZOHO CORP Total:</b>			25.00
	<b>Total:</b>			<b>88,608.16</b>



**Director's Expenses  
FY 2017-2018**

Disbursement Date	Description	Miguel Gasca	Helene Brazier	Claude Hamilton	Michael Mack	William Stewart	Retiree
07/31/17	CAL PERS - HEALTH INS.						\$ 354.80
	WATER AGENCIES ASSOC OF S.D.						
	CSDA,SAN DIEGO CHAPTER						
	CONFERENCES (CSDA, ACWA, etc.)	\$ 600.00			\$ 600.00	\$ 600.00	
	TRAINING						
	COUNCIL OF WATER UTILITIES						
	DIRECTORS' PER DIEMS	\$ 150.00	\$ 300.00	\$ 300.00	\$ 700.00	\$ 300.00	
	TRAVEL EXPENSES	\$ 1,119.19			\$ 940.78	\$ 754.99	
	MILEAGE EXPENSE			\$ 23.54		\$ 577.82	
	<b>REIMBURSEMENT FROM DIRECTORS</b>						\$ (354.80)
	Monthly Totals	\$ 1,869.19	\$ 300.00	\$ 323.54	\$ 2,240.78	\$ 2,232.81	\$ -
08/31/17	CAL PERS - HEALTH INS.						\$ 354.80
	WATER AGENCIES ASSOC OF S.D.						
	CSDA,SAN DIEGO CHAPTER		\$ 30.00		\$ 30.00		
	CONFERENCES (CSDA, ACWA, etc.)						
	TRAINING						
	COUNCIL OF WATER UTILITIES	\$ 25.00					
	DIRECTORS' PER DIEMS	\$ 150.00	\$ 150.00	\$ 150.00	\$ 300.00	\$ 300.00	
	TRAVEL EXPENSES						
	MILEAGE EXPENSE						
	<b>REIMBURSEMENT FROM DIRECTORS</b>						\$ (354.80)
	Monthly Totals	\$ 175.00	\$ 180.00	\$ 150.00	\$ 330.00	\$ 300.00	\$ -

**Director's Expenses  
FY 2017-2018**

Disbursement Date	Description	Miguel Gasca	Helene Brazier	Claude Hamilton	Michael Mack	William Stewart	Retiree
09/30/17	CAL PERS - HEALTH INS.						\$ 354.80
	WATER AGENCIES ASSOC OF S.D.						
	CSDA,SAN DIEGO CHAPTER						
	CONFERENCES (CSDA, ACWA, etc.)				\$ 580.00		
	TRAINING	\$ 45.00					
	COUNCIL OF WATER UTILITIES						
	DIRECTORS' PER DIEMS	\$ 300.00	\$ 300.00	\$ 300.00	\$ 450.00	\$ 450.00	
	TRAVEL EXPENSES				\$ 1,303.92		
	MILEAGE AND EXPENSES	\$ 21.40					
	<b>REIMBURSEMENT FROM DIRECTORS</b>						\$ (354.80)
	Monthly Totals	\$ 366.40	\$ 300.00	\$ 300.00	\$ 2,333.92	\$ 450.00	\$ -
10/31/17	CAL PERS - HEALTH INS.						\$ 354.80
	WATER AGENCIES ASSOC OF S.D.						
	CSDA,SAN DIEGO CHAPTER						
	CONFERENCES (CSDA, ACWA, etc.)						
	TRAINING						
	COUNCIL OF WATER UTILITIES						
	DIRECTORS' PER DIEMS	\$ 150.00	\$ 150.00	\$ 150.00	\$ 450.00	\$ 450.00	
	TRAVEL EXPENSES						
	MILEAGE AND EXPENSES						
	<b>REIMBURSEMENT FROM DIRECTORS</b>						\$ (354.80)
	Monthly Totals	\$ 150.00	\$ 150.00	\$ 150.00	\$ 450.00	\$ 450.00	\$ -



**Director's Expenses  
FY 2017-2018**

Disbursement Date	Description	Miguel Gasca	Helene Brazier	Claude Hamilton	Michael Mack	William Stewart	Retiree
11/30/17	CAL PERS - HEALTH INS.						\$ 354.80
	WATER AGENCIES ASSOC OF S.D.						
	CSDA,SAN DIEGO CHAPTER	\$ 30.00	\$ 30.00	\$ 30.00	\$ 30.00		
	CONFERENCES (CSDA, ACWA, etc.)	\$ 699.00			\$ 699.00	\$ 699.00	
	TRAINING						
	COUNCIL OF WATER UTILITIES						
	DIRECTORS' PER DIEMS	\$ 300.00			\$ 300.00	\$ 600.00	
	TRAVEL EXPENSES	\$ 374.90			\$ 394.90	\$ 406.35	
	MILEAGE EXPENSE	\$ 79.18			\$ 137.39	\$ 80.36	
	<b>REIMBURSEMENT FROM DIRECTORS</b>						\$ (354.80)
	Monthly Totals	<u>\$ 1,483.08</u>	<u>\$ 30.00</u>	<u>\$ 30.00</u>	<u>\$ 1,561.29</u>	<u>\$ 1,785.71</u>	<u>\$ -</u>
12/31/17	CAL PERS - HEALTH INS.						\$ 354.80
	WATER AGENCIES ASSOC OF S.D.						
	CSDA,SAN DIEGO CHAPTER						
	CONFERENCES (CSDA, ACWA, etc.)						
	TRAINING						
	COUNCIL OF WATER UTILITIES						
	DIRECTORS' PER DIEMS	\$ 150.00	\$ 150.00	\$ 150.00	\$ 150.00	\$ 300.00	
	TRAVEL EXPENSES						
	MILEAGE EXPENSE						
	<b>REIMBURSEMENT FROM DIRECTORS</b>						\$ (354.80)
	Monthly Totals	<u>\$ 150.00</u>	<u>\$ 150.00</u>	<u>\$ 150.00</u>	<u>\$ 150.00</u>	<u>\$ 300.00</u>	<u>\$ -</u>
	<b>REPORT TOTAL (2017):</b>	<b>\$ 4,193.67</b>	<b>\$ 1,110.00</b>	<b>\$ 1,103.54</b>	<b>\$ 7,065.99</b>	<b>\$ 5,518.52</b>	<b>\$ -</b>

**Director's Expenses  
FY 2017-2018**

Disbursement Date	Description	Miguel Gasca	Helene Brazier	Claude Hamilton	Michael Mack	William Stewart	Retiree
01/31/18	CAL PERS - HEALTH INS. WATER AGENCIES ASSOC OF S.D. CSDA,SAN DIEGO CHAPTER CONFERENCES (CSDA, ACWA, etc.) TRAINING						\$ 347.11
	COUNCIL OF WATER UTILITIES	\$ 40.00			\$ 40.00		
	DIRECTORS' PER DIEMS	\$ 300.00	\$ 300.00	\$ 300.00	\$ 300.00	\$ 300.00	
	TRAVEL EXPENSES						
	MILEAGE EXPENSE	\$ 32.70		\$ 23.98	\$ 39.24		
	<b>REIMBURSEMENT FROM DIRECTORS</b>						\$ (347.11)
	Monthly Totals	<u>\$ 372.70</u>	<u>\$ 300.00</u>	<u>\$ 323.98</u>	<u>\$ 379.24</u>	<u>\$ 300.00</u>	<u>\$ -</u>
02/28/18	CAL PERS - HEALTH INS. WATER AGENCIES ASSOC OF S.D. CSDA,SAN DIEGO CHAPTER CONFERENCES (CSDA, ACWA, etc.) TRAINING						\$ 347.11
	COUNCIL OF WATER UTILITIES	\$ 30.00	\$ 30.00	\$ 650.00	\$ 30.00	\$ 30.00	
	DIRECTORS' PER DIEMS	\$ 150.00	\$ 150.00	\$ 450.00	\$ 300.00	\$ 300.00	
	TRAVEL EXPENSES			\$ 631.74			
	MILEAGE EXPENSE	\$ 32.70		\$ 106.82	\$ 52.32		
	<b>REIMBURSEMENT FROM DIRECTORS</b>			\$ 300.00			\$ (347.11)
	Monthly Totals	<u>\$ 252.70</u>	<u>\$ 155.00</u>	<u>\$ 2,138.56</u>	<u>\$ 382.32</u>	<u>\$ 330.00</u>	<u>\$ -</u>

**Director's Expenses  
FY 2017-2018**

Disbursement Date	Description	Miguel Gasca	Helene Brazier	Claude Hamilton	Michael Mack	William Stewart	Retiree
03/31/18	CAL PERS - HEALTH INS.						\$ 347.47
	WATER AGENCIES ASSOC OF S.D.						
	CSDA,SAN DIEGO CHAPTER						
	CONFERENCES (CSDA, ACWA, etc.)						
	TRAINING						
	COUNCIL OF WATER UTILITIES	\$ 40.00					
	DIRECTORS' PER DIEMS	\$ 150.00	\$ 150.00	\$ 150.00	\$ 150.00	\$ 150.00	
	TRAVEL EXPENSES	\$ 57.77					
	MILEAGE EXPENSE						
	<b>REIMBURSEMENT FROM DIRECTORS</b>						\$ (347.47)
	Monthly Totals	\$ 247.77	\$ 150.00	\$ 150.00	\$ 150.00	\$ 150.00	\$ -
04/30/18	CAL PERS - HEALTH INS.						\$ 347.11
	WATER AGENCIES ASSOC OF S.D.						
	CSDA,SAN DIEGO CHAPTER						
	CONFERENCES (CSDA, ACWA, etc.)						
	TRAINING						
	COUNCIL OF WATER UTILITIES	\$ 45.00					
	DIRECTORS' PER DIEMS	\$ 150.00	\$ 150.00	\$ 150.00	\$ 150.00		
	TRAVEL EXPENSES	\$ 32.70					
	MILEAGE EXPENSE						
	<b>REIMBURSEMENT FROM DIRECTORS</b>						\$ (347.11)
	Monthly Totals	\$ 227.70	\$ 150.00	\$ 150.00	\$ 150.00	\$ -	\$ -



# Bank Reconciliation

## Board Audit



Check No.	Vendor/Employee	Transaction Description	Date	Amount
Fund: 01 WATER FUND				
Department: 00				
ACH	ACWA-JPIA	MONTHLY HEALTH AND VISION INSURANCE - APR 2018	03/15/2018	71,498.60
ACH	ASTRA INDUSTRIAL SERV.INC	3/8 CRD REPAIR KIT 9170002B	03/15/2018	6,640.81
ACH	ASTRA INDUSTRIAL SERV.INC	6" 150# FLG CLAVAL 90G-01	03/22/2018	8,141.62
ACH	HEALTH EQUITY	HSA Anthem/Kaiser - 2018 ER Contribution (CD)	03/15/2018	1,500.00
ACH	NATIONAL METER & AUTOMATION	M1000 4" 8-DIAL HR-E REGISTER CF	03/15/2018	829.68
ACH	NATIONAL METER & AUTOMATION	Badger M-35 3/4" x 9" NSF 61 Brz, Brz Bttm, HRE-8 Encoder w/Itro	03/21/2018	28,510.65
ACH	NATIONAL METER & AUTOMATION	ITRON 100W+ ERT	03/29/2018	51,551.91
ACH	SAN DIEGO COUNTY WATER AUTH	WIRE TRANSFER FOR WATER PURCHASES - JAN 2018	03/08/2018	1,424,428.14
ACH	UNION BANK (VISA)	RESTOCK-COFFEE, HOT COCOA, FACIAL TISSUE, CANE SUGAR	03/13/2018	273.25
ACH	CHARLES C. SNEED	REIMBURSE RETIRED EMPLOYEE HEALTH INS - MAR 2018	03/15/2018	363.00
54469	FERGUSON WATERWORKS #1083	3000# THRD COUP-RETURNED ITEMS	03/15/2018	80.81
54474	CHRIS HAND	EMPLOYEE ASSISTANCE PROGRAM - COMPUTER LOAN	03/15/2018	2,000.00
54499	D.R. HORTON LOS ANGELES HOLDING COMPANY	Refund Check	03/21/2018	32.98
54501	DOCS WATER	Refund Check	03/21/2018	1,138.42
54505	MARIA LOPEZ	INSPECTION DEPOSIT BALANCE REIMB-NEW SEWER SERVICE INSTALL, GIRD	03/21/2018	826.35
54507	RAMONA PAVING	Refund Check	03/21/2018	1,123.64
54508	RAMONA PAVING	Refund Check	03/21/2018	1,143.13
54511	INC. TC CONSTRUCTION CO	Refund Check	03/21/2018	1,848.10
54512	WEST LILAC FARMS 2	Refund Check	03/21/2018	1,911.17
54535	HERCULES INDUSTRIES, INC	SMALL MASTERLOCK #2975 7/8"	03/26/2018	527.99
54538	LINCOLN NATIONAL LIFE INSURANCE COMPANY	MONTHLY INSURANCE - MAR 2018	03/26/2018	8,038.62
54539	PRINCIPAL LIFE INSURANCE COMPANY	STD EMPLOYER FICA SSI- FEB 2018	03/26/2018	313.31
54550	CORE & MAIN LP	3" MM OCTAVE METERW/ ENCODER MODULE AND ITRONCONNECTOR 10' "	03/29/2018	8,150.21
54552	FERGUSON WATERWORKS #1083	3/4"x3/8" BRASS BUSHING	03/29/2018	1,007.47
			<b>Total for Department: 00</b>	<b>1,621,879.86</b>
Department: 31 PUMPING				
54542	SAN DIEGO GAS & ELECTRIC	MONTHLY GAS AND ELECTRIC SERVICE #1065 087 935 1	03/26/2018	37,109.20
54563	WALTERS WHOLESAL	CH E34SP51 LEGEND PLATE	03/29/2018	383.71
			<b>Total for Department: 31 PUMPING</b>	<b>37,492.91</b>
Department: 32 OPERATIONS				
ACH	AIRGAS USA, LLC	CYLINDER RENTAL-NITROGEN	03/21/2018	20.46
ACH	AIRGAS USA, LLC	CYLINDER RENTAL: HAZMAT FEE	03/29/2018	18.75
ACH	BABCOCK LABORATORIES, INC	MONTHLY WATER ANALYSIS	03/22/2018	410.00
ACH	BP BATTERY INC.	VISION AGM GROUP 24 DEEP CYCLE	03/29/2018	405.37
ACH	MISSION VALLEY SANITATION-SD	PORTA POTTY RENTAL FOR WEED ABATEMENT	03/15/2018	141.07
ACH	UNION BANK (VISA)	INTEREST CHARGE	03/13/2018	166.31

54467	FALLBROOK IRRIGATION SUPPLIES	CAP PVC SLIP 21/2	03/15/2018	4.99
54472	HACH	2687100 Test Kit Hypochlorite, High Range, 5-15%	03/15/2018	311.42
54475	HOME DEPOT	LOCKING PLIERS SET 2PC	03/15/2018	21.72
54509	SAN DIEGO GAS & ELECTRIC	MONTHLY ELECTRIC SERVICE #2879 803 104 0	03/21/2018	117.66
54516	BANNER DAY, INC	Huntley cut down tree and remove limbs hanging over Hydrant.	03/22/2018	3,600.00
54530	AMERICAN WATER WORKS ASSOC.	PURCHASE OF C206-17 FIELD WELDING OF STEEL WATER PIPE MANUAL	03/26/2018	73.50
54537	JERRY KRAFT	REIMB FOR SWRCB GRADE T3 CERTIFICATION RENEWAL FEE	03/26/2018	140.00
54542	SAN DIEGO GAS & ELECTRIC	MONTHLY GAS AND ELECTRIC SERVICE #1065 087 935 1	03/26/2018	707.40
54554	HACH	Feild service of two CL17 chlorine analyzers. 2-onsite calibrati	03/29/2018	2,314.00
54560	QUALITY FENCE COMPANY	Repair of chain link fence and barbed wire	03/29/2018	460.00

**Total for Department: 32 OPERATIONS 8,912.65**

Department: 33 VALVE MAINTENANCE

54471	GERARDO CANCINO	REIMB FOR D-3 TEST FEE	03/15/2018	165.00
54522	FALLBROOK AUTO PARTS	BEARING PACKER TOOL, RHINORAMP	03/22/2018	143.20
54558	PACIFIC TEK	Labor to replace sensor	03/29/2018	493.95

**Total for Department: 33 VALVE MAINTENANCE 802.15**

Department: 34 WATER DISTRIBUTION

ACH	AIRGAS USA, LLC	HELMET WLDG PSSV BLCK	03/15/2018	61.77
ACH	AIRGAS USA, LLC	CYLINDER RENTAL-HAZMAT FEE	03/21/2018	83.70
ACH	AIRGAS USA, LLC	CYLINDER RENTAL - SMALL HELIUM	03/22/2018	15.01
ACH	AIRGAS USA, LLC	OXYGEN INDUSTRIAL 80	03/29/2018	399.16
ACH	ART'S TRENCH PLATE & KRAIL SERVICE CO, INC.	(3) 6X10 TRENCH PLATE RENTALS	03/15/2018	497.00
ACH	ART'S TRENCH PLATE & KRAIL SERVICE CO, INC.	6X10 TRENCH PLATE RENTAL	03/22/2018	78.00
ACH	ART'S TRENCH PLATE & KRAIL SERVICE CO, INC.	EYEBOLT RENTAL	03/29/2018	420.00
ACH	DRAVES PIPELINE, INC	valve repair	03/22/2018	10,856.00
ACH	SCW CONTRACTING CORPORATION	12" water main repair on Grammer rd (emergency)	03/15/2018	51,741.63
ACH	TRAFFIC SAFETY SOLUTIONS, LLC	TRAFFIC CONTROL 1/27/18-RMWD	03/29/2018	2,147.50
ACH	UNDERGROUND SERVICE ALERT	RAI88 NEW TICKET CHARGES	03/15/2018	217.90
ACH	UNION BANK (VISA)	DRINKING WATER FOR EMPLOYEES	03/13/2018	19.34
ACH	UNION BANK (VISA)	OVERLIMIT FEE	03/13/2018	174.50
54465	RENE DEL RIO	REIMB FOR TUITION FEES FOR WATERWORKS DISTRIBUTION CLASS	03/15/2018	161.00
54490	SOUTHLAND PAVING, INC.	EMERGENCY WATER MAIN REPAIR & PATCHING-GOPHER CANYON/TWIN OAKS	03/15/2018	16,566.85
54495	RICARDO ZARAGOZA	REIMB FOR TUITION FEES FOR WATER TREATMENT PLANT OPERATIONS	03/15/2018	162.53
54497	CECILIA'S SAFETY SERVICE	RECHE ROAD, RABBIT HILL TRAFFIC CONTROL - 1/3/18	03/21/2018	1,705.00
54559	PERRAULT CORPORATION	1" MINUS, TICKET-24878, 24876, 24874, 24870, 24867 & ENV FEE	03/29/2018	294.38

**Total for Department: 34 WATER DISTRIBUTION 85,601.27**

Department: 35 METER SERVICES

ACH	TEMECULA VALLEY BACKFLOW, INC.	ANNUAL BACKFLOW PREVENTION DEVICE TESTING/REPAIR SERVICES	03/15/2018	45,826.00
54475	HOME DEPOT	10PK GRIND	03/15/2018	21.52
54476	ITRON, INC	MSE-0122-002 Antenna Whip	03/15/2018	25,197.85
54483	NORTHERN TOOL & EQUIPMENT	Portable Generator	03/15/2018	1,003.81
54484	SEAN OLSON	RMWD Magnets 6"x20" Royal Blue Vinyl On White	03/15/2018	370.66
54556	KNOCKOUT PEST CONTROL& TERMITE, INC.	3 BEE REMOVALS	03/29/2018	225.00

**Total for Department: 35 METER SERVICES 72,644.84**

Department: 41 ADMINISTRATION/HR

54489	SECURED BUSINESS SUPPLIES	XEROX WC7855 WASTE CONTAINER	03/15/2018	298.00
-------	---------------------------	------------------------------	------------	--------

Fund: 02 SEWER FUND

Department: 00

ACH	CITY OF OCEANSIDE	SEWER TREATMENT - MARCH 2018	03/08/2018	67,336.59
54499	D.R. HORTON LOS ANGELES HOLDING COMPANY	Refund Check	03/21/2018	11.00
54500	DEVELOPMENT SOLUTION BONSALE	Refund Check	03/21/2018	4,269.51

Total for Department: 00 71,617.10

Department: 61 WASTEWATER

ACH	ATLAS PUMPING SERVICE	MONTHLY BIN RENTAL	03/15/2018	210.00
ACH	BABCOCK LABORATORIES, INC	MONTHLY WATER ANALYSIS	03/26/2018	105.00
ACH	HAAKER EQUIPMENT CO.	Manhole equipment	03/15/2018	462.93
ACH	HADRONEX, INC.	Active Site Management One year ( See Attachments)	03/15/2018	19,997.00
ACH	MCMaster-CARR SUPPLY COMPANY	Pressure gauges 0"-200" inches of water	03/22/2018	398.23
ACH	MUNICIPAL MAINTENANCE EQUIPMENT	8" Gaskets with holes	03/22/2018	273.04
ACH	O'REILLY AUTO PARTS	HEATER HOSE	03/22/2018	108.74
ACH	UNION BANK (VISA)	ESCONDIDO ASPHALT - WO 130168	03/13/2018	157.75
54459	AMERIGAS - TEMECULA	PROPANE GAS	03/15/2018	245.67
54466	ENVIRONMENTAL WATER SOLUTIONS	Air release valve right side	03/15/2018	1,919.26
54475	HOME DEPOT	6V BATTERY, MASON BRUSH, 123 LITHIUM BATTERY-2PK	03/15/2018	170.94
54477	JOE'S HARDWARE	ADAPTER GARDEN HOSE	03/15/2018	11.65
54486	RHO MONSERATE C.C.H.A.	ELECTRIC CHARGE	03/15/2018	389.06
54487	RYAN HERCO PRODUCTS CORP	Echotouch control 2 wire	03/15/2018	787.75
54493	WATER QUALITY SPECIALISTS	MONTHLY OPERATIONS - FEB 2018	03/15/2018	1,950.00
54498	POLLUTION CONTROL DISTRICT COUNTY OF SAN DIEGO, AIR	SITE PROCESSING/HANDLING FEE	03/21/2018	2,141.40
54520	CWEA	ANNUAL MEMBERSHIP RENEWAL FOR CHRIS HAND ID# 0000443381	03/22/2018	180.00
54542	SAN DIEGO GAS & ELECTRIC	MONTHLY GAS AND ELECTRIC SERVICE #8617 979 145 9	03/26/2018	7,097.68
54561	RYAN HERCO PRODUCTS CORP	PO# 30240-ECHOTOUCH CONTROL 2 WIRE	03/29/2018	785.00
54565	XYLEM INC	Part # 94 21 11 Remove and replace pump cables 3 -30' sections o	03/29/2018	6,606.89

Total for Department: 61 WASTEWATER 43,997.99

Total for Fund:02 SEWER FUND 115,615.09

Fund: 03 GENERAL FUND

Department: 00

ACH	ACWA-JPIA	MONTHLY HEALTH AND VISION INSURANCE - APR 2018	03/15/2018	-9,188.87
ACH	PUBLIC EMPLOYEES RETIREMENT	EMPLOYER CONTRIBUTION, UNFUNDED ACCRUED LIABILITY, PEPRA 26407	03/22/2018	28,507.82

Total for Department: 00 19,318.95

Department: 20 BOARD

54470	MIGUEL GASCA	COUNCIL OF WATER UTILITIES MILEAGE REIMB-GASCA	03/15/2018	32.70
54473	HAYDEN HAMILTON	CSDA SPECIAL DISTRICT LEADERSHIP ACADEMY TRAVEL REIMB-HAMILTON	03/15/2018	738.56
54479	MICHAEL MACK	CSDA QRTLY MEETING MILEAGE REIMB-MACK	03/15/2018	52.32
54519	COUNCIL OF WATER UTILITIES	CWU MEETING 3/20/18-MGASCA	03/22/2018	40.00

Total for Department: 20 BOARD 863.58

Department: 36 GARAGE

ACH	BP BATTERY INC.	DEKA GROUP 48 GM BATTERY AND BATTERY TAX	03/22/2018	740.30
-----	-----------------	------------------------------------------	------------	--------

ACH	FLYERS ENERGY LLC	ORDER 1408483-18, CARB REG 10% ETH 400 UNITS/DSL 300 UNITS	03/15/2018	8,630.95
ACH	FLYERS ENERGY LLC	ORDER 1423713-18, CARB REG 10% ETH 280 UNITS/DSL 100 UNITS	03/29/2018	2,689.98
ACH	HAWTHORNE MACHINERY COMPANY	OIL HYDRO	03/29/2018	299.17
ACH	O'REILLY AUTO PARTS	ITEM RETURNED: CERAMIC PAD	03/15/2018	264.33
ACH	O'REILLY AUTO PARTS	#72-OIL & AIR FILTER,#138-AIR & OIL FILTER, #60,105,61-AIR FILTE	03/22/2018	415.20
ACH	PARKHOUSE TIRE, INC.	LT245/75R16 E FST T/F AT2 BLK & OWL, RECYCLING FEE	03/15/2018	2,098.00
54458	RUSH TRUCK CENTERS OF CALIFORNIA, INC	Purchase & [nstall 4 Corner ECCO S Strobes 4 ECCO LED W/Lights	03/14/2018	94,961.96
54462	BRIDGESTONE HOSEPOWER, LLC	(See Attachment 82018074-00) Mobile Trip Charge	03/15/2018	313.99
54478	KONECRANES, INC.	COMPLETED QUARTERLY INSPECTION 3 MOBILE CRANES, FEB 2018	03/15/2018	945.00
54492	TRANSWEST SAN DIEGO, INC.	Pro Vision Model T-205A With VLI Series Night Vision Camera 5" M	03/15/2018	2,611.10
54498	POLLUTION CONTROL DISTRICT COUNTY OF SAN DIEGO, AIR	EMERGENCY YARD GENERATOR	03/21/2018	1,180.60
54503	HEAVY VEHICLE ELECTRONIC LICENSE PLATE	MONTHLY SERVICE - FEB	03/21/2018	17.65
54517	COMMUNICATIONS SERVICES	Speaker Switch	03/22/2018	853.71
54521	DION INTERNATIONAL	TRNSDUCR, EXHAUST	03/22/2018	411.56
54522	FALLBROOK AUTO PARTS	STARTER SWITCH	03/22/2018	308.53
54528	TRANSWEST SAN DIEGO, INC.	BODY LABOR (SEE ATTACHMENT)	03/22/2018	11,277.59
54534	HARRISON'S EQUIPMENT	E105379 Unloader Valve Assembly Complete ( See Attached Estim	03/26/2018	197.24

**Total for Department: 36 GARAGE 128,216.86**

Department: 41 ADMINISTRATION/HR

ACH	ACCELA, INC. #774375	WEB PAYMENTS WITH ONLINE-BILLS.COM	03/15/2018	5,000.00
ACH	HEALTH EQUITY	MONTHLY ADMINISTRATION FEES - FEB 2018	03/01/2018	306.05
ACH	IMAGE SOURCE	MONTHLY COPY COUNT	03/21/2018	255.22
ACH	IMAGE SOURCE	MONTHLY COPY COUNT	03/26/2018	297.83
ACH	INFOR PUBLIC SECTOR, INC.	INFOR CLOUSUITE SUBSCRIPTION SOFTWARE	03/22/2018	65,000.00
ACH	PUBLIC EMPLOYEES RETIREMENT	CALPERS REPLACEMENT FUND: ANNA CHRISTENSEN	03/15/2018	347.11
ACH	PUBLIC EMPLOYEES RETIREMENT	ASSESSED INTEREST ON UNPAID BALANCES	03/22/2018	0.36
ACH	RAFTELIS FINANCIAL CONSULTANTS	PROFESSIONAL SERVICES FROM 2/1/18-2/28/18, WATER & WW RATE STUDY	03/15/2018	410.00
ACH	REM MECHANICAL, INC	PERFORMED PREVENTATIVE MAINTENANCE, CHANGED FILTERS	03/22/2018	434.00
ACH	REM MECHANICAL, INC	CHECK THERMOSTAT AND GAS SMELL	03/26/2018	180.00
ACH	SOUTHWEST ANSWERING SERVICE, INC.	MONTHLY ANSWERING SERVICE	03/15/2018	1,301.55
ACH	STREAMLINE	MONTHLY WEB MANAGEMENT FEE	03/21/2018	300.00
ACH	STREAMLINE	MONTHLY WEB MANAGEMENT FEE	03/26/2018	300.00
ACH	STREAMLINE	MONTHLY WEB MANAGEMENT	03/29/2018	300.00
ACH	UNION BANK (VISA)	(5) EMPLOYEE MEALS - AFTER HOURS	03/13/2018	91.14
ACH	UNION BANK (VISA)	(6) EMPLOYEE LUNCHES - WELCOME NEW HIRE	03/13/2018	321.66
ACH	UNION BANK (VISA)	DISTRICT EVENT - LUNCH	03/13/2018	251.95
ACH	UNION BANK (VISA)	GO TO MY PC MONTHLY CHARGE	03/13/2018	156.60
ACH	XEROX CORP.	MONTHLY LEASE	03/15/2018	1,358.03
ACH	DAWN WASHBURN	BOARD SECRETARY LUNCH MEETING 3/6/18 REIMBURSEMENT	03/15/2018	51.42
54459	AMERIGAS - TEMECULA	PROPANE GAS	03/15/2018	1,525.34
54460	BONSALL PEST CONTROL	MONTHLY PEST CONTROL	03/15/2018	90.00
54464	COVERALL NORTH AMERICA, INC.	COMMERCIAL CLEANING SERVICES	03/15/2018	995.00
54468	FALLBROOK WASTE AND RECYCLING	MONTHLY REFUSE AND RECYCLE	03/15/2018	372.00
54475	HOME DEPOT	47X48 BLIND, EXTACTER, 60PK TWLS	03/15/2018	207.83
54480	MITEL LEASING	LEASE AGREEMENT	03/15/2018	764.30
54481	MODULAR BUILDING CONCEPTS, INC	RENTAL AGREEMENT	03/15/2018	4,871.26
54484	SEAN OLSON	18" X 24" Single sided aluminum with cast vinyl graphics. (2C)	03/15/2018	84.05
54485	PITNEY BOWES INC.	LEASE AGREEMENT	03/15/2018	686.82
54488	SAN DIEGO GAS & ELECTRIC	MONTHLY ELECTRIC SERVICE #4065 592 756 6	03/15/2018	3,203.32
54513	AT&T	MONTHLY PHONE SERVICE	03/22/2018	593.35
54514	AT&T LONG DISTANCE	MONTHLY PHONE SERVICE	03/22/2018	16.28
54518	COPY 2 COPY	BUSINESS CARDS - AHMED QTY.250	03/22/2018	90.46
54519	COUNCIL OF WATER UTILITIES	CWU MEETING 3/20/18-TKENNEDY	03/22/2018	40.00
54531	AT&T	MONTHLY PHONE SERVICE	03/26/2018	166.73



54532	AT&T	MONTHLY PHONE SERVICE	03/26/2018	592.16
54533	AT&T LONG DISTANCE	MONTHLY PHONE SERVICE	03/26/2018	16.32
54540	RANCHO LADERA ROAD ASSOCIATION	ANNUAL PREMIUM FOR RANCHOS LADERA ROAD LIABILITY INS POLICY	03/26/2018	110.00
54543	SHRED-IT USA LLC	MONTHLY SERVICE AGREEMENT	03/26/2018	73.37
54545	TIME WARNER CABLE	MONTHLY INTERNET CONNECTION - MAR 2018	03/26/2018	1,250.00
54546	XEROX FINANCIAL SERVICES	MONTHLY LEASE	03/26/2018	565.83
54548	BREAKERS ELECTRICAL SERVICE	Parts and Labor	03/29/2018	5,697.97
54555	INFOSEND, INC.	MONTHLY MAILING OF WATER BILLS AND NEWSLETTER	03/29/2018	437.61
54562	SOFTCHOICE CORPORATION	MS ENTERPRISE AGREEMENT SLG - O365GOVE3 SHRDSVR ALNG SUBSVL MVL	03/29/2018	16,560.22

**Total for Department: 41 ADMINISTRATION/HR 115,673.14**

Department: 42 HUMAN RESOURCES

ACH	UNION BANK (VISA)	(2) EMPLOYEE DINNER - CONFERENCE	03/13/2018	345.21
ACH	UNION BANK (VISA)	EMPLOYEE ANNIVERSARY BREAKFAST	03/13/2018	171.75
54523	OCCUPATIONAL HEALTH CENTERS OF CA, A MEDICAL CORP	SERVICES PERFORMED AT CMC	03/22/2018	131.00

**Total for Department: 42 HUMAN RESOURCES 647.96**

Department: 43 SAFETY

ACH	BOOT WORLD, INC	SAFETY BOOTS - CDAUGHERTY	03/29/2018	193.93
54461	BOOT BARN INC	SAFETY BOOTS: ALOPEZ & STERRELL	03/15/2018	395.74
54482	NATIONAL SAFETY COMPLIANCE,INC	DOT CERTIFIED DRG TEST, ALCOHOL TEST, FUEL SURCHARGE	03/15/2018	194.24
54547	ASBURY ENVIRONMENTAL SERVICES	NON HAZ SOLIDS PER DRUM, PPE, TECH, TRANSPORTATION PER HOUR	03/29/2018	1,045.00
54557	OCCUPATIONAL HEALTH CENTERS OF CA, A MEDICAL CORP	SERVICES PERFORMED AT CMC	03/29/2018	131.00

**Total for Department: 43 SAFETY 1,959.91**

Department: 51 FINANCE

54555	INFOSEND, INC.	MONTHLY MAILING OF WATER BILLS AND NEWSLETTER	03/29/2018	1,829.88
54564	WHITE NELSON DIEHL EVANS LLP	PROFESSIONAL SERVICES RENDERED THRU 2/28/18, AUDIT	03/29/2018	2,000.00

**Total for Department: 51 FINANCE 3,829.88**

Department: 52 CUSTOMER SERVICE

54526	RINCON DEL DIABLO MWD	CALENDARS, FORMS AND HANDLING FEE	03/22/2018	860.07
54541	RT LAWRENCE CORPORATION	LOCKBOX PROCESSING FEES FOR - FEB 2018	03/26/2018	714.31
54555	INFOSEND, INC.	MONTHLY MAILING OF WATER BILLS AND NEWSLETTER	03/29/2018	650.18

**Total for Department: 52 CUSTOMER SERVICE 2,224.56**

Department: 91 ENGINEERING

54494	WILLDAN FINANCIAL SERVICES	WATER & WASTEWATER ASSET COST AND CAPACITY FEE STUDY	03/15/2018	5,197.76
54506	OSTARI INC.	ONSITE COMPUTER AND DATABASE SERVICES - JAN 2018	03/21/2018	10,800.00
54525	OSTARI INC.	ONSITE COMPUTER AND DATABASE SERVICES - FEB 2018	03/22/2018	10,800.00
54529	WRA, INC.	BIOLOGICAL RESOURCE ASSESSMENT SERVICES	03/22/2018	4,172.75
54551	FEDEX	DELIVERY SERVICE	03/29/2018	42.85

**Total for Department: 91 ENGINEERING 31,013.36**

**Total for Fund:03 GENERAL FUND 272,734.84**

Fund: 26 NEW WATER SOURCES FUND

Department: 00

ACH	DUDEK	BONSALL BASIN DESALTER STUDIES	03/21/2018	5,346.25
-----	-------	--------------------------------	------------	----------

**Total for Department: 00 5,346.25**

**Total for Fund:26 NEW WATER SOURCES FUND 5,346.25**

Fund: 52 SEWER CAPITAL REPLACEMENT

Department: 00

ACH	KENNEDY/JENKS CONSULTANTS INC	LIFT STATION 1 REPLACEMENT DESIGN SERVICES	03/15/2018	111,305.16
ACH	KENNEDY/JENKS CONSULTANTS INC	LIFT STATION 1 REPLACEMENT DESIGN SERVICES	03/21/2018	22,246.38

**Total for Department: 00 133,551.54**

**Total for Fund:52 SEWER CAPITAL REPLACEMENT 133,551.54**

Fund: 60 WTR CAP EXPANSION/REPLACEMENT

Department: 00

54491	SPARLING INSTRUMENTS, LLC	Sparling Grounding Rings Part #AC615-24-1	03/15/2018	8,687.50
54496	CASS CONSTRUCTION, INC.	MOOSA CREST WATERLINE	03/21/2018	23,281.65
54502	HDR ENGINEERING, INC.	CONDITION ASSESSMENT OF WATER FACILITIES	03/21/2018	8,930.00
54504	INFRASTRUCTURE ENGINEERING	AS-NEEDED GENERAL ENGINEERING SERVICES	03/21/2018	2,050.00
54510	SCST, INC.	SPECIAL INSPECTION & MATERIAL TETING SERVICES FOR MOOSA CREST WA	03/21/2018	380.00
54515	BALTIC NETWORKS USA	PBE-5AC-300-ISO US 5-PAK	03/22/2018	1,088.91
54524	ONESOURCE DISTRIBUTORS, LLC	Miniature Circuit Breaker , 1 - pole 5 A ( see attachment )	03/22/2018	975.72
54527	TALLEY COMMUNICATIONS	HANGER KIT FOR 1/2" OR 3/8"	03/22/2018	254.45
54536	INFRASTRUCTURE ENGINEERING	R.A. WEESE FILTRATION PLANT INTERCONNECT PROJECT	03/26/2018	27,615.75
54544	SPARLING INSTRUMENTS, LLC	20" Sparling Magnetic Flow Meter Tigennag Series EP FM656	03/26/2018	7,294.65
54553	FREEDOM AUTOMATION, INC.	SCADA RTU system upgrade - Turner Tank integration	03/29/2018	42,495.00

**Total for Department: 00 123,053.63**

**Total for Fund:60 WTR CAP EXPANSION/REPLACEMENT 123,053.63**

**Grand Total 2,477,933.03**

# Comparative Water Sales YTD from Prior Years

## FISCAL YEAR 2017-2018

Quantity of Meters	User Code	JUL	AUG	SEP	OCT	NOV	DEC	JAN	FEB	MAR	APR	MAY	JUN	Acre Feet
591	AD	33,368	29,810	36,240	31,341	32,604	31,023	27,275	20,008	17,733				596
403	AG	143,947	131,374	145,023	120,650	125,864	102,753	92,501	61,270	63,137				2,265
5	C	-	-	-	-	-	-	-	-					-
231	CM	33,760	42,525	33,852	26,225	24,198	16,798	18,566	48,438	19,156				605
30	CN	2,468	3,986	8,073	10,498	18,605	5,633	3,526	2,577	2,103				132
24	IS	2,320	2,440	2,793	2,488	2,335	1,700	1,339	1,038	695				39
88	MF	11,472	10,002	13,072	10,304	11,489	11,350	9,566	8,403	8,262				216
326	SC	179,822	156,120	202,103	148,336	176,307	145,994	119,086	84,941	75,753				2,958
1034	SD	246,972	223,157	271,457	221,749	243,725	210,020	185,162	112,432	111,709				4,193
5122	SF	175,041	165,722	194,945	155,283	162,716	146,128	120,558	96,758	89,344				2,999
7854	Total	829,170	765,136	907,558	726,874	797,843	671,399	577,579	435,865	387,892	-	-	-	14,002

## FISCAL YEAR 2016-2017

Quantity of Meters	User Code	JUL	AUG	SEP	OCT	NOV	DEC	JAN	FEB	MAR	APR	MAY	JUN	Acre Feet
591	AD	36,216	34,134	39,119	28,217	22,903	24,494	7934	5036	5338				467
403	AG	156,957	152,359	172,040	132,882	104,544	96,050	31370	16829	20790				2,029
5	C	-	-	-	-	-	-	0	0	0				-
231	CM	47,830	45,043	43,040	26,707	20,970	21,140	5876	4333	4912				505
30	CN	4,900	4,950	7,309	11,456	7,427	904		63	924				87
24	IS	3,806	3,701	3,980	3,061	2,446	1,653	1408	594	700				49
88	MF	11,307	11,657	13,746	10,597	8,876	11,213	7139	7047	5954				201
326	SC	183,744	166,212	206,354	150,910	121,456	115,009	18861	6544	81497				2,412
1034	SD	279,246	253,718	298,226	222,243	181,674	171,322	39596.7	18148.3	21918.4				3,412
5122	SF	187,516	175,736	202,555	154,361	120,520	133,125	57385	42596	40254				2,558
7854	Total	911,522	847,510	986,369	740,434	590,816	574,910	169,570	101,190	182,287	-	-	-	11,719

## FISCAL YEAR 2015-2016

Quantity of Meters	User Code	JUL	AUG	SEP	OCT	NOV	DEC	JAN	FEB	MAR	APR	MAY	JUN	Acre Feet
601	AD	29,891	26,212	33,050	25,166	24,907	20,638	12532	10056	19640				464
404	AG	143,174	124,130	153,414	124,219	109,795	85,664	48608	35648	94227				2,109
6	C	4,342	3,764	4,773	2,948	1,761	665	428	0	0				43
221	CM	28,620	33,259	34,668	28,374	14,569	11,399	8431	8591	11738				412
37	CN	6,680	7,040	5,931	3,994	5,788	3,061	1002	1129	781				81
24	IS	2,773	2,779	2,486	3,073	3,299	2,641	828	796	2141				48
88	MF	11,351	10,279	10,887	9,952	9,664	8,600	8072	6667	7745				191
326	SC	162,756	144,892	188,145	132,002	133,998	109,284	46707	38985	108085				2,445
1038	SD	245,736	213,120	257,965	197,426	188,412	162,042	82599	57837	154618				3,581
5092	SF	148,573	143,404	162,621	135,030	120,706	96,899	69380	52522	95133				2,351
7837	Total	783,896	708,879	853,940	662,184	612,899	500,893	278,587	212,231	494,108	-	-	-	11,725

## FISCAL YEAR 2014-2015

Quantity of Meters	User Code	JUL	AUG	SEP	OCT	NOV	DEC	JAN	FEB	MAR	APR	MAY	JUN	Acre Feet
426	A	118,146	136,346	116,938	122,567	99,702	62,354	19943	44790	50073				1,770
341	C	102,461	111,946	90,197	95,608	76,060	51,612	29802	38013	48038				1,478
36	CN	3,175	3,510	3,579	2,898	1,119	372	1	0	22				34
5558	D	220,019	244,786	204,723	208,649	178,916	121,527	67259	80149	98723				3,271
96	MF	15,917	16,081	14,016	14,241	13,689	10,249	8659	8017	8763				252
323	SC	207,708	245,358	221,301	241,409	186,106	108,701	25015	79139	84982				3,213
1040	SD	284,083	332,533	282,418	297,792	260,513	165,578	46135	109682	137028				4,398
7820	Total	951,509	1,090,560	933,172	983,164	816,105	520,393	196,814	359,790	427,629	-	-	-	14,415

## Comparative Water Sales YTD from Prior Years

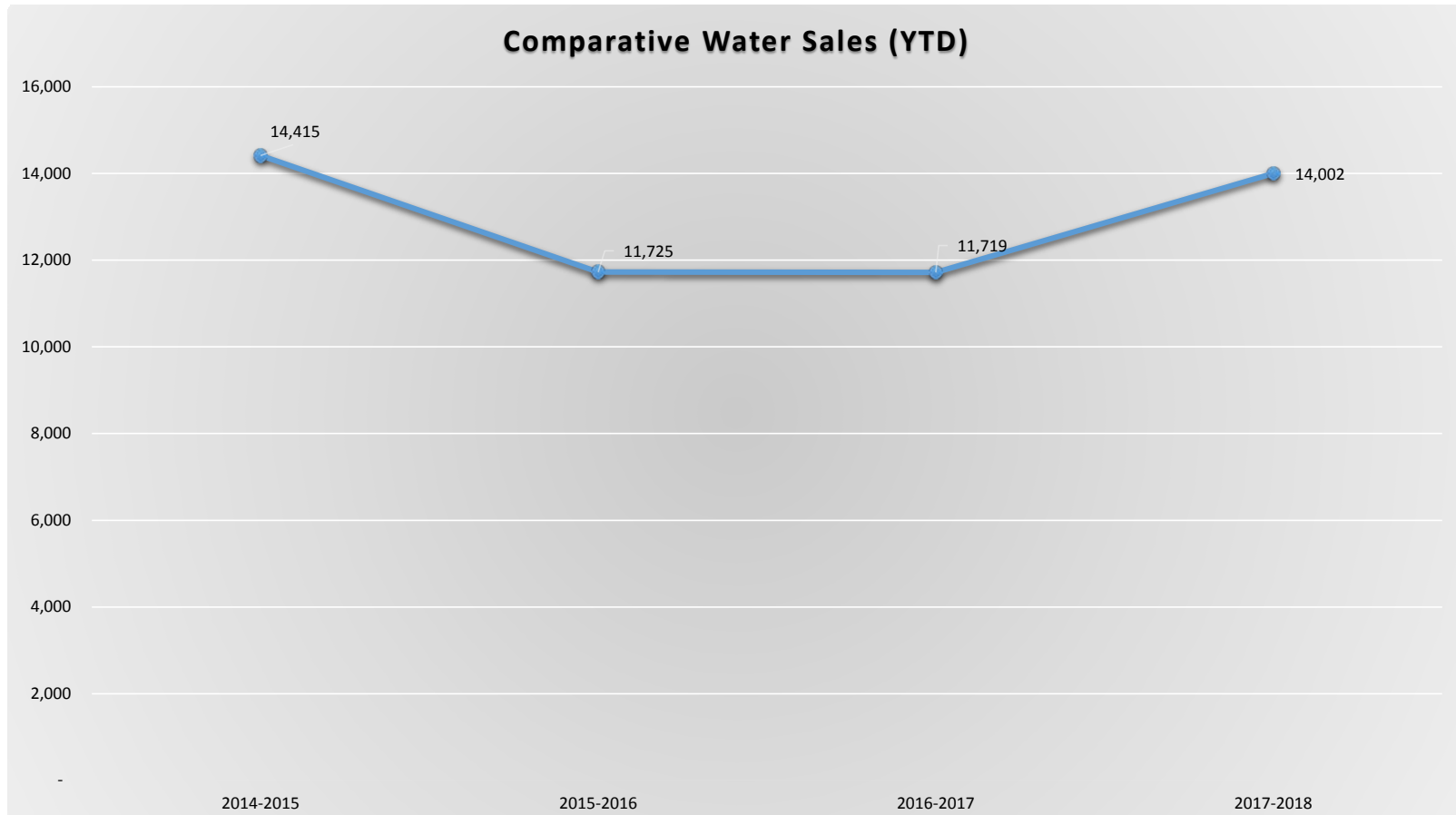

### USAGE BY CUSTOMER CLASS FY 17-18

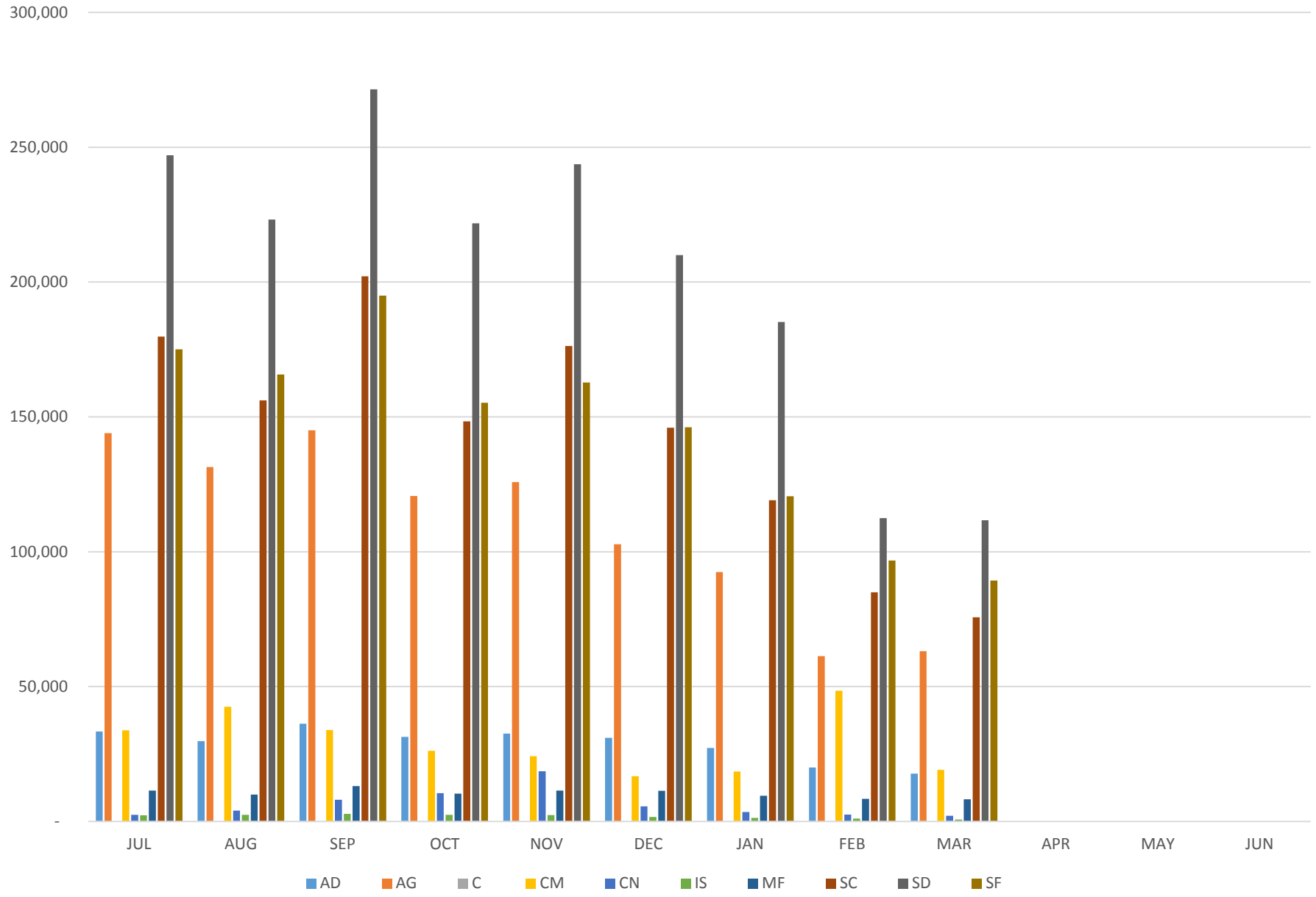





**SEWER EQUIVALENT DWELLING UNITS (EDUs) STATUS REPORT  
APRIL 2018**

<b>STATUS SUMMARY</b>	<b>EDUs</b>
Total Treatment Capacity Purchased from Oceanside	8,333.33
Less 5% Contractual Allowance	416.67
EDUs Set Aside by Board for Emergencies	60.00
EDUs Connected	4,603.33 *
EDUs Unconnected/Committed	656.40
<b>Total EDUs Available for Purchase:</b>	<b>2,596.94</b>

<b>DEVELOPMENTS WITH UNCONNECTED/COMMITTED EDUs</b>	<b>EDUs</b>	<b>CAPACITY FEES PAID</b>
Golf Green Estates (Dev. Solutions) - 102.46	76.66	\$ 1,413,252
Horse Creek Ridge - 754	254.50	\$ -
Passarelle (HRC Commercial) - 96.57	96.57	\$ -
Palomar College - 100	100.00	\$ -
Polo Club (Vista Valley Dev.) - 165 Lots	59.85	\$ 1,022,775 **
Pala Mesa Highlands (Beazer Homes) - 159.3	55.62	\$ 965,007 **
Others (5 or less)	13.20	\$ 204,156
<b>TOTAL UNCONNECTED:</b>	<b>656.40</b>	<b>\$ 3,605,190</b>

\*There is a delay between connections and new account activations.

\*\*Deferred Total Payment until Building Permits are Issued.

